



FIRST ORDER ALLPASS FILTERS EMPLOYING A SINGLE INVERTING SECOND GENERATION CURRENT CONVEYOR WITH AN APPLICATION EXAMPLE

Hasan SÖZEN¹, Selçuk KILINÇ²

¹Celal Bayar University, Department of Electrical and Electronics Engineering, Muradiye, Manisa, Turkey

²Dokuz Eylül University, Department of Electrical and Electronics Engineering, Buca, İzmir, Turkey
hasansozen76@gmail.com, selcuk.kilinc@deu.edu.tr

Abstract: A configuration containing a single inverting second generation current conveyor (ICCI) is presented. It realizes six different voltage mode first order allpass filters. As the application example, an oscillator circuit that uses one of these ICCI based filters is given. The theoretical analysis is verified by PSPICE simulations using a CMOS realization of ICCI. Experimental results are also included.

Keywords: Analog signal processing, first order allpass filter, inverting second generation current conveyor (ICCI), quadrature oscillator.

1. Introduction

Allpass filters are important parts of many electronic circuits and systems. They are generally used for introducing a frequency dependent delay while keeping the amplitude of the input signal constant over the desired frequency range [1, 2]. Other types of active circuits such as quadrature oscillators and high- Q bandpass filters are also realized by using allpass filters [1, 3]. Many first order allpass filter realizations using different active building blocks have been reported in the literature [2-4]. On the other hand, the inverting second generation current conveyor (ICCI) has been introduced as a new active element to give further possibilities to the analog designers [5]. Some ICCI based circuits are reported in the literature [5-10]. It has few applications to the realization of first order allpass filters [8-10]. In [8] four different voltage mode allpass filters have been presented. Chen, et al. has introduced an ICCI based configuration which provides both inverting and non-inverting first order allpass filtering functions simultaneously from the same topology [9]. First order allpass sections employing ICCIs have been used for the synthesis of a current mode universal filter in [10]. None of these filters contain a grounded capacitor. In this paper, we present an ICCI based configuration which realizes six different first order allpass filters. All realizations are canonic since they include only one capacitor as a dynamical element. One of the presented filters

employs a grounded capacitor. This filter has been used together with an ICCI based integrator, which also includes a grounded capacitor, to realize a quadrature oscillator. The functionality of the circuits has been shown by simulation and experimental results.

2. Circuit Description

The circuit symbol of ICCI element is shown in Figure 1. The port relations of the positive type ICCI are given by the following set of equations.

$$\begin{aligned} I_Y &= 0 \\ V_X &= -V_Y \\ I_Z &= I_X \end{aligned} \quad (1)$$

The configuration to be used in the synthesis of the first order allpass filters is given in Figure 2. Routine analysis of this configuration yields the following transfer function.

$$\frac{V_{out}}{V_{in}} = -\frac{Y_2(Y_1 + 2Y_3 + Y_4) + Y_1(Y_2 + 2Y_3 - Y_4 + Y_5 + 2Y_6)}{(Y_4 + 2Y_6 + Y_7)(Y_1 + 2Y_3 + Y_4) + Y_4(Y_2 + 2Y_3 - Y_4 + Y_5 + 2Y_6)} \quad (2)$$

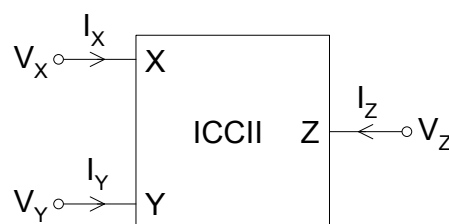

Figure1. Circuit symbol of ICCI

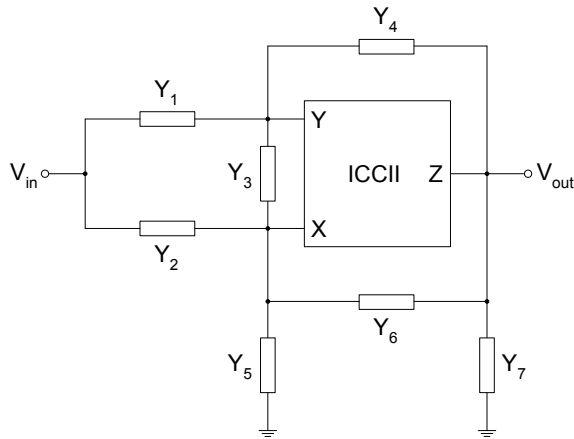

Figure 2. Filter configuration

Using various combinations for the admittances (Y's), six different first order allpass filters can be obtained from this configuration as given in Table 1. The first two filters (circuits 1 and 2) correspond to the ones presented in [8]. Transfer function for the circuits 1-to-4 is

$$T_1(s) = \frac{V_{out}}{V_{in}} = \frac{s - \frac{1}{RC}}{s + \frac{1}{RC}} \quad (3)$$

and their phase relation can be given by

$$\varphi_1(\omega) = 180^\circ - 2 \arctan(\omega RC) \quad (4)$$

The remaining two filters, i.e. circuits 5 and 6, have the following transfer function

$$T_2(s) = \frac{V_{out}}{V_{in}} = -\frac{s - \frac{1}{RC}}{s + \frac{1}{RC}} \quad (5)$$

and phase relation

$$\varphi_2(\omega) = -2 \arctan(\omega RC) \quad (6)$$

Therefore, both inverting and non-inverting types of first order allpass filters can be realized with the configuration of Figure 2. The only one that contains a grounded capacitor is the circuit 5 in Table 1.

If we also take into account the non-idealities of ICCII (i.e. $I_Y=0$, $V_X=-\beta V_Y$, $I_Z=\alpha I_Z$) for circuit 5, its transfer function becomes

$$T_3(s) = \frac{V_{out}}{V_{in}} = -\frac{s - \frac{1}{\alpha\beta RC}}{s + \frac{1}{\alpha\beta RC}} \quad (7)$$

As it is evident from Equation (7), the non-idealities have the same effect both on numerator and denominator, and hence they will not deteriorate the allpass filtering function of the circuit 5. Only the characteristic frequency and thus the phase relation will change as below

$$\varphi_3(\omega) = -2 \arctan(\omega \alpha\beta RC) \quad (8)$$

The values of resistor and capacitor can be modified as R/α and C/β in order to eliminate the effect of non-idealities completely.

Table 1. Admittance combinations for the realization of the first order allpass filters

Circuit No	Y_1	Y_2	Y_3	Y_4	Y_5	Y_6	Y_7
1	sC	1/R	0	∞	0	0	0
2	∞	0	0	sC	0	1/(2R)	0
3	∞	0	0	sC	1/R	0	1/R
4	∞	1/(2R)	0	sC	0	0	1/R
5	1/R	0	0	1/R	sC	0	0
6	2/R	0	sC/2	1/R	0	0	0

3. Quadrature Oscillator As The Application Example

It is a well-known fact that a sinusoidal quadrature oscillator can be realized using an allpass section and an integrator [11] as shown in Figure 3. Using this block diagram, ICCII based quadrature oscillator can be implemented. To this end, the presented first order allpass filter and an ICCII based integrator, which can be realized by the circuit of Figure 4, are used together with voltage buffers for cascade connection. For providing a sinusoidal oscillation, the loop gain of the circuit is set to unity at $s = j\omega$, i.e.

$$\left[\begin{array}{c} -\frac{s-1/(R_1C_1)}{s+1/(R_1C_1)} \\ -\frac{1}{sR_2C_2} \end{array} \right]_{s=j\omega} = 1 \tag{9}$$

From Equation (9) oscillation condition and frequency can be found respectively as

$$R_1C_1 = R_2C_2 \tag{10}$$

$$\omega_0 = \sqrt{\frac{1}{R_1C_1R_2C_2}} \tag{11}$$

For simplicity, if we choose $R_1 = R_2 = R$ and $C_1 = C_2 = C$, oscillation condition is satisfied and oscillation frequency becomes

$$\omega_0 = \frac{1}{RC} \tag{12}$$

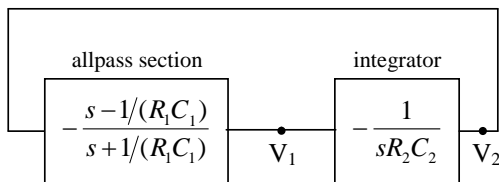

Figure 3. Block diagram for quadrature oscillator

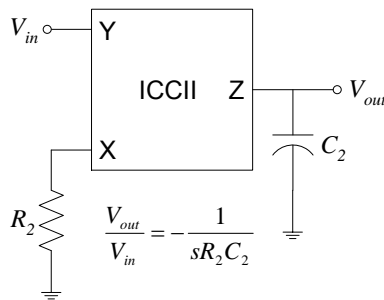

Figure 4. ICCII based integrator circuit

4. Simulation and Experimental Results

The first order allpass filter and the oscillator circuit have been simulated using PSPICE program. In the simulations, the CMOS realization of ICCII presented in [12] has been used together with 0.35µm CMOS process parameters. Supply voltages were taken as ±2.5V. Simulated magnitude and phase responses of the first order allpass filter are shown in Figure 5. We used $R=1k\Omega$ and $C=100pF$ as the passive element values. Simulation results give the natural frequency as 1.58MHz, which is very close to the theoretical one (1.59MHz). Transient analysis of the filter has also been done using PSPICE simulations with the same passive element values. For this purpose, a sinusoidal voltage of 2V peak-to-peak with a frequency of 1MHz has been applied to the input of the filter and the output voltage has been observed. Figure 6 shows the simulated input and output voltages in time domain. According to the simulation results, there is 183ns of phase difference between the signals, which corresponds to 65.9 degrees. The theoretical value for the phase difference at 1MHz calculated using Equation (6) is 64.3 degrees, which is close to the simulated one. The distortion analysis has also been done. The total harmonic distortion at the output of the filter is found as 0.3% using PSPICE. The simulated output waveforms of the quadrature oscillator are shown in Figure 7 where all resistor and capacitor values were taken as 1kΩ and 100pF, respectively. They oscillate at a frequency of 1.57MHz which is again near to the theoretical oscillation frequency (1.59MHz).

The circuits have also been tested experimentally. ICCII element has been implemented using Analog Devices' AD844 integrated circuit as shown in Figure 8. Supply voltages were taken as ±5V. Buffered output of the AD844 has been used for the cascade connection in the experimental setup of the quadrature oscillator. In the experiments, all resistor and capacitor values were taken as 1kΩ and 10nF, respectively. Figure 9 shows the input (1V peak, 50kHz) and output waveforms of the first order allpass filter. As it is expected, the output waveform has been shifted by -145.5 degrees (theoretically -144.7 degrees) while keeping the amplitude almost unchanged. Figure 10 shows the experimental waveforms of the quadrature oscillator. They oscillate at a frequency of 16.3kHz (theoretical one is 15.9kHz) with 90 degrees phase difference between them.

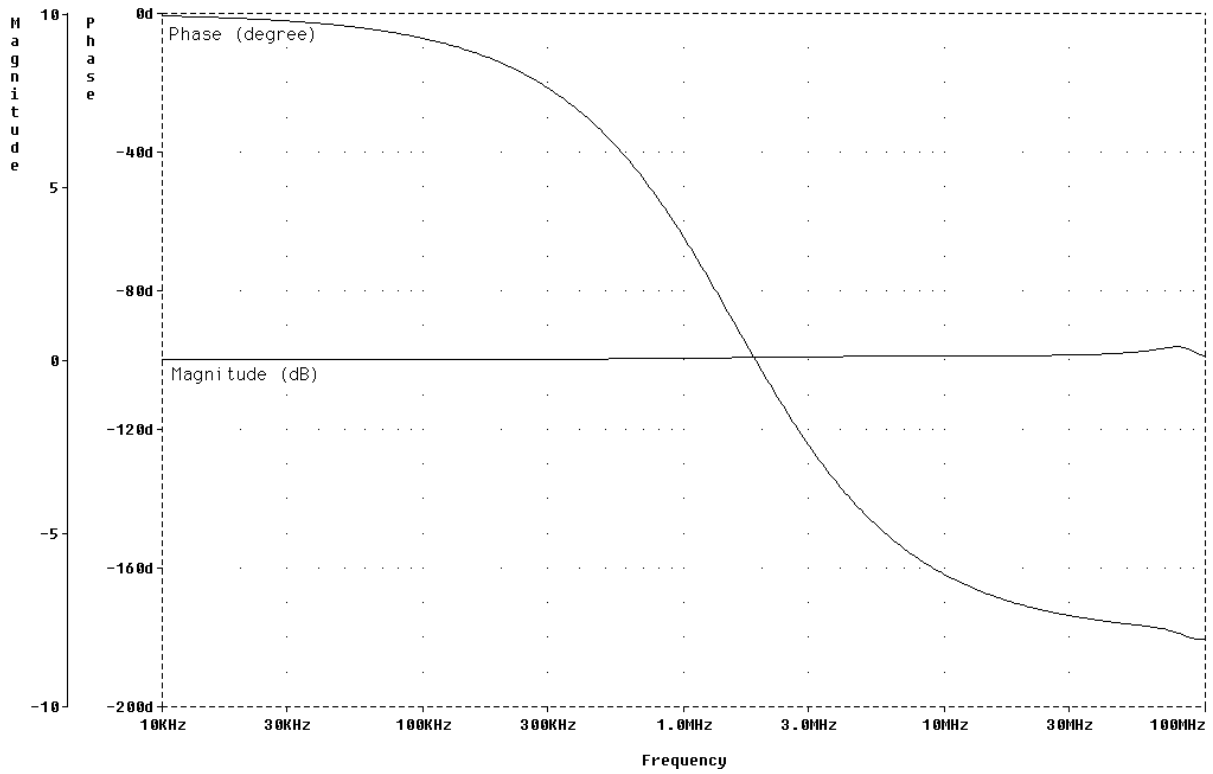

Figure 5. Simulated magnitude and phase responses of the first order allpass filter

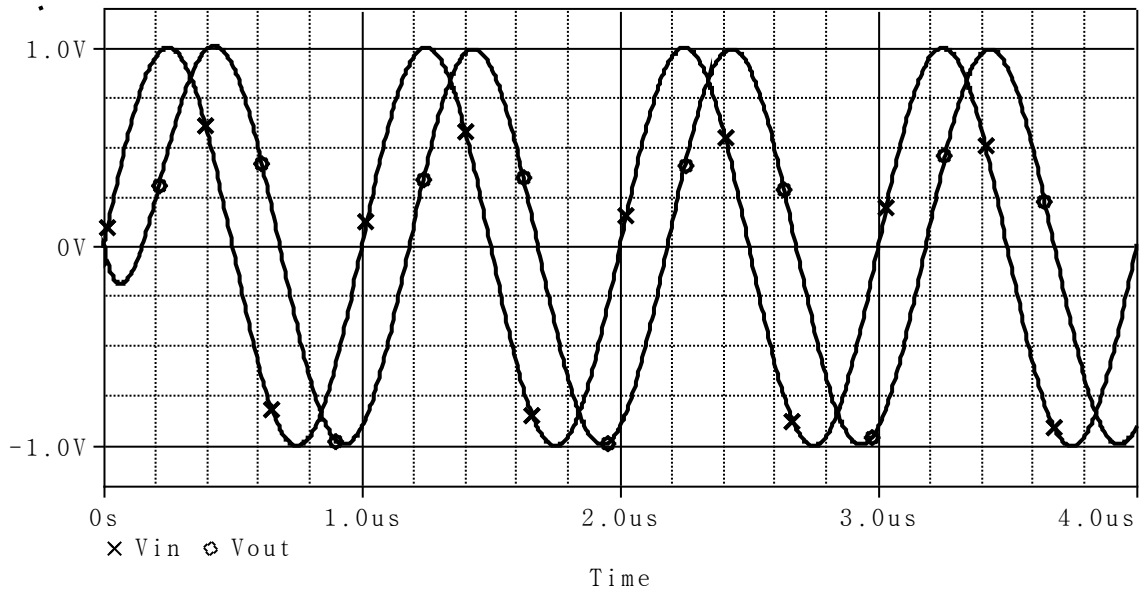

Figure 6. Transient response of the filter

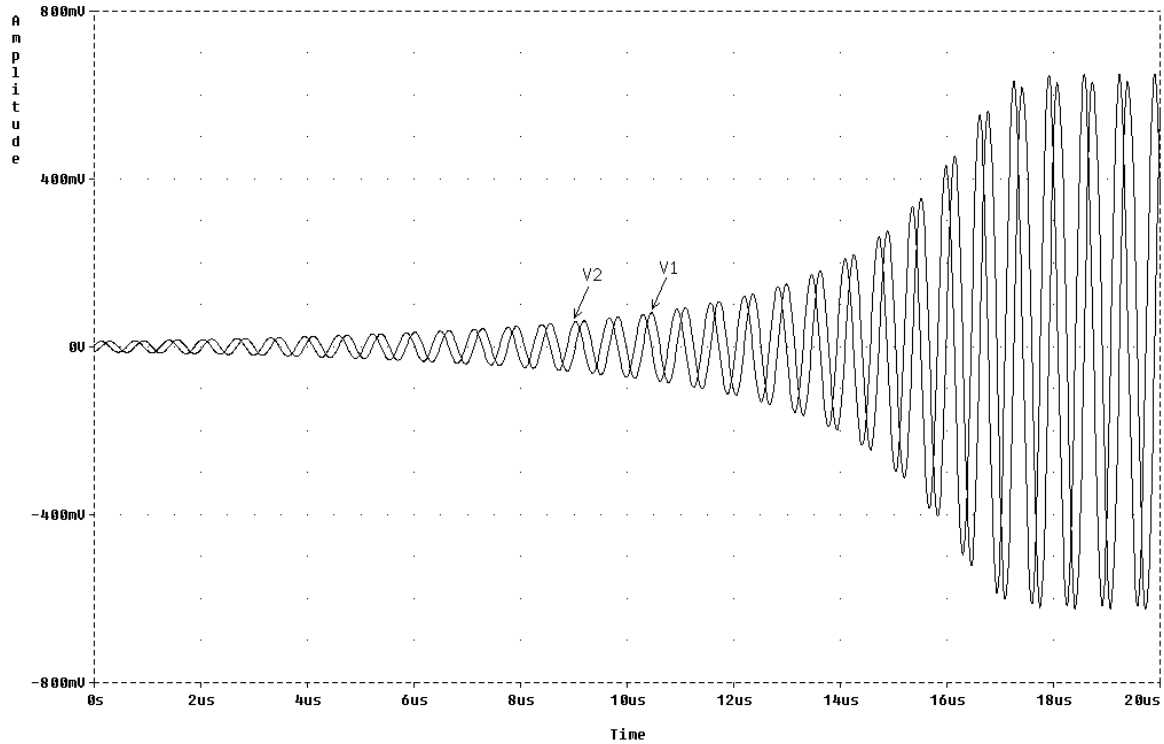

Figure 7. Simulated waveforms of the quadrature oscillator

5. Conclusions

An ICCII based configuration, which realizes six different first order allpass filtering functions, is presented. One of the filters is used together with an ICCII based integrator to form a quadrature oscillator as the application example of the presented filter. PSPICE simulation results verifying the predicted theory are included. The first order allpass filter and the quadrature oscillator circuits are also tested experimentally in the laboratory using the AD844 implementation of ICCII element.

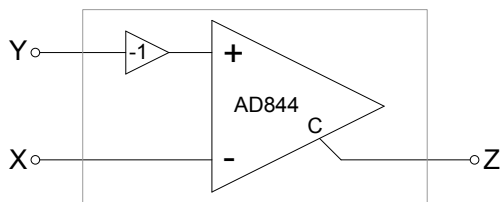

Figure 8. Implementation of ICCII

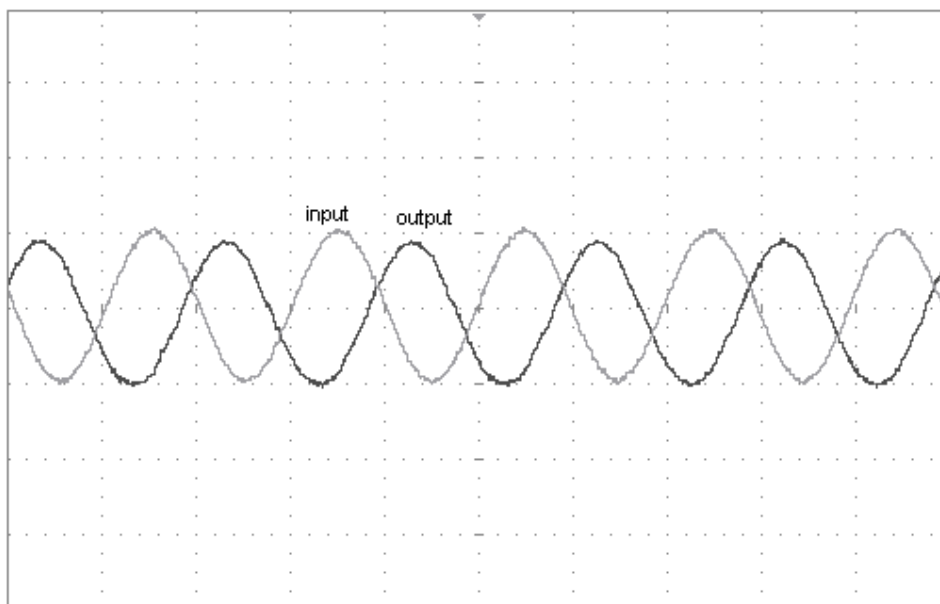

Figure 9. Experimental waveforms of the allpass filter (Volt/Div=1V, Time/Div=10µs)

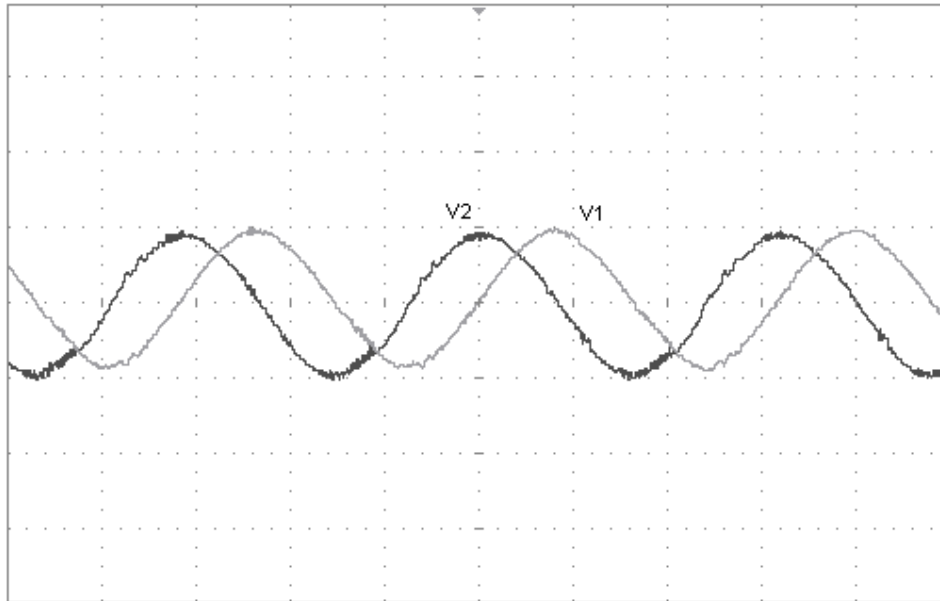

Figure 10. Experimental waveforms of the oscillator (Volt/Div=1V, Time/Div=20 μ s)

6. References

- [1] R. Schaumann, M. E. VanValkenburg, "Design of analog filters", Oxford University Press, New York, USA, 2001.
- [2] S. Öztayfun, S. Kılınç, A. Çelebi, U. Çam, "A new electronically tunable phase shifter employing current-controlled current conveyors", *International Journal of Electronics and Communications (AEÜ)*, vol. 62, pp. 228–231, 2008.
- [3] A. Toker, S. Özoğuz, O. Çiçekoğlu, C. Acar, "Current-mode all-pass filters using current differencing buffered amplifier and new high-Q bandpass filter configuration", *IEEE Transactions on Circuits and Systems-II*, vol. 47, pp. 949–954, 2000.
- [4] O. Cicekoglul, H. Kuntman, S. Berk, "All-pass filters using a single current conveyor", *International Journal of Electronics*, vol. 86, pp. 947–955, 1999.
- [5] I.A. Awad, A.M. Soliman, "Inverting second generation current conveyors: the missing building blocks, CMOS realizations and applications", *International Journal of Electronics*, vol. 86, pp. 413–432, 1999.
- [6] S. Minaei, E. Yuce, O. Cicekoglul, "ICCI-based voltage-mode filter with single input and six outputs employing grounded capacitors", *Circuits, Systems, and Signal Processing*, vol. 25, pp. 559–566, 2006.
- [7] A. M. Soliman, "The inverting second generation current conveyors as universal building blocks", *International Journal of Electronics and Communications (AEÜ)*, vol. 62, pp. 114–121, 2008.
- [8] M. A. Ibrahim, H. Kuntman, S. Ozcan, O. Suvak, O. Cicekoglul, "New first-order inverting-type second-generation current conveyor-based all-pass sections including canonical forms", *Electrical Engineering*, vol. 86, pp. 299–301, 2004.
- [9] H. -P. Chen, M. -T. Lin, W. -S. Yang, "Novel first-order non-inverting and inverting output all-pass filter at the same configuration using ICCII", *IEICE Transactions on Electronics*, vol. E89-C, pp. 865–867, 2006.
- [10] S. Özoğuz, A. Toker, O. Çiçekoğlu, "First-order allpass sections-based current-mode universal filter using ICCIIs", *Electronic Letters*, vol. 36, pp. 1443–1444, 2000.
- [11] I. Haritantis, "General method for designing RC harmonic oscillators", *International Journal of Electronics*, vol. 58, pp. 295–305, 1985.
- [12] M. A. Ibrahim, H. Kuntman, "A CMOS realization of inverting second generation current conveyor 'positive' (ICCI+)", in the *Proceedings of Nordic Signal Processing Symposium*, Norway, 2002.



Hasan SÖZEN received B.Sc. degree in Electrical and Electronics Engineering from Pamukkale University in 2009. He has also been working as a Research and Teaching Assistant in the Department of Electrical and Electronics Engineering, Celal Bayar University since 2011. His research interest includes analog circuit design.



Selçuk KILINÇ received B.Sc., M.Sc. and Ph.D. degrees from Dokuz Eylül University in 1999, 2002 and 2006 respectively, all in Electrical and Electronics Engineering. He has been with the Department of Electrical and Electronics Engineering, Dokuz Eylül University since September 1999 where he now works as an Assistant Professor. His research interest includes analog integrated circuit design.

