

International Journal of

**ADVANCES IN
ARTIFICIAL
INTELLIGENCE
RESEARCH**

A I R

Volume 1, Issue 2, 2021





Advances in Artificial Intelligence Research

<https://dergipark.org.tr/aaair>

Owner

Osman ÖZKARACA - Muğla Sıtkı Koçman University

Editor-in-Chief

Ali KEÇEBAŞ - Muğla Sıtkı Koçman University
Osman ÖZKARACA - Muğla Sıtkı Koçman University

Editors

Dr. Hüseyin ŞEKER	Staffordshire University, School of Computing and Digital Tech, England
Dr. Tuncay YİĞİT	Süleyman Demirel University, Computer Engineering Department, Turkey
Dr. Uğur Güvenç	Electric-Electronic Engineering, Düzce University, Düzce, Turkey
Dr. Jude HEMANTH	Karunya University, Electronics and Communication Engineering, India
Dr. Yusuf SÖNMEZ	Gazi University, Vocational College of Technical Sciences, Turkey
Dr. Ender ÖZCAN	Nottingham University, Computer Science and Operational Research, England
Dr. Hamdi Tolga KAHRAMAN	Karadeniz Technical University, Software Engineering, Turkey
Dr. Bogdan PATRUT	Alexandru Ioan Cuza University, Faculty of Computer Science, Romania
Dr. Ali Hakan IŞIK	Mehmet Akif Ersoy University, Computer Engineering, Turkey
Dr. İsmail Serkan ÜNCÜ	Isparta Applied Sciences University, Electrical-Electronics Engineering Turkey
Dr. Gürcan Çetin	Information Systems Engineering, Muğla Sıtkı Koçman University, Turkey
Dr. İsmail Yabanova	Mechatronics Engineering, Afyon Kocatepe University, Turkey

Date of Publication	August 2021
Language	English
Frequency	Published twice in a year
Graphic designer	Özden Işıқтаş

Correspondence Address	Muğla Sıtkı Koçman University, Faculty of Technology, Information Systems Engineering, 48000 Kötekli/MUĞLA
Phone	0 506 4887818 – 0252 211 5526
Correspondence Mail	osmanozkaraca@mu.edu.tr

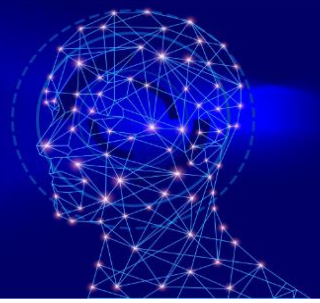

Table of Contents

Pages	Research Articles
43-51	ANALYSING THE EFFECTS OF CLASSROOM UTILISATION WITH A SELF-GENERATING MULTIMEME MEMETIC ALGORITHM FOR THE EXAM TIMETABLING PROBLEM Cevriye Altıntaş, Tuncay Yiğit
52 - 59	ENCRYPTION METHODS AND COMPARISON OF POPULAR CHAT APPLICATIONS Muhammed Burak Kılıç
60 - 66	EDUCATIONAL ASPECT OF HISTORY THEMED STRATEGY TYPE COMPUTER GAMES Muhammet Emin Varelci
67 - 72	META-HEURISTIC ALGORITHM-BASED OPTIMAL PID CONTROLLER DESIGN FOR POWER CONVERTERS Cihan Demircan, Onur Vahip Güler, Ali Keçebaş

Review Articles

73 - 79	A REVIEW ON DEEP LEARNING MODELS FOR SATELLITE IMAGERY Hasan Ersan Yağcı, Abdullah Atçılı, Şükrü Sezer
---------	--

Analysing the effects of classroom utilisation with a self-generating multimeme memetic algorithm for the exam timetabling problem

Cevriye Altıntaş^{1,*}, Tuncay Yiğit²

¹ Isparta University of Applied Sciences, Dept. of Computer Engineering, Isparta, Turkey
0000-0001-5928-3402

² Süleyman Demirel University, Dept. of Computer Engineering, Isparta, Turkey
0000-0001-7397-7224

Abstract

Universities have three main missions which are education, research and community service. The activities related to these missions gain vitality through the elements of “human” and “space.” The Human element consisting of academic staff and administrative staff working in universities represents the university's human capital. The buildings titled as faculty, vocational school, hospital, laboratory, research center on the other hand, constitute the elements of space. These spaces, housing the activities of academic and administrative staff, also represent the physical capital of universities. Universities not only need to be continue their education processes successfully, but they should also be manage to the use of resources in the most effective way. The classroom is the center of the school activities. Classroom management is very different from planning and evaluating other space needs. Without an effective classroom management, the heavy investment in the school system could produce loss rather than gain. It relates to the effective classroom planning, management techniques and classroom utilisation in determining accurately how many students the facilities will adequately support. Classroom capacity utilization is an economics concept which refers to the extent to which a higher education institutes or a nation actually uses its available classroom capacity. Therefore, the relationship between whether used and how classroom is being used is very important. Classroom utilisation rate is a percentage-based ratio based on an occupancy rate and frequency rate. The frequency rate evaluates how many times that classroom is used compared to its availability, and the occupancy rate evaluates how many users can actually use the space at one time the classroom is compared to its actual capacity. The main purpose of this study is to analysis the classroom utilisation effects on exam timetabling problem with a self-generating memetic algorithm. The results from the analysis show that classroom utilisation rates for exam timetabling problem should be addressed fully by top management. This study also offers that in order to improve the classroom utilisation rate, higher education institutes should think about the occupancy rate as it is the determining agent affecting the utilisation rate.

Keywords: *Classroom Management, Exam Timetabling, Memetic Algorithm.*

1. Introduction

The exam timetabling (ETP) is a multi-dimensional optimisation problem because it cannot be solved in polynomial time. Exam scheduling is one of the most critical administrative actions that occurs in all higher education institutions [1]. The aim in the ETP, time and the availability of classrooms is maximization of the overall process for a certain period of time constraints in a series. There are many researchers who have suggested models and methods for solving ETP problem. However, the problem of assigning a number of exams into a restricted number of classrooms and the classroom utilisation rate have not been widely analyzed in exam timetabling studies. The assignment of exams to periods and the assignment of exams to classrooms should not be considered separately from each other [2]. A large number of exams and the various classroom capacities with difference in exam periods make the assignment between classrooms and exams complex. As well, the capacity of classrooms may play a significant role in producing the solution to the ETP. As it has been already defined in many publications, constraints are usually divided into two categories. First, those constraints are designated hard constraints. All of them must be satisfied under any circumstances, and only a timetable without violations of hard constraints can be considered as feasible. Second, those constraints are represented soft constraints. Some or all of them are not essential but should be fulfilled as much as possible. But, it is desired that all of the soft constraints should have minimum values. Constraints, improving the quality of education, raising the performance of students and teaching staff, teaching staff are based on a desire to respond to administrative needs. We may not obtain optimal solution, even though the whole capacity of classrooms exceeds the entire student population to take all exams for a given period.

*Corresponding author

E-mail address: cevriyealtintas@isparta.edu.tr

According to these theories, using the precise actual total capacity of classrooms as an input to ETP may not produce an appropriate solution to the classroom-assignment problem [3]. Space inventory management process plays an important role in any institution of higher education and requires comprehensive planning to be done in systematic way [4]. Higher education institutes not only need to be accomplished in teaching, in doing research and in expanding participation but they should also be efficient in order to perform in a manner which makes the best manage their properties [5]. Classroom management is more than the evaluation of space needs. It relates to the classroom planning, management process and classroom utilisation in determining accurately how many students the facilities will adequately support. Efficient use of space is as valuable as its effective usage. The latest standards for space use and related work practices should be strike the balance between efficiency and effectiveness on the basis of evidence. Classroom utilisation rate is an indicator of whether and how classroom is being used [6]. The analysis of classroom utilisation rate was conducted with the following our goals:

- Determine the current classroom utilisation rate
- Evaluate potential reduction in the number of classrooms
- Share data and analysis with the stakeholders
- Develop strategies that encourage better use of the available resource base
- Provide added space to departments for research, offices, etc
- Help students avoid scheduling conflicts
- Improve space utilisation on campus
- Use this data on an ongoing basis to assist in planning and investment decisions

The main purpose of this work is to analysis the use of classroom utilisation effects on exam timetabling problem with a self-generating memetic algorithm. The results from the analysis show that classroom utilisation rates for exam timetabling problem should be addressed fully by top management. In addition, this study also suggests that in order to improve the utilisation rate, higher education institutes should think the occupancy rate as it is the critical element affecting the utilisation rate [7]. In the higher education sector, the most important result in terms of public investments of the growth policy on the establishment of new state universities since the middle of the 2000s and the contingent increases made in the existing universities has been the increases of investment demands [8].

129 State Universities, in the Republic of Turkey, have taken incentive to increase its number of students from 3.072.986 students in 2000 to almost 7.131.252 in 2020. These drastic increase of students enrolled has required Turkey to provide more space for teaching and learning facilities and other related supporting facilities. Turkey has to review and further investigate its teaching and learning facilities to cope with those changes. Therefore, we analyzed the effects of classroom utilisation for Space Management. The most important criteria in measuring the effective use of spaces is the space utilisation rate. Each academic semester in higher education institutions in Turkey, the number of students taking the exam in turkey about 21.103.312. However, Coronavirus disease 2019 (COVID-19) has changed the use of classroom. The usage capacity of the classes has been reduced by half and it is more difficult to conduct exams during the pandemic process. In this study, we added a new hard constraint to the exam scheduling problem by analyzing the educational space per student. The hard constraint is the classroom utilization rate that we used in the course scheduling problem we made before regarding this hard constraint.

2. Literature review

There are many investigators who have introduced methods and algorithms for solving ETP problem. In recent years, examination timetabling problems have been studied by using some new hyper-heuristic algorithms that have been shown to be very practical in other related problems. For example, graph coloring, simulated annealing approach, an iterative greedy algorithm, very large neighbourhood search, neural network, tabu search, multistage approaches utilizing case based reasoning, memetic algorithm, fuzzy reasoning, ant colony optimization, hyper-heuristics and hybrid approaches [9]. Evolutionary algorithms are the most frequently used methods for the ETP. Interested researchers can receive more information about examination timetabling study in [10] and [11]. Effective space inventory management relies on information about people, places, and processes. It supplies correct data to administrator by developing consistent space inventory system. The problem of space inventory management in the Turkish Public Universities are from the incorrect data, lack of centralized data administration and ineffective systems implemented. Space management practice requires continuous effort and slight progress has been made in raising awareness of space costs and possible for savings from improved space management. The most important criteria in calculating the space performance is how much the space is used. UK Higher Education Space Management Group (SMG, 2006) aimed to assist other higher education institutions in the definition and implementation of best application in efficient space management in their institutions. [12]. According to SMG the achievement of beneficial space

use may provide organizations with a fit-for-purpose physical asset and potentially release funds to supply greater quality of academic learning and student acquisition. Their objective is provided space management applications and good applicable information to institutions and funding committees to allow all to make reliable, rational and informed decisions regarding the property and university mission.

SMG has been studying on space management since 1960 and in year of 1996 published a survey. National Audit Office (NAO) has succeeded in publishing early guideline to present space utilisation study for their higher education institutions [13]. Later, different applications have been reported by SMG. Some higher education institutions use timetabling program for their study and others through examinations. Though there are differences, they attempt to accomplish the same purpose; to advance their space management procedures. There are two different problem of space allocation, a space utilisation and a constraint satisfaction/optimization [14]. In this study, we proposed a new approach to analyze the space utilisation. Table 1 presented the classroom utilisation values for some faculties.

Table 1. Classroom utilization rate for faculties

Academic Units	Number of Units	FR %	OR %	UR %	UFA m ²	Number of Students	UFA/ Number of Students m ²
Faculty of Applied Sciences	15	30,16	32,38	10	10.438,49	4.907	2,13
Faculty of Architecture	42	32,93	36,94	13,92	142.785,38	32.364	4,41
Faculty of Communication	53	23,04	27,72	7,54	105.430,93	58.978	1,79
Faculty of Economics and Administrative Sciences	124	39,92	42,89	19,82	600.309,78	325.804	1,84
Faculty of Education	90	34,67	36,46	15,22	656.819,10	216.015	3,04
Faculty of Engineering	107	28,39	30,47	10,73	1.240.641,91	293.134	4,23
Faculty of Fine Arts	61	27,8	30,98	10,38	255.407,87	32.984	7,74
Faculty of Health Sciences	95	30,69	32,58	12,09	214.501,39	96.294	2,23
Faculty of Technology	20	21,1	21,58	5,3	209.479,43	37.221	5,63
Vocational School	610	27,06	27,06	8,96	2.015.401,40	560.889	3,59
Average Scores		29,576	31,906	11,396			3,663

3. Modeling of Exam timetabling Problem

Educational timetabling problems are among the most studied scheduling problems including high school scheduling, university examination and course timetabling. In recent years, a huge number of papers published and many approaches have been developed to solve the timetabling problems. These problems draw much research effort due to its difficulty. Many benchmark problems in the exam literature still have not been solved to optimality. In this work, we concentrate on the ETP, which is one of the most significant administrative process that take place every educational organizations. The ETP comprises of the assignment of a set of exams to a certain list of periods subject to some constraints [15]. The number of examinations to be scheduled change greatly based on the institution. The created exam timetable which is called suitable timetable must satisfy all hard constraints of the problem, whilst violation of the soft constraints should be minimised. Soft constraints may not be satisfied, but in many circumstances, solution approaches try to minimize the number of violations as much as they can to raise the quality of a produced timetable further [16]. Tables 2 and 3 show the constraints of the exam timetabling problem.

Table 2. Hard Constraints

No	Hard Constraints
HC1	Assigning multiple exams to any student in the same time period should be avoided.
HC2	The capacity of a classroom can not be exceeded at a given period.
HC3	The exam durations should not violate the period length.
HC4	An exam may need to be scheduled before/after another
HC5	Schedule exam in a particular classroom (classroom-related hard constraints).

Table 3. Soft Constraints

No	Soft Constraints
SC1	Students should not take exams in successive periods and preferably not in the same day
SC2	The number of events in which a student takes two exams on the same day. If the exams assign back to back, SC1 violation is considered to prevent duplication.
SC3	Each group of student examinations should be distributed as equally as possible through the exam sessions.
SC4	Minimize the number of exams have a dissimilar length that is assigned in the same classroom.
SC5	Minimize the number of the largest exams are assigned close to the end of the exam session.
SC6	Minimize the number of exams scheduled in the period which have a related penalty.
SC7	Minimize the number of exams assigned in a classroom which have a related penalty.
SC8	Exam must be assigned to a classroom with lower utilization rate.

3.1. Problem Formulation

The variables used in the definition and formulations of the examination timetabling problem are given in Table 4:

Table 4. Definition of ETP

N	the number of exams
E_i	defines a collection of N examinations where $i \in \{1, \dots, N\}$
e_i	the number of students enrolled in exam E_i where $i \in \{1, \dots, N\}$
B	the set of all N exams, $B = \{E_1, E_2, \dots, E_N\}$
D	the number of days
P	the number of periods
M	the number of students
R	the number of available classrooms
L_f	the capacity of classroom f where $f \in \{1, \dots, R\}$
U_f	the utilisation rate of classroom f where $f \in \{1, \dots, R\}$
r_i	defines the assigned classroom for exam, where $r_i \in \{1, \dots, R\}$, $i \in \{1, \dots, N\}$
t_i	defines the assigned period for exam, where $t_i \in \{1, \dots, P\}$, $i \in \{1, \dots, N\}$
d_i	defines the assigned day for exam, where $d_i \in \{1, \dots, D\}$, $i \in \{1, \dots, N\}$
$C = (c_{ij})_{N \times N}$	defines a matrix in which each record indicated by c_{ij} , $(i, j \in \{1, \dots, N\})$ represents the number of students sitting exams E_i and E_j
$\Delta_t = t_i - t_j $	the period different between exam E_i and E_j
$\Delta_d = d_i - d_j $	the day different between exam E_i and E_j

The constraints of our dataset are described Eq.(1-10) [17]:

1) All exams must be assigned and each exam has to be assigned only once.

$$\sum_{s=1}^T \lambda_{is} = 1 \text{ for all } i \in \{1, \dots, N\}, \text{ where } \lambda_{is} = \begin{cases} 1 & \text{if exam } i \text{ is assigned to } s \\ 0 & \text{otherwise} \end{cases} \quad (1)$$

2) A student sitting in two exams concurrently (student-conflict) must not occur. If examination i and j are planned in slot s , the number of students taking both examination i and j must be equal to zero, i.e. $c_{ij} = 0$.

$$\sum_{i=1}^{N-1} \sum_{j=i+1}^N c_{ij} \cdot x(t_i, t_j) = 0, \text{ where } x(t_i, t_j) = \begin{cases} 1 & \text{if } t_i = t_j \\ 0 & \text{otherwise} \end{cases} \quad (2)$$

3) For each period t , the number of students enrolled exams ($Students_t$) cannot exceed the maximum capacity for each individual classroom ($Seats$).

$$Students_t \leq Seats \text{ for } t \in \{1 \dots P\} \quad (3)$$

4) Student who takes the exams on the same day consecutively should be assigned to the same classroom, i.e. both exams are assigned to the same classroom.

$$\text{If } t_i = x; t_j = x + 1; d_i = d_j \text{ and } c_{ij} \neq 0 \text{ then } r_i = r_j \text{ for all } i, j \in \{1, \dots, N\} \quad (4)$$

5) Particular examination, $E_i \in S$ where $S \subset B$ should be separated from other exams, i.e. the particular exam cannot share classroom with different exam at the same period.

$$\sum_{i=1}^N \alpha_{ir} \leq 1 \text{ for all } r \in \{1, \dots, R\}, \text{ where } \alpha_{ir} = \begin{cases} 1 & \text{if exam } E_i \in S \text{ is assigned to classroom } r \\ 0 & \text{otherwise} \end{cases} \quad (5)$$

6) No student can seat maximum number of exam consecutive exams in a day.

$$\text{If } c_{ij} \neq 0; c_{ik} \neq 0; t_i = x; [t_j = x + 1 \text{ or } t_j = x - 1] \text{ and } d_i = d_j \text{ then } d_k \neq d_i \text{ for all } i, j \in \{1, \dots, N\} \quad (6)$$

7) If it is possible, each examination must be assigned to one classroom.

$$\sum_{f=1}^R \beta_{if} = 1 \text{ for all } i \in \epsilon, \text{ where } \beta_{if} = \begin{cases} 1 & \text{if exam } i \text{ is assigned to classroom } f \\ 0 & \text{otherwise} \end{cases} \quad (7)$$

8) Exam must be scheduled to a classroom without exceed the classroom capacity.

$$\sum_{i=1}^N e_i \cdot \beta_{if} \leq L_f \text{ for all } f \in S \quad (8)$$

9) Exam must be assigned to a classroom with lower utilization rate.

$$\sum_{i=1}^N e_i \cdot \beta_{if} \leq U_f \text{ for all } f \in S \quad (9)$$

3.2. Fitness Function

The fitness function is based on Cost Penalty [18,19].

$$\text{Minimize } F = \frac{\sum_{i=1}^{N-1} \sum_{j=i+1}^N c_{ij} \cdot \text{Penalty}(t_i, t_j)}{M} \quad (10)$$

3.3. Classroom Utilisation Rate

Classroom Utilisation Rate Eq. (11): Classroom utilisation is a measure of whether and how space is being used. The utilisation rate is a function which comes from a frequency rate Eq. (12) and occupancy rate Eq.(13) [12]. Each classroom which has lower usage that is below 30 in a curriculum counts as 1 violation and below 75 in a curriculum counts as 2 violation.

$$\text{Classroom Utilisation Rate (UR)} = \frac{\text{Frequency Rate} \times \text{Occupancy Rate}}{100} \quad (11)$$

$$\text{Frequency Rate (FR)} = \frac{(\text{Number of hours used during exam periods}) * 100}{(\text{Hours allocated during exam periods})} \quad (12)$$

$$\text{Occupancy Rate (OR)} = \frac{(\text{Total student numbers during exam periods}) * 100}{(\text{Classroom capacity during exam periods})} \quad (13)$$

3.4. Parameters

There are various parameters for our self-generating memetic algorithm and the local improvement step of the algorithm. The self-generating memetic algorithm can be controlled via the following parameters:

Population size p : A small population size can lead to a less diverse population and not enough memetic material. However, with a large population size, it will take a long time to get the solution.

Construction strategy c : Sets the strategy to construct the initial population. Our strategy yields completely random solutions.

K-tournament competitors k : The number of competitors for the k-tournament in the selection phase of the algorithm. Must be in the interval $[1, p]$. Depending on the scores encoded in the meme of Parent1, crossover low-level heuristics, mutation low-level heuristics, local search low-level heuristics, and mutation density and depth of search values are chosen (using tournament selection). In any case, the operator or parameter setting with the best value among the tournament size of options, which indicates higher historical performance, is chosen. In the case of equal scores, the random option is selected [18, 19].

Depth of Search dp : This parameter controls the number of individuals to be improved in the local search phase of the algorithm. It lies in the interval $[0, 1]$. To get the number of individuals which are improved, it is multiplied with the population size p .

Intensity of Mutation im : The share of individuals to be mutated each generation is specified by this parameter. Must be in the interval $[0, 1]$.

Our parameter configuration is shown in Table 5.

Table 5: *Parameter configuration SGMMA.*

Parameter	Value sequence	Default value
Population size p	[10, 20, 50, 100]	50
K tournament competitors k^*	[0.0, 0.15, 0.35, 0.5]	0.15
Depth of Search dp	[0.2, 0.4, 0.6, 0.8, 1.0]	0.2
Intensity of Mutation mf	[0.2, 0.4, 0.6, 0.8, 1.0]	0.2

4. Self-Generating Multimeme Memetic Algorithm

A generic Memetic Algorithm (MA) as introduced by Moscato in [20], is an evolutionary algorithm which uses the feature of GA with some search heuristic algorithm like hill climbing, an iterative greedy algorithm, simulated annealing, tabu search etc. The main components of MA are crossover, mutation and local search. Members of the first population are produced using a weighted roulette wheel technique to select the period in which to place each exam in order to generate a high quality timetable. Mutation operators are divided into two, the light operator moving a number of exams to new available periods, the heavy operator disturbing whole periods. Hill climbing is then applied, taking the exams in each period in turn and checking all other periods to move an exam to the period of lowest penalty. The evaluation function penalises unassigned exams heavily as well as calculating the number of conflicts in the timetable between two periods on the same day. Roulette wheel selection is again applied during the selection phase in order to control a defined population size. In this work, we represent a useful Self-Generating Multimeme Memetic Algorithm (SGMMA) that manages to 6 mutational, 2 crossover and 2 local search operators. The first population is made up of using multiple constructive low-level heuristics with the aim of producing suitable initial solutions. The main characteristic of the suggested algorithm is that each meme encodes a score as a performance pointer of the associated operator. Finding efficient parameters for an algorithm is very challenging if a large number of parameters are available [21]. This is because the resulting combinatorial space of parameter settings is extremely large. Parameter tuning, if performed manually by hand, is tedious work. And if the number of parameters increase, the combinatorial space of parameter settings is too large to be managed manually. Self-adaptation is very important, if there is more than one operator and there are a number of values that can be

selected for from the parameter settings. Evolutionary algorithm can be categorized according to the adaptation type as steady, transgenerational, adaptive and self-adaptive. A steady-state algorithm is not taking into account any feedback during the search phase to modify the selection mechanism. On the other part, an adaptive algorithm uses online feedback to manage the selection of a local optimization algorithms. In this study, we propose a Self-Adaptive Multimeme Memetic Algorithm which employs a novel encoding for the self-adaptation of memetic operators and their parameter values. During the evolutionary phases, when it is time to use an operator of determined type, e.g., mutation, one of the operators is chosen and applied randomly using roulette wheel selection depend on the scores of operators of that type. The pseudocode for SGMMA is given in Algorithm 1.

Algorithm 1 Pseudocode of Self-Generating Multimeme Memetic Algorithm (SGMMA) for the ETP

```

1: Generate initial population of Population_Size random individuals
2: for  $i = 1 : Population\_Size$  do
3: OpID =Random-Select(Hill-Climbing-Operators)
4: Ind(i) Apply-Hill-Climbing(OpID,Ind(i))
5: end for
6: while termination criteria is not satisfied do
7: for  $i = 1 : Population\_Size - 1$  do
8: Parent1 ← Select-Parent(Population, tour-size)
9: Parent2 ← Select-Parent(Population, tour-size)
10: S_Meme = SELECTMEME(Parent1, Parent2) // S_Meme represents Selected Meme
12: OpID =Tournament Select(S_Meme.Crossover-Operators)
13: Offspring_Apply-Crossover(OpID, Parent1, Parent2)
14: UPDATEMEME(S_Meme, OpID, newfitness, oldfitness)
15: OpID =Tournament Select(S_Meme.Mutation-Operators)
16: Offspring_Apply-Mutation(OpID, Offspr)
17: UPDATEMEME(S Meme, OpID, newfitness, oldfitness)
18: OpID =TournamentSelect(S_Meme.Hill-Climbing-Operators)
19: Offspring_Apply-Hill-Climbing(OpID, Offspr)
20: UPDATEMEME(S_Meme,OpID,newfitness, oldfitness)
21: Add(Offspring,Offspring-Pool)
22: Tournament Select is based on number of operator best score of S_Meme.Operators
24: end for
25: Replacement: Offspring replaces the worst individual in the population
26: end while
27: function SELECTMEME(Parent1, Parent2)
28: if both parents carried the same meme then
29: MemeID =Meme.Crossover-Operator
30: elseif Parent1.fitness == Parent2.Fitness then
31: SelectedMeme=Random-Choice(Parent1.Meme, Parent2.Meme)
32: MemeID =SelectedMeme.Crossover-Operator
33: else
34: SelectedMeme=BestMeme(Parent1.Meme, Parent2.Meme)
35: MemeID= SelectedMeme.Crossover-Operator
36: end if
37: end function
38: function UPDATEMEME(S Meme,OpID, newfitness, oldfitness)
39: if newfitness:=oldfitness then
40: numberofoperatorworstscore++
41: else
42: numberofoperatorbestscore++
43: end if
44: end function

```

5. Numerical Results

The best and the average penalty from 10 independent runs are presented in the following Table 6. The performance of a self-generating multimeme memetic algorithm for the exam timetabling problem was analyzed on some instances from two universities. Each experiment is run for a notional duration of 325 seconds and repeated 10

times. Feasible timetables are gained from all instances used during the experiments. Table 6 provides that the best results gained by SGMMA for solving instances and Figure 1 shows that comparison of the UR. SGMMA performs pretty well and Classroom Utilisation Rate is between 30 and 70. It is not good algorithm, but it performs potentially greater than other evolutionary algorithms. It is further that other local search techniques may also be mixed in different steps of MA and can be tested on a number of different benchmark problems.

Table 6. Performance of SGMMA

Instance	Approach	Best penalty	Average Penalty	Utilisation Rate(%)
1	SGMMA	4	5	62.66
2	SGMMA	60	62	57.47
3	SGMMA	293	295	35.66
4	SGMMA	27	29	77.92
5	SGMMA	15	16	60.14
6	SGMMA	4	4	53.31
7	SGMMA	800	2000	47.76
8	SGMMA	52	55	45.42
9	SGMMA	11	11	45.45
10	SGMMA	5	6	27.22

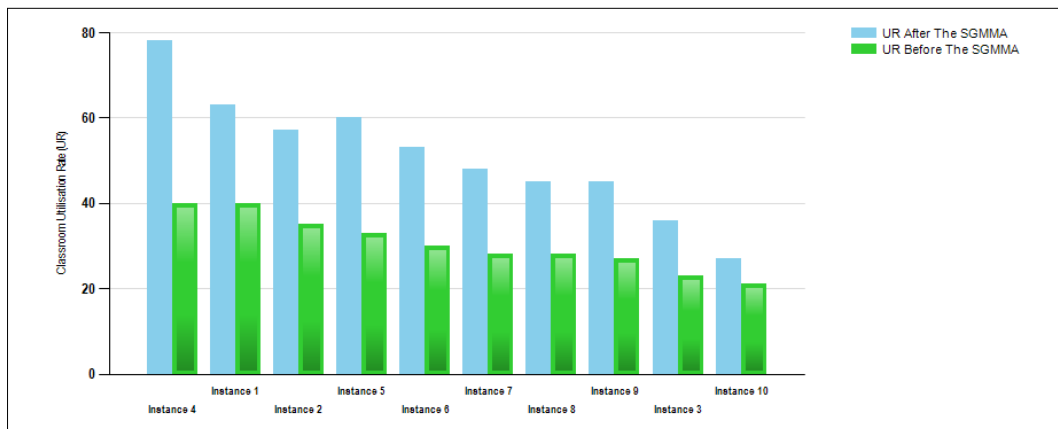

Figure 1. Comparison of Classroom Utilisation Rates After Applied SGMMA

6. Conclusions and Future Work

Evolutionary algorithm can be categorized according to the adaptation type as steady, trangenational, adaptive and self-adaptive. An adaptive algorithm uses online feedback to manage the selection of a local optimization algorithms. Parameter setting and control are very important in many evolutionary algorithms. Finding efficient parameters for an algorithm is very challenging if a large number of parameters are available. This is because the resulting combinatorial space of parameter settings is extremely large. Parameter tuning, if performed manually by hand, is tedious work. And if the number of parameters increase, the combinatorial space of parameter settings is too large to be managed manually. Self-adaptation is very important, if there is more than one operator and there are a number of values that can be selected for from the parameter settings. In this study, we propose a Self-Adaptive Multimeme Memetic Algorithm which employs a novel encoding for the self-adaptation of memetic operators and their parameter values.

We have successfully integrated MA's into the examination timetabling problem. We measured the space utilisation rate in two universities. We created new formula for new/additional hard constraint. In future we

plan to: use different algorithm and a more intelligent selection mechanism for choosing exam timetabling problem. Managing restricted spaces in the best way. Coronavirus disease 2019 (COVID-19) has changed the use of classroom, so it will become very important to increase classroom utilization rates using less capacity to adapt to this new situation. The usage capacity of the classes has been reduced by half or less and it is more difficult to conduct exams during the pandemic process. Furthermore, the effectiveness of expenditures based on space, one of the most important items of operating expenses of the universities, can only be achieved by rational space planning. We encourage to develop an effective space management system during the pandemic process.

Acknowledgements

The authors wish to thank Suleyman Demirel University Scientific Research Projects Management Unit Presidency that supported this Project financially with project number 4538-D1-16.

References

- [1] B. McCollum, P. McMullan, A. Parkes, E. Burke, R. Qu, A new model for automated examination timetabling, *Annals of Operations Research* 194(1), 291315 (2012).
- [2] Qu, R., Burke, E.K., McCollum, B., Merlot, L., Lee, S.: A survey of search methodologies and automated system development for examination timetabling. *Journal of Scheduling* 12(1), 55-89 (2009).
- [3] Muller, T.: Itc2007 solver description: A hybrid approach. *Annals of Operations Research* 172(1), 429-446 (2009).
- [4] Amaratunga, D., Baldry, D. (2000) Assessment of Facilities Management Performance in Higher Education Properties *Facilities Management*, 18(7/8), 293-301.
- [5] Pursglove, J., & Simpson, M. (2007). Benchmarking the performance of English universities. *Benchmarking: An International Journal*, 14, 102-122.
- [6] Rogers, C. (2002). *Space Management in Higher Education: Report of the Findings of the Newcastle University Space Management Project, Jointly Funded by the HEFCE Good Management Practice Programme and the University* (pp. 1-88). Newcastle: University of Newcastle.
- [7] HEFCW. (2002). *Space Management: A Good Practice Guide*. Swansea: University of Wales.
- [8] SCHEV. (2004). *Space Utilization and Comparison Report*. Richmond: State Council of Higher Education for Virginia.
- [9] Tan, J. S., Goh, S. L., Kendall, G., & Sabar, N. R., A survey of the state-of-the-art of optimisation methodologies in school timetabling problems. *Expert Systems with Applications*, 165, 113943, (2021).
- [10] C. Gogos, P. Alefragis, E. Housos, A multi-staged algorithmic process for the solution of the examination timetabling problem, in: *Practice and Theory of Automated Timetabling (PATAT 2008)*, Montreal, 19-22, August (2008).
- [11] M. Atsuta, K. Nonobe, T. Ibaraki, Itc2007 track 1: An approach using general csp solver, www.cs.qub.ac.uk/itc2007.
- [12] Space Management Group. (2006). *Space Utilisation: Practice, Performance and Guidelines*. London.
- [13] NAO. (1996). *Space Management in Higher Education: A Good Practice Guide*. London: National Audit Office.
- [14] Aziz A. A., Hashim A. E., Baharum Z. A. (2013). *Space Inventory Management in the Malaysian Public Universities* *Social and Behavioral Science*
- [15] G. De Smet, Itc2007 - examination track, in: *Practice and Theory of Automated Timetabling (PATAT 2008)*, Montreal, 19-22, August (2008).
- [16] N. Pillay, A developmental approach to the examination timetabling problem., in: *Practice and Theory of Automated Timetabling (PATAT 2008)*, Montreal, 19-22, August (2008).
- [17] B. McCollum, P. McMullan, A. J. Parkes, E. K. Burke, S. Abdullah, An extended great deluge approach to the examination timetabling problem, in: *The 4th Multidisciplinary International Conference on Scheduling: Theory and Applications (MISTA09)*, Dublin, (2009).
- [18] E. Özcan, et al., A self-adaptive multimeme memetic algorithm co-evolving utility scores to control genetic operators and their parameter settings, *Applied Soft Computing* 49,81-93, (2016).
- [19] S. Abdul-Rahman, A. Bargiela, E. K. Burke, E. Ozcan, B. McCollum, Linear Combination of Heuristic Orderings in Constructing Examination Timetables, *European Journal of Operational Research*, 232(2), 287-297 (2014).
- [20] P. Moscato, On evolution, search, optimization, genetic algorithms and martial arts: Towards memetic algorithms, *Caltech concurrent computation program, C3P Report*, vol.826, p. 1989, (1989).
- [21] Huang, C., Li, Y., & Yao, X., A survey of automatic parameter tuning methods for metaheuristics. *IEEE transactions on evolutionary computation*, 24(2), 201-216, (2019).

Encryption Methods and Comparison of Popular Chat Applications

Muhammed Burak KILIÇ^{1,*}

¹ Mugla Sıtkı Koçman University, Technology Faculty, Information Systems Engineering, Turkey
0000-0002-7503-9191

Abstract

In each period experienced in the field of communication as was the case in many areas of the peculiar and exceptionally experienced security problems brought by the era and continues to be experienced. However, in today's global world, this problem is accelerating day by day and increasing exponentially. Many data (photographs, videos, sound recordings) that should be kept confidential based on individual or society have become the limits with the developing technology. The purpose of the article is to propose end-to-end encryption provided chat applications where user individuals can exchange private information securely. The list of needed to develop a secure chat application has been presented in the article.

Keywords: *Secure chat applications; encryption methods; end-to-end encryption.*

1. Introduction

Although communication has been taking place in different forms since humanity existed, interaction is at its core. For instance, letters and telegrams have been replaced by text messages and e-mails with the widespread use of the internet. As the internet-based instant messaging applications provide more mobility than any other communication devices perhaps we can access, these applications have been increasing together with the constantly developing technology. According to Statista, a German company specializing in market and consumer data research, there are 41.9 million smartphone users in Turkey by 2018, and by 2025 this number will reach 72.5 million. [1]

Mobile devices have become an irreplaceable part of daily life with the rapid development of mobile phones. Correspondingly, chat applications have also developed and created a big change in social media in recent years due to their unique and special features that attract the masses. [2]

Users can easily share text messages, pictures, videos, and files using chat apps, which provide real-time messaging. Nearly all major messaging apps are currently available on Android and iOS operating systems and are being used by hundreds of millions of people. [3]

These applications have two different types. Which are client-server and peer-to-peer. P2P networks do not have a central server, and each user has their own data storage. [4] However, in the Client-Server network, data is stored on a central server. Client-Server network contains servers and clients used for processing. [4, 5]

Security and privacy are essential in these chat apps for all users; however, communities were far from actually what happened to their data and who could view those, until the WhatsApp Privacy Policy change on February 8, 2021. Encryption was initially thought to be paranoid or used by people with a high need for privacy. In reality, users have become more aware of the importance of data privacy and the dangers of identity theft after the revelations of hacker groups, and Edward Snowden, an American computer expert and former CIA and NSA employee. [6]

Accordingly, applications that have been around for years, research and updates to meet users' privacy, and demands in this direction have started to increase. Until the last few years, most applications have only used Transport Layer Security (TLS) to ensure security in special situations. As a result, the service provider was able to access any message it wanted. [7]

Therefore, these messages could also be accessed by attackers, so there was major security vulnerability. For this reason, to protect the confidentiality of messages, messages must be encrypted from sender to recipient, and the device's local storage must also be protected so that messages cannot even be read by service providers.

2. Cryptography

Cryptography is the science of ensuring the protection and security of the privacy of information. In our increasingly digital world, the encryption methods used for website or message/content security have their roots thousands of years ago. Although we define it as primitive today, the beginning of this science, which is still developing now, dates back to the early days when communication start to exist.

*Corresponding author

E-mail address: mdburakkilic@gmail.com

2.1. Encryption and Keys

Encryption is used to store or transmit data so that it can only be read and used by certain people. From the flat state it is, data can be encrypted or decrypted using symmetrical or asymmetric encryption systems that use one or more keys according to status and need to convert it to encrypted form. The same key is used to encrypt and decrypt messages or data in symmetric encryption. Asymmetric encryption uses a public key as the encryption key and a private key to be used for the decryption solution (**Figure 1**).

2.2. Digital Signatures and Authentication

It is a cryptographic system used to verify the authenticity of data in a digital environment.

2.3. Key Exchange

It is a method by which encryption keys between two parties are securely exchanged, aiming to securely transmit messages or data using encryption.

3. Encryption Types

In modern encryption methods, two main encryption methods are often used. Symmetric encryption, where a single key is used to encrypt and decrypt the content, and asymmetric encryption, where secret (private) keys are used for public decoding for encryption.

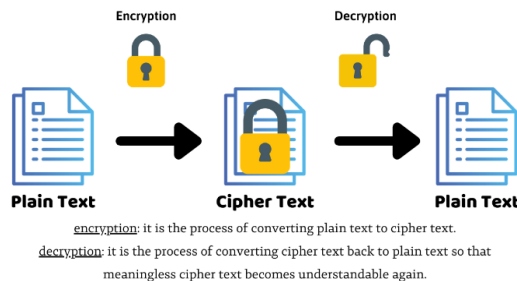

Figure 1. Encryption and Decryption

3.1. Symmetric Encryption

This type of encryption is the use of the same key or passwords to encrypt data or access the original state of encrypted data as seen in **Figure 2**. For this type of encryption, the Secret Key is used to encrypt and decrypt the data. These secret keys are usually 128, 192, and 256 bits in size, but are also called encryption key or shared key because both the sender and the receiving party need to know. Most applications use certain existing passwords as keys, which is because it is easier for users to remember than data on the binary system. Modern cryptography symmetric encryption algorithms use AES (AES-128, AES-192, AES-256) as broadcasts.

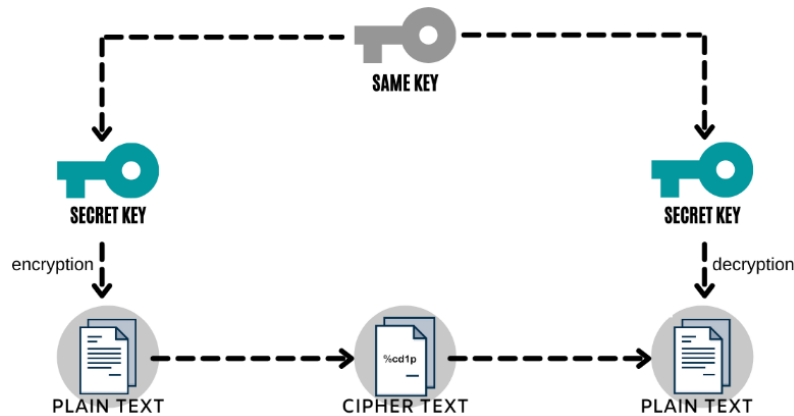

Figure 2. Symmetric Encryption Structure

3.2. Asymmetric Encryption

In asymmetric encryption systems as seen in **Figure 3**, data is encrypted with a public key and used to decrypt and authenticate data encrypted with a private key. Data encrypted with a public key can only be resolved thanks to the corresponding private key. The data obtained after the encryption process is a binary sequence that cannot be read by individuals and cannot be decrypted by design without a decryption key.

Public key encryptions can typically encrypt limited-size messages, and symmetrical and asymmetric encryption can be used together for PDF or larger data or messages.

The most well-known methods for asymmetric encryption are RSA and ECC encryption methods.

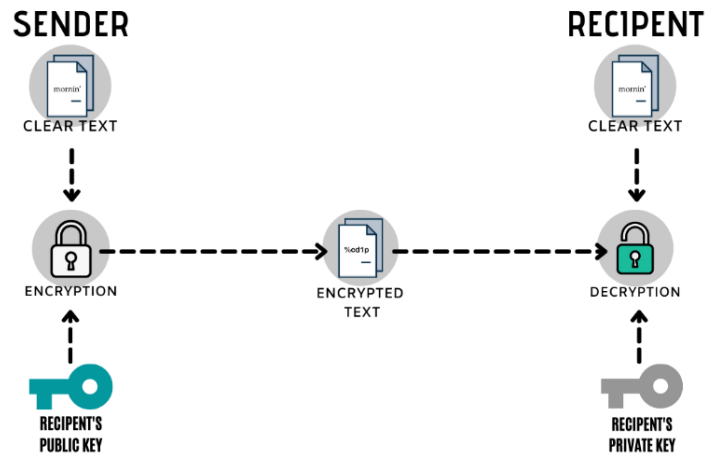

Figure 3. *Asymmetric Encryption Structure*

4. Encryption Algorithms and Methods

Modern encryption methods can be examined in different classes: symmetric, asymmetric and digital signature in key characteristics. For symmetric encryption, the sender and recipient share an encryption key and / or a decryption key. These two switches are usually the same or in case are easy to understand. There are two main standards for symmetric encryption. These are known as DES and AES. For asymmetric encryption, the receiving has a key and a private key. In this context, the public key can be shared, the private key must be kept private. Both RSA and ECC standards can be used in asymmetric encryption. In addition, the MD5 and SHA standards are included digital signature.

The encryption algorithms used are symmetrical, asymmetric, and hybrid (hash) encryption algorithms in which these two approaches are used together. Encryption techniques will make data more secure on the local system or the cloud system where it is stored.

AES: Advanced Encryption Standard is a symmetric key standard. Each of these passwords has a block size of 128 bits, with key sizes 128, 192, and 256 bits, respectively.

DES: Data Encryption Standard is the most widely used encryption algorithm. It works on one-size flat text blocks and is used to encrypt large data.

RSA: RSA is an algorithm used for public-key encryption which contains a public and private key. The public key here is known to the public and to encrypt submissions. Messages encrypted with a public key can only be decrypted using a private key. User data protected in this way includes pre-storage, retention or retrieval, authentication of users, and creation of secure channels for data transfer.

MD5: MD5 is an algorithm which can be used for encryption algorithms. With this algorithm, a variable-length message is like 128-bit fixed-length output. The input message is divided into 512-bit blocks; the message is filled in so that its length will be divided by 512. This sender uses a public key and the recipient uses a private key to decrypt the message.

ECC: Elliptic Curve Cryptography features modern public-key encryption systems based on the challenge of the elliptical curve discrete logarithm problem. ECC implements all of the asymmetric encryption system features of encryption, signatures, and key exchange. It is considered a more modernized version of the RSA system, which is because the ECC uses smaller switches than RSA for the same level of the security process, resulting in much faster key generation and faster key interaction.

SHA: Secure Hash Algorithms define hash algorithms used in modern encryption. SHA-2 includes strong encryption hash functions: such as SHA-256, SHA-512, and so on. Legacy hash algorithms such as MD5, SHA-0, and SHA-1 contain cryptographic weaknesses. However, the SHA-2 family is considered extremely safe.

MD5, AES, ECC Hybrid Approach: Symmetric and asymmetric key encryption algorithms are used together to increase the level of security. In this approach, the actual data is encrypted with the MD5 algorithm, and the encrypted file is also encrypted by providing 3-level encryption with AES and then ECC.

5. Mobile Chat Applications

This section will include an overview of signal, WhatsApp, Telegram, Facebook Messenger, which are considered the best and most secure applications as can be seen from **Figure 4** [8]. The security and privacy features are very important for Messaging Apps. The general summary regarding this can be seen in **Table 1**.

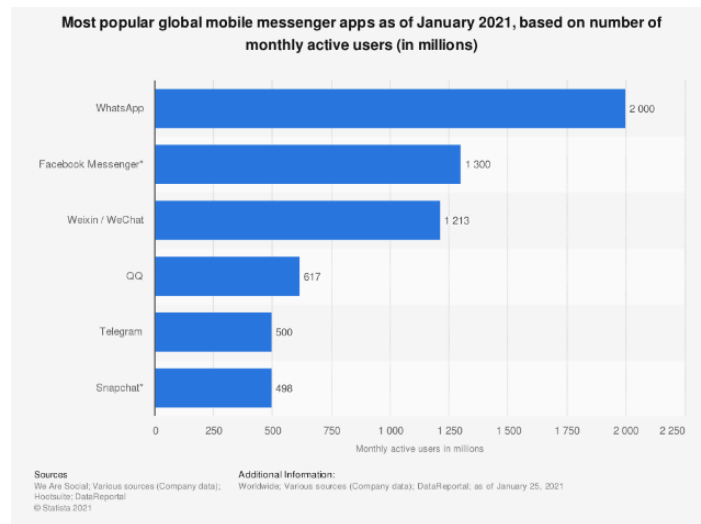

Figure 4. *The Most Popular Global Messaging Apps*

5.1. WhatsApp

WhatsApp is now one of the most popular messaging apps globally with more than two and a half billion active users [9] Messages between a sender and recipient using WhatsApp client software released after March 31, 2016 use the Signal protocol for voice and video calls [10]. Designed by Open Whisper Systems, this Signal Protocol forms the basis of WhatsApp's end-to-end encryption algorithm. This end-to-end encryption protocol is designed to prevent third parties other than the sender and receiver and WhatsApp from having direct plaintext access to messages or calls.

5.2. Signal

Signal was first used in 2010 to send encrypted messages and was developed by Whisper System's Moxie Marlinspike and Stuart Anderson and was known as a proprietary app under the name TextSecure. [11, 12] The Signal Protocol was developed by Open Whisper Systems in 2013 [13]. This protocol, rooted in TextSecure, provides end-to-end encryption, and today WhatsApp [14], Facebook Messenger, and Signal applications also use it [15]. The application uses end-to-end encryption at the military level.

5.3. Telegram

Telegram, which was officially launched in 2013, is one of the most used and considered safe applications today. Telegram, which offers an open-source messaging service, uses its own cryptographic encryption protocol, MTProto [16].

It supports two layers of secure encryption on its basis. Server-client encryption is used in cloud chats, i.e. private and group chats. Private chats use an additional layer of client-client encryption. It is encrypted in the same way, regardless of text, media, or file type. Encryption operations are based on 256-bit symmetric AES encryption, 2048-bit RSA encryption, and Diffie-Hellman key exchange [17].

5.4. Facebook Messenger

Facebook Messenger is a popular messaging service available for Android and iOS. It provides two messaging modes for normal (standard) chat and private chat (conversations). Standard chat uses only TLS, does not provide end-to-end encryption, and stores all messages on its servers. Messages in confidential

conversations use Signal Protocol to provide end-to-end encryption between sender and recipient. Third parties other than speech – including Facebook – cannot access message texts and messages can only be decrypted by the requested recipient [18].

Table 1. Security and Privacy Features of Messaging Apps [19]

Messaging App	End-to-end encryption	Private key not accessible by provider	Deleted from Server	Self-Destruct Messages	Open-Source	Password lock	Verification SMS/Email	Two-step Verification	Remote logout	Free
Line	✓						✓			✓
Messenger	✓ (optional)			✓						✓
Signal	✓			✓	✓	✓				✓
Skype	✓ (optional)									✓
Slack										✓
Snapchat	✓									✓
Telegram	✓ (optional)	✓		✓	✓	✓		✓	✓	✓
Viber	✓	✓	✓	✓		✓				✓
WhatsApp	✓	✓				✓	✓			✓

6. Key Exchange and DHKE

6.1. Key Exchange

In cryptography, key exchange is a method by which keys are exchanged (exchanged) between two parties, thereby using an encryption algorithm.

If the sender and recipient want to exchange encrypted messages, each must be authorized to encrypt the messages to be sent and decrypt the received messages. The encryption that is needed depends on the technique that can be used as the basis. According to the encryption system, they will need different types of keys. If the password is a symmetric key password, both will need a copy of the same key. In asymmetric key encryption with public/private key capability, both will need the other's public key. [20]

By design, key exchange schemes securely exchange cryptographic keys between two parties so that no one else can access a copy of the keys. Key determination design occurs when a laptop connects to a wireless internet network or when a website is opened through a specific protocol. This key determination can be based on an anonymous key exchange protocol, a password, or the combination of many learning.

There are many cryptographic algorithms available for key exchange and key generation. Some of these algorithms use open-key encryption systems, some use simple key exchange methods, some may include server authentication, and some may include client authentication. This article will include one of the first public-key protocols, the Diffie-Hellman Key Exchange.

6.2. Diffie-Hellman Key Exchange

The Diffie-Hellman key exchange algorithm, the first public-key algorithm announced, is based on the process of safely changing a key between two users over a public (unsafe) environment. Since the DH method is an algorithm that only provides key exchange, keys changed after the process are then used for encrypted communication.

At its core is the process of generating public secret keys that can be used in secret communications. This key also ensures secure data exchange on public (untrustworthy) networks.

For a better understanding of the Diffie-Hellman Key Exchange protocol, we can use the key exchange visual sample by mixing the best-known colors. (Figure 5)

The design of the color mixing and key change scheme proceeds on the assumption that if there are two different colors, we can easily mix these colors and make a new color. Reversal is almost impossible, as there is no clear management or way to parse mixed colors into their original colors.

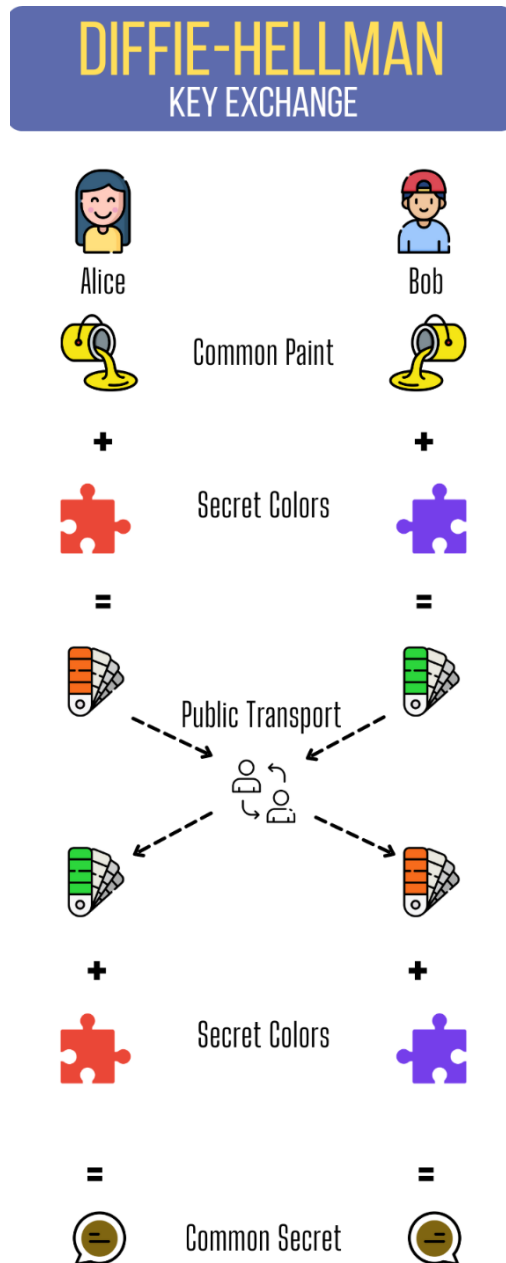

Figure 5. Diffie-Hellman Key Exchange Algorithm

To explain with a classic example: Alice and Bob identify a common color between them that is accessible to everyone. In our example, let's consider the color yellow. Then they choose a hidden color that only they know. (red and blue)

This hidden color is mixed with the common color originally specified, and the resulting new colors are exchanged in a way that is also accessible to third parties. This does not cause security weaknesses because there is no easy and effective way to parse these mixed colors.

Finally, Alice and Bob mix the color they get from each other with the hidden color they set themselves, and as a result, they get a common color. The common color obtained as a result of the operations represents the common secret between them.

Even if the color changes made explicitly are known, the probability of access to the color at the end of the process is very low because the hidden colors determined by the users are unknown. In the Diffie-Hellman Key Exchange method, modular bases are used instead of color, which is one of the reasons why this process is safe.

7. Result and Recommendations

In this study, the definition and how terms such as encryption and key, digital signature, and key exchange are used for cryptography and then cryptography are discussed. Then there is the structure and functioning of symmetrical and asymmetric encryption algorithms, the two main types of encryption used for modern encryption operations.

Symmetric encryption is an encryption method in which the sender and receiver use a public key for both encryption and decryption. Although encryption is faster with this method, it can cause a number of security vulnerabilities because the sender and recipient will need to securely change their keys. AES and DES are popular standards for symmetric encryption.

Asymmetric encryption uses two different keys to encrypt and decrypt data. One key here is used for encryption, while the other is a common key-based encryption method that is used to decrypt. Where the sender encrypts the message with the public key, the recipient uses the private key created to decrypt the same password. To protect privacy and authentication, encryption is based on the rule that the public key does the encryption and decrypts with the help of the private key. RSA, ECC, and DHKE are frequently used, popular public-key encryption systems.

Based on the algorithms used after basic encryption methods, comparisons of existing popular chat applications and their chat and data security features are included.

In the study, the DHKE method was mentioned and information about its structure and functioning was given. The Diffie-Hellman method is based on the key exchange structure and is the first open key algorithm announced. This key exchange algorithm is a method used to change cryptographic keys securely or confidentially.

References

- [1] J. Degenhard, "Forecast of the number of smartphone users in Turkey from 2010 to 2025", 2021. Available: <https://www.statista.com/forecasts/1146422/smartphone-users-in-turkey>.
- [2] A. Read, "How Messaging Apps Are Changing Social Media", 2016. Available: <https://blog.bufferapp.com/messaging-apps>.
- [3] H. Tankovska, "Most popular global mobile messenger apps", 2021. Available: <https://www.statista.com/statistics/258749/most-popular-global-mobile-messenger-apps/>.
- [4] N. Sabah, J. M. Kadhim ve B. N. Dhannoon, "Developing an End-to-End Secure Chat Application", International Journal of Computer Science and Network Security, no. 17, pp. 108-113, 2017.
- [5] D. Moltchanov, "Client/server and peer-to-peer models: basic concepts", Department of Communications Engineering, Tampere University of Technology, 2013.
- [6] B. Muqet, "Best Secure Messaging Apps for Android and iOS", 2018. Available: <https://www.privacyend.com/best-encrypted-messaging-apps/>.
- [7] M. Kleppmann, "The Investigatory Powers Bill would increase cybercrime", 2015. Available: <https://martin.kleppmann.com/2015/11/10/investigatory-powers-bill.html>.
- [8] C. Corrigan, "The Very Best Encrypted Messaging Apps", 2020. Available: <https://www.avg.com/en/signal/secure-message-apps>.
- [9] M. Iqbal, "WhatsApp Revenue and Usage Statistics (2021)", 2021. Available: <https://www.businessofapps.com/data/whatsapp-statistics/>.
- [10] WhatsApp, "WhatsApp Encryption Overview [Technical white paper]", 2020.
- [11] C. Garling, "Twitter Open Sources Its Android Moxie", 2021. Available: <https://www.wired.com/2011/12/twitter-open-sources-its-android-moxie/>.
- [12] A. Greenberg, "Android App Aims to Allow Wiretap-Proof Cell Phone Calls", 2010. Available: <https://www.forbes.com/sites/firewall/2010/05/25/android-app-aims-toallow-wiretap-proof-cell-phone-calls/>.
- [13] K. Ermoshina, F. Musiani ve H. Halpin, "End-to-End Encrypted Messaging Protocols: An Overview", %1 içinde International Conference on Internet Science, Floransa, 2016.
- [14] WhatsApp, "WhatsApp Encryption Overview", 2020. Available: <https://www.whatsapp.com/security/WhatsApp-Security-Whitepaper.pdf>.
- [15] Facebook, "Secret Conversations", Available: <https://www.facebook.com/help/messenger-app/1084673321594605/>.
- [16] Telegram, "Security", Available: <https://telegram.org/faq#security>.
- [17] Telegram, "Telegram FAQ", Available: <https://telegram.org/faq#q-so-how-do-you-encrypt-data>. [Erişildi: 2021].
- [18] Facebook, "Messenger Secret Conversations [Technical white paper]", 2017.
- [19] J. Botha, L. Leenen ve C. Van 't Wout, "A Comparison of Chat Applications in Terms of Security and Privacy", %1 içinde 18th European Conference on Cyber Warfare and Security, 2019.

- [20] Wikipedia, “Key exchange”, Available: https://en.wikipedia.org/wiki/Key_exchange.
- [21] Statista, “Most popular global mobile messenger apps as of April 2021, based on number of monthly active users”, 2021. Available: <https://www.statista.com/statistics/258749/most-popular-global-mobile-messenger-apps/>.

Educational Aspect Of History Themed Strategy Type Computer Games

Muhammet Emin Varelci ¹,

¹ Mugla Sitki Kocman University, Information Systems Engineering, Mugla, Turkey

Abstract

In the study carried out, a general evaluation was made by examining the educational aspect of computer games in the category of history-themed strategy games and their relationship with education. As a result of the researches, it has been seen that these games with artificial intelligence contribute to the development of students' intellectual skills and increase their success in their lessons. Today, with the rapid development of technology and its active use in many areas of life, it has become a necessity to be included in the education-teaching processes. The use of computer games in education by programming has created many educational facts on a geographical basis, especially in history.

Keywords: *Computer games, History, Strategy, Technology, Education, Teaching.*

1. Introduction

New developments and regulations in the field of information and technology, on behalf of "Information It has reached the position of being the beginning of a new age called the "Age to the needs of society able to respond, be aware of the relationship between the concepts learned, It is in the stage of creation, which is assimilating by organizing and the last step of the bloom taxonomy.

Traditional education throughout history to raise individuals who can produce new products such as understanding of the modern age in educational activities by gaining a different perspective other than the understanding of make efficient use of technology to provide an appropriate understanding of development required [1].

Development and reform movements in every field emphasize the importance of education. The process of acquiring knowledge of our age does not depend only on the school environment, but also on the whole life. It has spread over a wide area to shape it [2].

Another issue is computer games; reaching huge audiences via the internet active for the purpose of entertainment, where individuals from all age groups can evaluate their time. They are a platform. As individuals are against artificial intelligence, they are also synchronized with each other. They can also play (synchronously). This situation shows how big computer games are. Indicates that it may have a domain. The ultimate purpose of computer games is to educate the users while at the same time entertaining them. Issues that should not be overlooked in terms of computer games; computer what is included in the content of the games, what kind of computer activities individuals enjoy, implicit teaching, which computer games both entertain and transfer to individuals what their purpose is [3].

Researching how computer games can contribute to courses such as history and geography, Kurt D. Squire is based on the game "Civilization III", based on the 2004 "Replaying History" title prepared his thesis. This study aims to explain the contribution of the students from the games in their education-teaching processes. Solving problems by playing the game "Civilization III" to some students. Skills, knowledge of geography, past civilizations in history and present-day countries. The students who played games were compared to those who did not.

They achieved better results in many subjects compared to [4]. The aim of this study; have fun with historical and strategic computer games. Apart from spending time, the educational contributions it offers to individuals are the subject of many researchers. The reviews about the importance of games in education by scanning sources and documents to compile data.

2. Computer Games and Education

Computer games are a set of various software, supported by graphics, shaped by the hand-eye coordination of individuals, containing the state of "interacting" and containing many sub-titles [5].

Computer games, which are an output of the synthesis of information and technology, offer players an area where they can interact with each other in a three-dimensional environment with a development process of fifty years, and in this area, individuals reveal their cognitive and sensory abilities in the virtual environment and at the same time.

*Corresponding author

E-mail address: emin.vrc@hotmail.com.tr

They are three-dimensional environments where they can provide interactive communication [6]. While it covers all the activities that are dependent on a purpose, aiming to reach the goal by following the rules determined during the planning phase, and in which individuals play an active role, all of the activities that bring many skills such as acquiring new information, ensuring the transferability of the acquired knowledge to different environments, and discovering their own self-efficacy are called educational games [7].

In order for educators to use educational games as a method in education and training processes, they should plan ahead and choose the educational game while serving the purpose. It should be chosen by taking into account the developmental characteristics of the individuals who will play. In addition to being interesting, the games are conveyed with a simple and clear expression technique in which all students can participate actively, the rules of the game can be perceived by all students. It is foreseen that it will be more beneficial for the teacher to give feedback, corrections and reinforcements on behalf of the whole class in the form of a general address, and that the mistakes of the students who make mistakes while playing the game should not be emphasized too much, and it is foreseen that teachers can use various types of educational games in their lessons within the framework of these issues [8].

Howard Gardner, who works on the field of educational science, has revealed various theories and opinions by considering the situations where traditional education methods are insufficient because each person's mind structure is different. One of these theories is "Multiple Intelligence Theory". On the basis of the theory, it has been determined that the use of materials that appeal to more than one sensory area such as maps, documents, cartoons, videos and music clips in education facilitates history teaching, apart from other teaching areas [9].

In short, computer games provide the opportunity for individuals to continue their education by increasing their acquisition efficiency, ensuring their meaningfulness, and approaching events from different angles.

3. Computer Games and Education

A historical themed strategic computer game; It includes political, geographical, sociological, military elements at a certain time in real world history. In addition, it offers the opportunity to change the course of history and events in the game with the moves that the user will perform on his own. Although the gameplay of most games is similar, their dynamics and game engine are different. It this situation offers users the opportunity to turn to games according to their interests.

3.1. Hearts of Iron

The Hearts of Iron series is a strategy-focused game set in the World War II era published by Paradox Interactive as seen in **Figure 1**. The series has four games so far, the last of which was released in 2016. With Hearts of Iron IV, users start their game by choosing one of two dates, 1936 or 1939. Players who choose the first date can prepare for the Second World War or choose the date 1939 and start the war directly. In the game, you can produce factories, surround the country with railways and develop economy and production. There are three types of production facility options as military, civilian and shipyard. Countries can produce their unique planes, rifles and ships in accordance with their history. It can be chosen which policies the country will focus on in various areas. It offers the opportunity to focus on ground forces, air forces, industry and many more. For example; It highlights names such as Mustafa Kemal Atatürk, Ali Fuat Cebesoy, Kazim Karabekir, Ahmet Ali Celikten, Nihal Atsız, who have important traces in the history of the Republic of Turkey, in politics, and can be adapted to the modern world by making gains. With the focus tree, the country can be moved towards a specific goal. With the elections, those events can be realized in accordance with the historical trend or an alternative history can be kept alive. For example; when played with Turkey, you can sign the Sadabad pact, establish the Anadolu Agency, or claim rights within the borders of the National Pact. The mentioned guiding phenomena are also present in other states and include the historical events and ideals of those nations.



Figure 1. Hearts of Iron IV

The Hearts of Iron series is a strategy-focused game set in the World War II era published by Paradox Interactive. The series has four games so far, the last of which was released in 2016. With Hearts of Iron IV, users start their game by choosing one of two dates, 1936 or 1939. Players who choose the first date can prepare for the Second World War or choose the date 1939 and start the war directly. In the game, you can produce factories, surround the country with railways and develop economy and production. There are three types of production facility options as military, civilian and shipyard. Countries can produce their unique planes, rifles and ships in accordance with their history. It can be chosen which policies the country will focus on in various areas. It offers the opportunity to focus on ground forces, air forces, industry and many more. For example; it highlights names such as Mustafa Kemal Atatürk, Ali Fuat Cebesoy, Kazım Karabekir, Ahmet Ali Celikten, Nihal Atsız, who have important traces in the history of the Republic of Turkey, in politics, and can be adapted to the modern world by making gains.

With the focus tree, the country can be moved towards a specific goal. With the elections, those events can be realized in accordance with the historical trend or an alternative history can be kept alive. For example; when played with Turkey, you can sign the Sadabad pact, establish the Anadolu Agency, or claim rights within the borders of the National Pact. The mentioned guiding phenomena are also present in other states and include the historical events and ideals of those nations. The technological developments of that time in the world were also reflected in the game with the researches. For example; With Turkey, you can develop the aircraft produced in TOMTAS Aircraft Factory or produce the M38 Kirikkale rifle. With diplomacy, countries can provoke each other to war, and they can cause rebellion by interfering in internal affairs. In accordance with the course of history, countries may join the war on the side of the Allies or the Axis Powers.

By making trade, raw material exchange between countries is ensured. Every country has the chance to use its own natural wealth or the tools it produces in trade. For example, while there is oil-based production in Iraq, there is production on Chrome and Steel in Turkey. While the soldiers who cannot adapt to the geographical conditions on the battlefield can perish quickly, the armies that are not inclined to the cold may perish in the snow. Hearts of Iron IV allows students to reflect on the historical events of the Second World War and to interpret events and developments from a different perspective. It helps students to better understand the balance of the world at that time, who was influential in the decision-making mechanisms of states, and what targets they were advancing by comparing them with what they saw in the lesson.

3.2. Europa Universalis

The Europa Universalis series is a strategy game set between 1444 and 1821, released by Paradox Interactive (**Figure 2**). There are four games in the game's series so far, and the latest game Europa Universalis IV was released in 2013. The user can start the game on any day-month-year date between the years mentioned above and can carry his civilization to the future by taking over the state of the state he chooses at that time.

The game offers you the opportunity to choose all the states you want on that date at the beginning. Whoever is the ruler in that country on the chosen date is reflected in the game along with the characteristics of that historical person? You can take people who have left their mark in history as consultants, and you can benefit from their abilities by appointing them as commanders of armies. For example; For the Ottomans, you can appoint Mimar Sinan as advisor, Oruc Reis as admiral, and Sokullu Mehmet Pasha as general.

With policy management, laws enacted by rulers in the past are also present in the game and can be implemented. For example; In the Ottomans, incomes increase by taking the Cizye Tax, but the non-Muslim people are uneasy about this situation. Again in the Ottomans, the country gains stability when the laws of Süleyman I (Kanuni) are approved.

The game, which also makes America and the African Continent discoverable, allows you to colonize the underground riches of those places. For example; Thanks to its geographical proximity, Portugal begins to colonize the eastern part of South America, namely Brazil, faster than other countries. Military units have been added to the countries themselves and their history. For example; while the Ottomans could use the Pedestrian Troops in the early days, as the technology developed, the Janissaries and later the Nizami Cedid infantry could be used.

The periods in history were reflected in the play with the institutes. The process that started with feudalism continues as Renaissance, Colonization, Printing, Global Trade, Factoryization and Enlightenment. On this occasion, players can see important steps in the history of the world. With the tasks given, the country is encouraged to act in parallel with the flow of history. Whatever the missions and goals of the countries in history, these features are reflected in the game exactly. For example; The conquest of Istanbul in the Ottomans, the unity of Anatolia, Eastern Anatolia, the Balkans, Egypt, North Africa, the Arabian Peninsula were presented to the player in the form of a task in accordance with the historical order.

While Europa Universalis allows students to see the history of the world in depth and from many different angles in a 400-year cross-section; interpret the conditions and developments of that time. Real Continuing in parallel with the historical flow, it helps the countries to experience their goals, gains or losses in addition to what is explained in the course.



Figure 2. Europa Universalis IV

3.3. Crusader Kings

The Crusader Kings series is a medieval strategy game released by Paradox Interactive as seen in **Figure 3**. There are three games in the series of the game so far, and the latest game, Crusader Kings III, was released in 2020. Game; it mainly deals with dynastic rule, state administration and periodic wars. Dynasties and feudal lords in the states of the time were transferred in accordance with history. While developing the game, the weight was given to state administration, dynasties and wars.

Overlords who are under the protection of the conquered lands, and his heirs from the royal lineage can be appointed as administrators. By strengthening one of the heirs, it can be ensured that he becomes more assertive in the struggle for the throne, while with the balance of the forces, each heir may be more likely to fight for the throne. As a result of the ruler's mismanagement, the overlords can rebel and act independently, while the rulers can silently assassinate their disloyal overlords. The great events of the time for the middle ages are given as war targets in the game. For example; The Pope could organize crusades as a very effective force, while the Vikings could continue their raids. Seljuks can start their western conquests by opening the gates of Anatolia.

In addition to showing the dynamics of the great wars in the middle ages, Crusader Kings offers students the opportunity to act in the conditions of that time, to think for the leaders of the period, and to develop their managerial skills by coping with the general problems of the age.



Figure 3. Crusader Kings III

3.4. Victoria

The Victorian series is a strategy game between 1836 and 1936, released by Paradox Interactive. The last product of the series Victoria II was launched in 2010. Victoria III is under development as of 2021 as seen in **Figure 4**.

Game; focuses on the industrial revolution, the technological developments of the period, colonialism, expansionism and the First World War. It is possible to see the colonial races of the countries that were the superpowers of the time in the industrialization period, and the period when imperialism and expansionism reached their peak in many respects. The game contains many technological developments chronologically. Technological developments start from the period when the foundations of the Industrial World were laid. It contains steam turbines, chemical industry, railways and many more details.

Victorian series; Students will learn how the process of the industrial revolution worked, how countries passed from colonialism to colonialism, the dynamics of the First World War, the world trade order in the 20th century, the processes and echoes of cultural and social developments, how the renewal stages of land and naval forces in the military took place and many events in the period. enable them to reinforce their learning.



Figure 4. *Victoria III*

3.5. Total War

Total War is a Series that contains many different games in its content. It was developed on the political and diplomatic structure of historical periods, the management of military forces and cities as seen in **Figure 5**.

Shogun: Total War, the first game in the series, was released in 2000. The last game, Total War Saga: Troy, takes place in the region within the borders of today's Turkey (Western Anatolia) and Greece, set in Ancient Greek times, and was released in 2020.



Figure 5. *Total War: Attila*

Total War (**Figure 6**); It offers the chance to command the field battles, the siege of castles and cities, as well as the defense of them, in three dimensions, as a general. While you can manage armies and troops, desired war tactics and strategies can be applied in the squares. The abilities, advantages and disadvantages of the units have been mathematically reflected in the game and it has been made possible for the battles to reach the result as a result of the moves of the users.

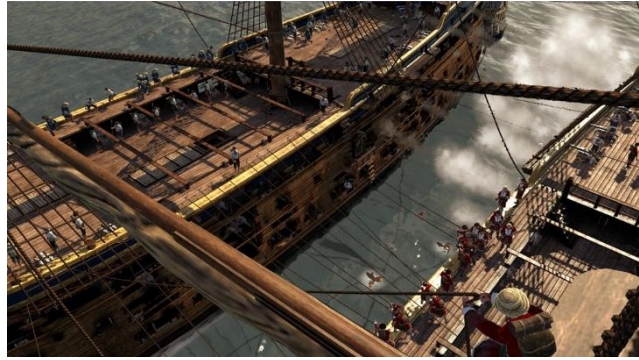

Figure 6. *Total War: Empire*

Although each game in the series reflects a different period, the most basic feature of the game is based on constantly defeating the enemies and conquering their lands. Serie; treasury management focuses on the use of resources and production, but each game's own dynamics may differ from the others.

With Total War games, students can provide details about how the wars take place on the squares, the discipline of the armies, the morale of the soldiers, the training of the troops and many more. They can also experience how the wars that the teachers describe in the lesson or read in the books take place, and they can even develop their analysis skills by trying different strategies in different conditions (**Figure 7**).



Figure 7. *Total War: Attila*

3.6. Civilization

Sid Meier's Civilization VI is a Strategy game developed by Firaxis Games. It is being released in 2016, and many new content has been added to the game with additional expansion packs as seen in **Figure 8**.

Civilization series, which is from the "4X" category of strategy games; It has game mechanics created by blending the terms "eXplore(explore), eXpand(spread), eXploit(exploit) and finally eXterminate(destroy)". Players first explore the dark areas on their maps, spread out into empty areas and destroy their enemies by exploiting those areas.

In Civilization, the player takes control of a civilization on randomly generated maps across a wide spectrum from prehistoric times to the future. There are different types of winning the game in the game, these can be achieved by in-game research, exploration, diplomatic moves, expansions, economic developments, administration and military conquests according to these winning types. Civilization is a turn-based strategy game. It gives each nation the right to make moves in turn. After the player makes his own actions, the turn passes to the other nation. When each nation completes its turn, the round is completed and they have the opportunity to move on to the next round. In the early ages, each round was equal to 50 years, while as the ages progress, each round corresponds to one year.

Players through ministries referred to as Advisors; they can adjust their military situation, scientific research situation, form of government and foreign policy. Cities produce various military and civil units. In addition, all kinds of buildings are built in cities. While buildings bring new features to cities, historical structures known as Wonders bring new features and powers across the country and provide superiority over competitors in various fields. The same is true for scientific research. There is an advanced diplomacy opportunity in the game, interstate relations, trade, technology and city exchange, war and peace agreements are made from the diplomacy screen that opens after clicking on the name of a country leader [12].



Figure 8. *Civilization VI*

4. Conclusion and Recommendations

In researches on the use of history-themed computer games; by using these games as materials in the teaching process of history lessons, it has been proven that students are able to assimilate the connection between historical thinking skills, the functioning of chronological processes, and enable the development of their cognitive abilities. In order for the use of such computer games in lessons to be beneficial, teachers should test the computer games themselves; it enables them to realize the incomplete, wrong aspects of the games and the aspects that are not suitable for the developmental periods of the students or the target acquisitions of the course, and to apply for solutions. The aforementioned adverse situation reveals that teachers' use of computer games in their lessons and adapting the games to the lessons require a detailed preliminary preparation process.

Today, with the development of technology, the inclusion of computer games in curricula other than entertainment purposes increases the motivation and interest of students in learning by concentrating their attention, and the content of computer games attracts attention. The fact that visual and effects increase the learning speed with the educational information given in the games, serving the target acquisitions, which is the aim of the curriculum, in which meaningful learning occurs, has revealed the importance of computer games in terms of using them in the education process [10].

According to another application, students at the seventh grade level of primary education were divided into two groups. While the students in one group received education with narrative-based methods, the students in the other group received their education in the game environment. At the end of the two-week process, the game-based learning environment; it has been revealed that students like it, reduce their anxiety, help them learn individually, and visually support learning [11].

The contributions of the games and their derivatives mentioned in the article to the students are obvious. Presenting such games as material to students and continuing their learning by experience will be much more beneficial for them individually. In addition, the inclusion of history-themed strategic computer games as a supporting material in history teaching processes is now a necessity to go beyond the limits of traditional education. As seen in the studies mentioned above, this situation will have a positive effect on students in terms of cognitive, sensory and psychological aspects and will increase the success coefficients of the students.

References

- [1] Malta S., 2010, İlköğretimde Kullanılan Eğitsel Bilgisayar Oyunlarının Öğrencilerin Akademik Başarılarına Etkisi
- [2] İçli G., Eğitim İstihdam ve Teknoloji, Pamukkale Üniversitesi Eğitim Fakültesi Dergisi Yıl:2001 Sayı:9
- [3] İnal Y., Kiraz E., Bilgisayar Oyunları İdeoloji İçerir mi Eğitsel ve Ticari Oyunlara Bakış, Türk Eğitim Bilimleri Dergisi Yaz 2008, 6(3), 523-544
- [4] Squire, K.D. (2004). Replaying history: Learning world history through playing Civilization III. Doctoral Dissertation, Indiana University: Indiana.
- [5] Denizel D., Sanatın Yeni Evresi Olarak Bilgisayar Oyunları, FLSF (Felsefe ve Sosyal Bilimler Dergisi), 2012 Bahar, sayı: 13, s. 107-143
- [6] Kaya A.,2013, Tokat, Çevrimiçi Oyun Bağımlılığı Ölçeğinin Geliştirilmesi: Geçerlik ve Güvenirlik Çalışması
- [7] Kablan Z., Cop M., Türkiye'de Eğitsel Oyunlarla İlgili Yapılmış Çalışmaların Analizi, Kocaeli Üniversitesi Eğitim Dergisi, 1/1 2018
- [8] Altınbulak D., Emir S., Avcı C. Sosyal Bilgiler Öğretiminde Eğitsel Oyunların Erişişe Ve Kalıcılığa Etkisi, Hasan Ali Yücel Eğitim Fakültesi Dergisi Sayı 2 (2006), 35-51
- [9] Gardner H., Multiple Intelligences: The Theory in Practice. New York: Basic Books. (1993).
- [10] Doğusoy B., İnal Y., Çok Kullanıcı Bilgisayar Oyunları ile Öğrenme, Mersin Üniversitesi (2006)
- [11] Bayırtepe E., Tüzün H., Oyun-Tabanlı Öğrenme Ortamlarının Öğrencilerin Bilgisayar Dersindeki Başarıları Ve Öz-Yeterlik Algıları Üzerine Etkileri, Hacettepe Üniversitesi Eğitim Fakültesi Dergisi (H. U. Journal of Education) 33: 41-54 (2007).
- [12] https://tr.wikipedia.org/wiki/Civilization_V (29.05.2021)

Meta-heuristic algorithm-based optimal PID controller design for Power Converters

Cihan Demircan ^{1,*}, Onur Vahip Güler ², Ali Keçebaş ³

¹ Department of Energy Systems Engineering, Graduate School of Natural and Applied Sciences, Süleyman Demirel University, 32260 Isparta, Turkey; <https://orcid.org/0000-0003-2094-0473>

² Department of Energy Systems Engineering, Faculty of Technology, Muğla Sıtkı Koçman University, 48000 Muğla, Turkey; <https://orcid.org/0000-0002-0910-1743>

³ Department of Energy Systems Engineering, Faculty of Technology, Muğla Sıtkı Koçman University, 48000 Muğla, Turkey; <http://orcid.org/0000-0003-4809-2461>

Abstract

The DC-DC converters are one of the important components of the renewable energy systems. In this study, meta-heuristic-based intelligent control schemes are applied, such as, proportional-integrator (PI), proportional-derivative (PD) and proportional-integrator-derivative (PID) control. The gain parameters of the PID controlled DC-DC buck or step-down converter is optimized with the artificial bee colony (ABC) algorithm. The obtained results indicate that PID control is better than the others together with proportional, integrator and derivative gain parameters 3.7560, 1.5947 and 3.6623, respectively.

Keywords: Buck Converter; PID Control; Artificial Bee Colony.

1. Introduction

Linear programming, gradient descent methods etc. conventional optimization techniques have some failures in solving complex problems. When the intelligent optimization compared with algorithms traditional methods, these have more advantages in solving continuous/discrete, multimodal and non-differentiable problems. In recent years, intelligent optimization algorithms have become more and more popular optimization tools [1].

The step-down or buck converters are widely used in applications, such as photovoltaic, energy storage systems, mobile power supply, DC power supply system, etc. In the design and implementation conveniences, the linear control strategies like PID control methods still by far play an important role [2-4]. The use of a control unit in DC-DC converters is a requirement to operate at the desired output voltage or current. The switching equipment of DC-DC converters is driven by a certain duty conversion. In the driver circuit, pulse width modulation (PWM) is controlled by the control unit for the reference value of output. Duty cycle of DC-DC converter is depended on PWM control scheme. So, output voltage or current is adjusted by duty cycle control technique.

The buck converter provides the constant output voltage under the variable load current and irregular input voltage [5]. Different controllers are used to eliminate the overshoot of output voltage and reduce the response time of the converter. PID controller is commonly used in industrial applications and has linear control method. Linear PID and Fuzzy Logic (FL) controller is implemented [6]. Sonmez et al. [7] optimized a buck converter's performance using the artificial bee colony (ABC) algorithm for only output voltage. Furthermore, the ABC was compared with the genetic algorithm (GA). The results showed that the ABC was better than the GA. Hekimoğlu and Ekinci [8] designed and compared optimal PID control system for step down converter using Whale Optimization Algorithm (WOA), Simulated Annealing (SA) and hybrid (WOASA) algorithm. According to obtained results; hybrid WOASA algorithm is better than WOA and SA algorithm. Sucu et al.[9] investigated of buck converter using digital PI controller-based implementation. Çimen et al. [10] presented chaotic flower pollination algorithm (CFPA)-based optimal PID controller design for buck converter. When the proposed algorithm is compared with firefly algorithm (FA) and whale optimization algorithm, obtained results shows that this algorithm is better than the other algorithms.

ABC algorithm takes an example of the modeling the food search behavior of bees. In literature, ABC-based optimal PID controller design is applied such as, train traction control [11], robot arm control [12], voltage and frequency control [13], continuous stirred tank reactor [14], position synchronization of dual linear motors [15], automatic generation control for interconnected reheat thermal power system [16] and DC motor [17]. Finally, engineering applications of ABC, modified-ABC and hybrid-ABC algorithms are reviewed [18].

In this study, the PI, PD and PID gain parameters of the converter are optimized using the ABC algorithm for the voltage fluctuations reduction. This study focuses on the improvement of dynamic behavior of the buck

*Corresponding author

E-mail address: cihandemircan48@gmail.com

converter using the ABC algorithm. In addition, PI, PD and PID controller's gain parameters are optimized and compared.

2. Materials and Methods

In this study, firstly, step down or buck converter mathematically modeled. And then, PI, PD and PID gain parameters of the buck converter are optimized for optimal PID controller design. ABC algorithm is selected for optimal controller design of DC-DC converter. In this section, informations about DC-DC converter, PID control and ABC algorithm are presented above.

2.1. DC-DC Buck Converter

A buck converter circuit is shown in Fig 1. This circuit operates in two modes. Here, inductor current flows on inductor L, capacitor C, and load resistance R in Mod1 (S switch is closed). In Mod2 (S switch is off), inductor current starts to decrease, and thus it flows on the capacitor C, load resistance L and diode D. The buck converter parameters used in this study are given in Table 1.

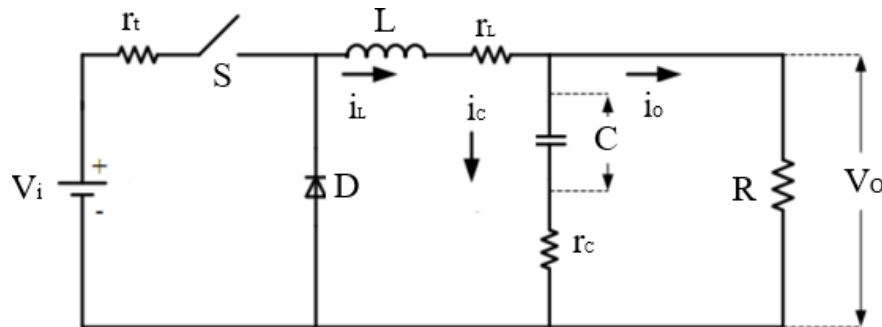

Figure 1. Buck converter circuit diagram.

Table 1. The significant parameters of the buck converter

Parameters	Value
Input Voltage (V_i)	35 V
Filter Coil	L-420 μ H, $r_L=0.7 \Omega$
Filter Capacitor	C-1450 μ F, $r_C=1.18 \Omega$
Switching Frequency (f_s)	100 kHz
Resistance of Switch (r_t)	0.2 Ω
Resistance of Diode (r_d)	0.7 Ω
Load Resistance (R)	118 Ω

Buck converter is step down chopper which converts unregulated DC to regulated DC. The chopper is operated by turning the switch (S) on/off at a high switching frequency switch is controlled by a pulse-width modulator (PWM) and it is turned on/off at a switching frequency (f_s) and duty cycle (D) and their relationship is given in Eq. (1) [19]. Thus, output voltage (V_o) is obtained by multiplying the input voltage (V_i) and duty cycle (D). In other words, V_o is determined by duty cycle as:

$$D = f_s t_{on} = \frac{t_{on}}{T} = \frac{t_{on}}{t_{on} + t_{off}} \quad (1)$$

where t_{on} is the time interval when the S is on/closed and t_{off} is the time interval when the S is off/open. Buck converter can be modeled by extracting of input/output voltage equations based on Kirchoff's voltage law. Diode is assumed as an ideal component. And then, voltage-current equations are written according to on and off cases of switch, considering resistance of semiconductor switch device [20], as expressed by:

$$L \frac{di_L(t)}{dt} = V_i(t) - [r_t + r_L]i_L(t) - V_o(t) \quad (2)$$

$$i_c(t) = i_L(t) - i_o(t) \quad (3)$$

$$C \frac{dv_c(t)}{t} = i_L(t) - \frac{V_o(t)}{R} \quad (4)$$

$$V_o = r_c i_c(t) + v_c(t) \quad (5)$$

The mathematical modeling of the buck converter is above. In this model, switch of the converter is driven by PID controller. So, duty cycle of the buck converter is controlled for regulate voltage. The PID controller is composed of a combination of Proportional (P), Integral (I) and Derivative (D) controllers. Therefore, it is called three term controller. It has got simple structure, good performance and wide range of applications, so it has been popular in the academic and industrial sectors. While it is designing, firstly control parameter is

determined. The expression of parallel PID controller is given as follow;

$$u(t) = K_p e(t) + K_i \int_0^t e(t) dt + K_d \frac{de(t)}{dt} \quad (6)$$

where $e(t)$ shows the difference between reference and actual values, $u(t)$ denotes the control signal. The K_p , K_i and K_d express respectively proportional, integral and derivative gain parameters of controller. The rise time is reduced by K_p gain parameter. Overshoot and setting time are decreased by the value of K_d . The steady-state error is eliminated by K_i . The performance of the PID controller depends on the accuracy of its parameters. So, the controller gain parameters need to be adjusted to appropriate values [21].

An integral Time Absolute Error (ITAE) criterion is used in the optimization process done by the ABC algorithm. While the effect of error which occurred in beginning on the total errors is low in terms of ITAE criteria, it increases depend on time. These errors are too high at continuous oscillation systems. Here, ITAE expression is seen in Eq. (7).

$$ITAE = \sum |te(t)| \quad (7)$$

In this study, the buck converter is mathematically modeled for optimization process. Then suitable PID gain parameter values are obtained by the artificial bee colony (ABC) algorithm. The optimization process of the buck converter is illustrated in Fig. 2. In this process, PID parameters are determined by ABC algorithm. In this way, PWM control unit is controlled and switch of the power converter is driven. Thus, dynamic behavior of the converter is investigated to reference and instant output voltages' differences. So, meta-heuristic algorithm-based optimal PID controller is designed.

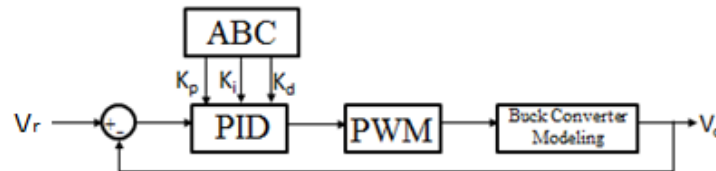

Figure 2. The optimal PID control process of the buck converter.

2.2. Artificial Bee Colony Algorithm

ABC algorithm was proposed by Karaboga [22]. Its performance was examined and compared with other optimization algorithms such as GA and Particle Swarm Optimization (PSO). These general results showed that ABC algorithm has better than other algorithms [23].

In the ABC algorithm, each cycle of the search take places three steps. Firstly; sending the employed bees onto the food sources and then measuring their nectar amounts are primary step. Secondly; selecting of the food sources by the onlookers after sharing the information of employed bees and determining the nectar amount of the foods processes are second step. And finally third step is determining the scout bees and then sending them onto possible food sources. The position of a food source indicates available solution of the optimization problem and the nectar amount of a food source fits to the quality (fitness) of the related solution. The number of the employed or the onlooker bees is same with the number of solutions in the population [24]. Analogously, in the optimization context, the position of a food source represents a candidate solution of the optimization problem and the nectar amount of a food source corresponds to the quality (fitness) of the associated solution. Detailed information about ABC algorithm is available in the literature [25-26]. Selected ABC parameter values to optimize the buck converter are given in Table 2.

Table 2. The selected data values about the ABC algorithm

ABC parameters	Value
Colony Size	50
Maximum Cycle	200
Parameter Intervals	0-4
Limit	100
Runtime	1

3. Results and Discussion

In this study, buck converter is mathematically modeled for optimal PID controller design. Best PID parameters are determined based on mathematical modeling using the meta-heuristic ABC algorithm. Obtained results are given and discussed below.

Step-down or buck converters decrease the output voltages. So, output voltage is lower than input voltages. Output voltage or current of the power converter is adjusted by PWM-based duty cycle ratio control unit. Thus, regulated output voltage or current is supplied to power load.

In the scope of this study, input and output voltages are selected as 35 V and 12 V, respectively. PI, PD and PID based PWM control studies are done for optimal constant output voltage control. Obtained optimal PI, PD and PID gain parameters are given in Table 3. As seen this table, K_P is over than 3 for all controllers. Integrator gain parameter (K_i) is 3.2011 also for PI controller. However, this parameter is very small for PID controller and its value is 1.5947. K_i parameter changing is half-and-half. However, derivative gain parameter (K_d) is near to limited value. Time-dependent absolute error (ITAE) and output voltage variation of these controllers are given in Table 3 and Figure 3, respectively. Obtained results show that PID control is better than PI and PD controllers. Output voltage variations and ITAE is lower than other controller. While the ITAE value of PID controller is 0.0125, it is 0.0164 and 0.0173 for PI and PD controllers. So, optimal control of the power converter is carried out. Meta-heuristic algorithm is helpful for optimal control of the power electronic control unit.

Table 3 Optimal PID controller gain parameter results

Controller	K_p	K_i	K_d	ITAE
PI	3.8287	3.2011	-	0.0164
PD	3.2589	-	0.5079	0.0173
PID	3.7560	1.5947	3.6623	0.0125

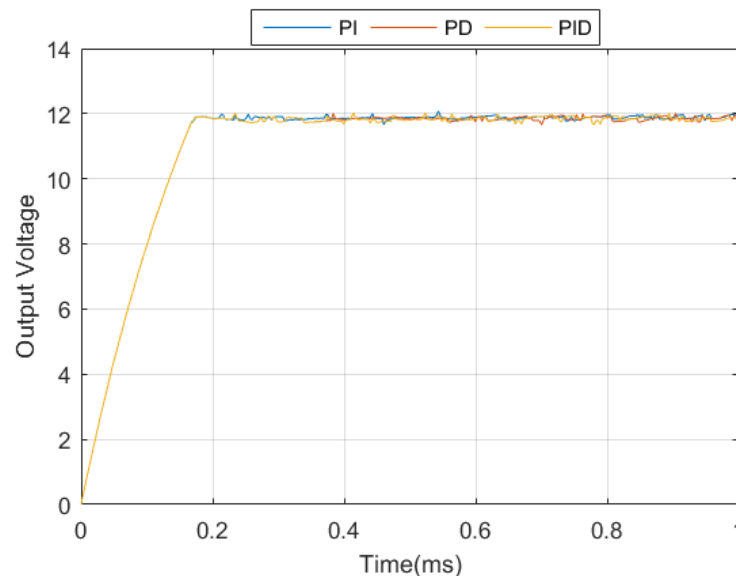

Figure 3. Output voltage variations for optimal PID control of buck converter

4. Conclusions

In this study, optimal gain parameter of PI, PD and PID controllers were investigated for step-down converter using meta-heuristic algorithm. Step-down converter was modeled and controlled by PID controller for regulated output voltages. Meta-heuristic process was done in order to decrease the output voltage variations. According to obtained results; PID controller is better than PI and PD controllers. Its time dependent error is more lees. So, optimal PID control of the buck convert was carried out. Meta-heuristic ABC algorithm is proposed for optimal control of power electronic circuit and engineering problems.

Nomenclature

Abbreviations

ABC	artificial bee colony
CFPA	chaos flower pollination algorithm
FA	firefly algorithm
FL	fuzzy logic
GA	genetic algorithm
PID	proportional, integral, derivative
PWM	pulse width modulation
SA	simulated annealing algorithm
WOA	whale optimization algorithm

References

- [1] Xiao S., Wang H., Wang W., Huang Z., Zhou X., Xu M. "Artificial bee colony algorithm based on adaptive neighborhood search and Gaussian perturbation", *Applied Soft Computing Journal* 100 (2021) 106955, doi: 10.1016/j.asoc.2020.106955.
- [2] Ma L., Zhang Y., Yang X., Ding S., Dong L. "Quasi-Continuous Second-Order Sliding Mode Control of Buck Converter", *IEEE Access* 6(2018) 17859-17867, doi: 10.1109/ACCESS.2018.2795027.
- [3] Yang J, Wu B., Li S., Yu X. "Design and qualitative robustness analysis of an DOBC approach for DC-DC buck converters with unmatched circuit parameter perturbations", *IEEE Trans. Circuits Syst. I, Reg. Papers* 63(4) (2016), 551-560, doi: 10.1109/TCSI.2016.2529238.
- [4] Ding S., Zheng W., Sun J., Wang J. "Second-order sliding mode controller design and its implementation for buck converters", *IEEE Trans. Ind. Informatics* 14,(5) (2018),1990-2000, doi: 10.1109/TII.2017.2758263.
- [5] Yuan Y., Chang C., Zhou Z., Huang X., Xu Y. "Design of a Single-Input Fuzzy PID controller based on genetic optimization scheme for DC-DC buck converter", *International Symposium on Next-Generation Electronics (ISNE)*, 4-6 May 2015, Taipei, (2015) 1-4, doi: 10.1109/ISNE.2015.7131965.
- [6] Shyama M., Swaminathan P. "Digital linear and nonlinear controllers for buck converter", *International Journal of Soft Computing and Engineering* 2(1) (2012) 336-342, Retrieval Number: A0447022112/2012©BEIESP.
- [7] Sonmez Y., Ayyıldız O., Kahraman H.T., Guvenc U., Duman S. "Improvement of buck converter performance using Artificial Bee Colony optimized-PID controller", *Journal of Automation and Control Engineering* 3(4), (2015) 304-310, doi: 10.12720/joace.3.4.304-310.
- [8] Hekimoğlu B., Ekinci S. "Optimally Designed PID Controller for a DC-DC Buck Converter via a Hybrid Whale Optimization Algorithm with Simulated Annealing", *Electrica* 20(1) (2020) 19-27, doi: 10.5152/electrica.2020.19034.
- [9] Sucu H., Goktas T., Arkan M. "Design, Simulation and Application of Buck Converter with Digital PI Controller", *Balkan Journal Of Electrical & Computer Engineering* 9(2) (2021) 106-112, doi: 10.17694/bajece.884290.
- [10] Çimen, M.E., Garip, Z.B., Boz, A.F. "Chaotic flower pollination algorithm based optimal PID controller design for a buck converter", *Analog Integrated Circuits and Signal Processing* 107(2021) 281–298, doi: 10.1007/s10470-020-01751-5.
- [11] Wang B., Yang, J., Jiao H.N., Zhu K., Chen Y.Q. "Design of auto disturbance rejection controller for train traction control system based on artificial bee colony algorithm", *Measurement*, 160(2020) 107812, doi: 10.1016/j.measurement.2020.107812.
- [12] Sultan. G.A., Jarjes M.K. "Optimal PID controller design using artificial bee colony algorithm for robot arm", *Indonesian Journal of Electrical Engineering and Computer Science* 21(1)(2021) 84-91, doi: 10.11591/ijeecs.v21.i1.pp84-91.
- [13] Ghosh A., Ray A.K., Nurujjaman Md., Jamshidi M. "Voltage and frequency control in conventional and PV integrated power systems by a particle swarm optimized Ziegler–Nichols based PID controller", *SN Applied Sciences*, 3(2021)314, doi: 10.1007/s42452-021-04327-8.
- [14] Goud H., Swarnkar P. "Investigations on Metaheuristic algorithm for designing adaptive PID controller for continuous stirred tank reactor", *MAPAN-Journal of Metrology Society of India* 34(1) (2019) 113–119, doi: 10.1007/s12647-018-00300-w.
- [15] Chen S.Y., Chen C.S., Yang Z.W. "Self-tuning cross-coupled two degree-of-freedom PID control for position synchronization of dual linear motors", *Applied Mathematical Modelling* 64(2018) 214–234, doi: 10.1016/j.apm.2018.07.020.
- [16] Gözde H., Taplamacioglu M.C., Kocaarslan İ. "Comparative performance analysis of Artificial Bee Colony algorithm in automatic generation control for interconnected reheat thermal power system", *Electrical Power and Energy Systems* 42 (2012) 167–178, doi: 10.1016/j.ijepes.2012.03.039.
- [17] El-Telbany M.E. "Tuning PID Controller for DC Motor: An Artificial Bees Optimization Approach", *International Journal of Computer Applications* 77(15) (2013) 18-21, doi: 10.5120/13559-1341.
- [18] Sharma A., Aharma A., Choudhary S., Pachauri R.K., Shrivastava A., Kumar D. "A Review on Artificial Bee Colony and it's Engineering Applications", *Journal of Critical Reviews* 7(11)(2020) 4097-4107, doi: 10.31838/jcr.07.11.558.
- [19] Kazmierczuk M. K. "Pulse-Width Modulated DC-DC power converters", John Wiley & Sons, UK, 2008.
- [20] Singh N.S., Khandelwal C.S. "Modelling and digitized discrete feedback loop with PID compensator for buck converter using MATLAB/Simulink", *International Conference on Power, Automation and Communication (INPAC)*, (2014) 55-59, 6-8 October 2014, Amravati, doi: 10.1109/INPAC.2014.6981135.
- [21] Altinoz O.T., Erdem H. "Evaluation Function Comparison of Particle Swarm Optimization for Buck Converter", *International Symposium on Power Electronics Electrical Drives Automation and Motion (SPEEDAM)*, (2010) 798-802, 4-16 June 2010, Pisa, doi: 10.1109/ICCCI.2012.6158919.
- [22] Karaboga, D. "An ideal based on honey bee swarm for numerical optimization", Technical Report – TR06, Erciyes University, Engineering Faculty, Computer Engineering Department, October 2005.
- [23] Karaboga D., Akay B. "A comparative study of artificial bee colony algorithm", *Applied Mathematics and*

Computation, 214(1) (2009) 108-132, doi:10.1016/j.amc.2009.03.090.

- [24] Karaboga D., Basturk B. "A powerful and efficient algorithm for numerical function optimization: artificial bee colony (ABC) algorithm", *Journal of Global Optimization*, 39(3) (2007) 459-471, doi: 10.1007/s10898-007-9149-x.
- [25] Demircan C., Bayrakçı H.C., Keçebaş A. "Machine Learning-based improvement of empiric models for an accurate estimating process of global solar radiation", *Sustainable Energy Technologies and Assessments*, 37(2020) 100574, doi: 10.1016/j.seta.2019.100574.
- [26] Özkaraça O., Keçebaş A., Demircan C. "Comparative thermodynamic evaluation of a geothermal power plant by using the advanced exergy and artificial bee colony methods", *Energy*, 156(2018) 169-180, doi: 10.1016/j.energy.2018.05.095

A Review on Deep Learning Models for Satellite Imagery

Hasan Ersan Yağcı^{1,*}, Abdullah Atçılı², Şükrü Sezer³.

¹ Artificial Intelligence Department, Mugla Sıtkı Kocman University; 0000-0001-7556-8811

² Artificial Intelligence Department, Mugla Sıtkı Kocman University; 0000-0001-6872-6754

³ College of Computing, Georgia Institute of Technology; 0000-0003-3045-2596

Abstract

Object detection and image classification from remote sensing data are used in many different fields. It has been the subject of many studies in recent years. Research in this field has increased with the development of deep learning techniques and remote sensing data, which can be satellite images or unmanned aerial vehicles (UAV), providing high resolution spatial and spectral data. In this review, we survey modern deep learning techniques are trained on remote sensing data. Term remote sensing data is widely used for satellite imagery, however the term also refers to UAV collected data. It is chosen as a topic of the this review that 'how green the metropolitans?'. There are two approaches for this question. First one is the detection of green (vegetation) in all metropolitan and the other one is classification of green types. Convolutional neural networks (CNN), generative adversarial networks (GAN), and autoencoder (AE) were compared on tensorflow's UC Merced dataset.

Keywords: *Deep Learning; Satellite Imagery; Remote Sensing.*

1. Introduction

It is important where we get the data needed. And most of the time, data collection method can and will determine the approach to the problem or data and which method will be used. Remote sensing of images are used in many area like land use land cover (LULC), urbanization, classification, vegetation, change detection [1]. The remote sensing data is used mainly for these problems. This study will cover calculation of green ratio and green classification of the metropolitans with modern deep learning techniques.

Remote sensing is the satellite views mainly. But use of UAV sensor data has recently increased with the development of as a remote sensing drone technology. UAV imagery cannot give the same performance compared to the satellite imagery. The area of coverage and the number the images cannot be compared to those provided by satellites.

There are different studies performed on UAV's remote sensing data. In this study [2], classify the vegetation of the urban according to healthy classes by the drone (UAV) images. Study is performed on aerial images which is taken from distance between 20 to 30 m, on sunny day. In [3], Unmanned Aerial Vehicle (UAV) is used to detect changes of urban areas. For the change detection different times UAV images are needed. In other study [4], UAV images are used to get cultivated land information. In this study [5], UAV images are used to classify vegetation in vegetated areas under clear sky conditions. This study claims that UAV offers considerable advantages with high-resolution capability but adds that UAV has limits on number of sensors that can be mounted.

UAV has some advantages, UAVs can be loaded with specialized sensors according to the purpose of the study. For example, for the vegetation the normalized difference vegetation index (NDVI) can be needed so the spectral resolution high sensors can be mounted. The UAVs can move/fly low height and gives high spatial resolution. However, UAV has some disadvantages too. The study area should be small. The UAV cost is high and needs more time to cover large areas. In addition, number of sensors carried at the same time is strictly limited to weight capacity of UAV. Weather conditions can also limit data collection operations with UAV and it is also challenging to collect data pertaining large areas such as a whole city at a time.

As mentioned above, the study area should be small. UAV imagery can be used for the agriculture, classify the trees in a forest or garden, for the urbanization of the county, for the solar panel's anomaly detection etc. however it is somewhat limited for large-scale data collection operations including over metropolitan areas.

Mostly in the articles, the term "remote sensing data" is used interchangeably with satellite imagery. It can be thought that you can give more details rather than satellite imagery. However the state of art satellite systems are the main source for the remote sensing work area.

There are three major remote sensing academic societies; [6] All of these societies use satellite imagery as the data source as mainly. The remote sensing data will covered in detail at the data section. The remote sensing term is used for the satellite imagery until end of article.

*Corresponding author

E-mail address: hersanyagci@gmail.com

As mentioned above, the satellites keep providing us with the remote sensing data of the Earth. Remote sensing of images are used in many area like classification and change detection. There is a big data, this data is the source of many studies. **Figure 1** [6]

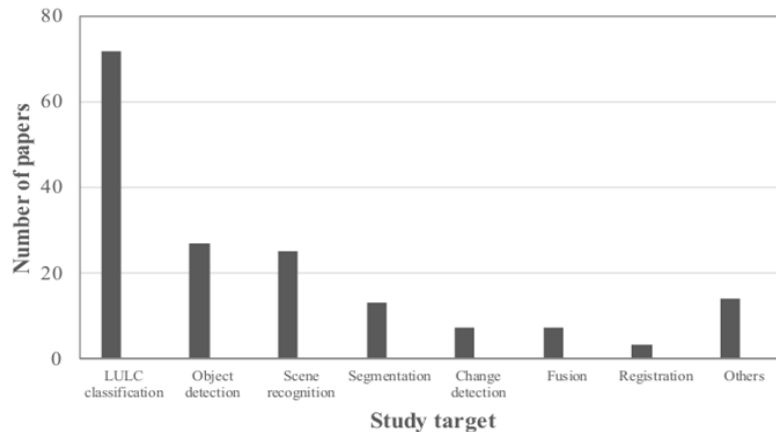

Figure 1. Remote sensing study targets.

2. Data

The remote sensing data used for mainly LULC, object detection, vegetation, scene recognition, classification, segmentation, change detection etc. All of these study target mainly use the spectral and spatial resolutions of remote sensing data. The first artificial satellite Sputnik-1 launched at 1957, after this year many satellites launched for different aims by different countries. At 1972 Landsat program has begun and The Earth Resources Technology Satellite is launched.

In 1986 The Spot can take 3D, At 1999 IKONOS first VHR (very high resolution) satellite. It can give 82 cm spatial resolution. At 2008 GeoEye-1 gives under the 50 cm spatial resolution, 2009 worldview-2 9 bant spectral VHR, at 2015 worldview-3 gives under 30 cm spatial VHR and 9 spectral band. With advancing technology, the data becomes more detailed and more precise. With this situation State of the art AI is obligatory. Because high spatial resolution and wide spectral resolution can be possible. There are 3 different orbit levels, as we investigate them, Low Earth Orbit (LEO), Geostationary Earth Orbit (GEO) and Medium Earth Orbit (MEO).

LEO provides high spatial resolution with low temporal resolution while GEO provides for low spatial resolution, but high temporal resolution. We need low orbit altitude to more spatial resolution, it is LEO. There is a two important point for the remote sensing spatial and spectral resolutions.

Resolution is the important issue for the remote sensing studies. The resolution of an image gives the possible detailed information provided by the imagery. In remote sensing, there are three types of resolution: spatial, spectral and temporal.

Spatial Resolution refers to the size of the smallest piece that can be detected by a satellite system or presented in a satellite image. It is given as a value symbolizing the length of one side of a square. For example, a spatial resolution of 30m means that one pixel represents an area 30 by 30 meters on the ground. [7] The display of low, medium and high spatial resolution objects **Figure 2** [8].

Spectral Resolution has to do with how a satellite sensor measures certain wavelengths of the electromagnetic spectrum. The finer the spectral resolution, the narrower the wavelength range for a particular channel or band [7].

Temporal resolution relates to the time among images. At our task, temporal resolution is not important, temporal differences are irrelevant as we do not expect to change the green ratio of a metropolitan over the course of minutes or days. We need constant image of the metropolitan we need high spatial and spectral resolution. We need LEO satellite imagery. The quality of the spatial and spectral resolution will define our approach (object based or pixel based) style.

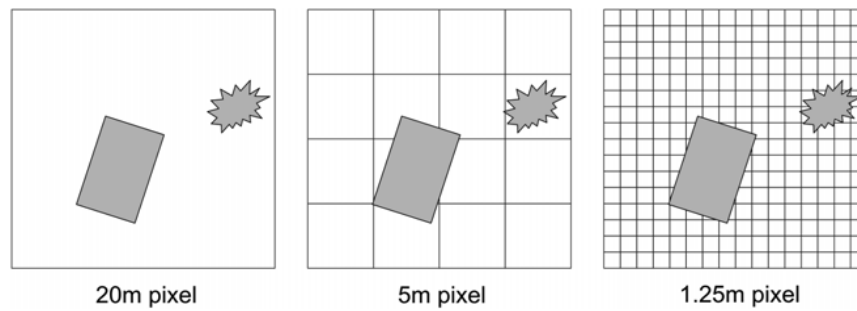

Figure 2. Comparison of spatial resolutions

In the comparison of methods have used the UC Merced dataset. UC Merced dataset has 100 images for each one of 21 classes. These are; agricultural, airplane, baseball diamond, beach, buildings, chaparral, dense residential, forest, freeway, golf course, harbor, intersection, medium residential, mobile home park, overpass, parking lot, river, runway, sparse residential, storage tanks, tennis court; **Figure 3.** Each image measures 256x256 pixels. The images were manually taken out from large images from the imagery collection for various urban areas around the country. The pixel resolution of this public domain imagery is 1 foot [9].



Figure 3. UC Merced dataset

3. Methods

There are two approaches for the remote sensing data; these are pixel based and object based. There are two aims; classify each green object and calculate the all green ratio. For the calculation of green ratio; best way is the unsupervised methods (clustering pixels). We can use unsupervised pixel based approach and detect green objects by the spectral resolution/bands. We can utilize some indexes evolved from spectral bands like NDVI. For the classification, we can use supervised methods, we need training data with labeled. We have to define spectral information for the each classes in the training data. We will define classes, forest, urban, lake Etc. and define spectral info. Each pixel will be interpreted numerically according to its spectral characteristics. We use some classification techniques to the define pixel's characteristics. Like; maximum likelihood classifier, minimum distance classifier. We can use object based classification method too for classification task. In this method, instead of pixel characteristics, we use segments.

Pixel-based classification methods analyze spectral properties of each pixel, whereas object based classification methods consider spectral, spatial and contextual information of segments [10]. An object-based approach deals with image segments, or "patches/objects of reality", rather than individual pixels [11].

In this study [11], pixel-based approach is used for to see change of the green area in the city, object-based approach is used to define the change as an expansion, shrinking, new or lost etc. by the size. Before the deep learning techniques, traditional pixel based methods were used mostly. Pixel based methods use spectral information. Object based methods use both spectral and spatial information. Object based approach use spectral characteristics and the class's shape, texture and their (neighbor pixel) spatial relationships. Pixel based classification is based solely on the spectral information in each pixel, object-based classification is based on information from a set of similar pixels called objects or image objects.

In object based approach; firstly, segmentation is done then the classification. Segmentation is the process

that pixel grouping according to spectral and spatial characteristics for the classes. Scale is the very important term for object based approach. Three methods were examined in this review. Under the following headings; the results of the articles that made classification by applying the CNN, GAN and AE using UC Merced dataset were examined.

3.1. Convolutional Neural Network (CNN)

Convolutional Neural Network (CNN) is the one of the most commonly used deep learning model and its originally designed to process data in the form of multiple arrays [12] CNN is well-suited for processing multiband remote-sensing image data. CNN consists four different types of hierarchical structures: convolutional layers, pooling layers, fully connected layers and softmax layer. The architecture of CNNs; **Figure 4** [13] At each layer, the input image is convolved with a set of K kernels $W = \{ W_1, W_2, \dots, W_K \}$ and added biases $b = \{ b_1, \dots, b_K \}$, each generating a new feature map X_k .

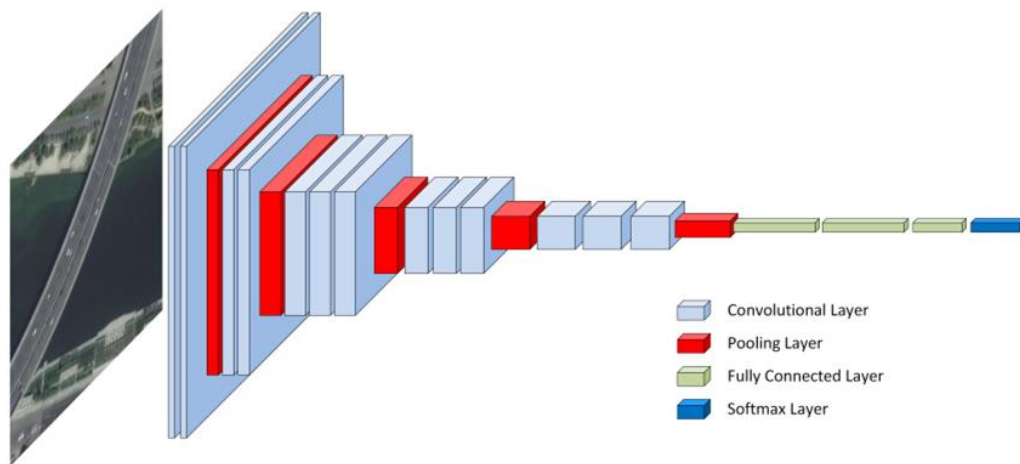

Figure 4. Architecture of CNN

There are a lot of articles to evaluate the different kinds of CNN networks. With GoogleNet, Xia et al. got 94.31 accuracy score. And with VGG-16 model, they got 95.21 accuracy score [14]. Zhang et al. used VGG-16-CapsNet and got 98.81 accuracy score **Table 1** [15].

Table 1. Results of CNN models.

CNN Model	Accuracy Score
GoogleNet	94.31
VGG-16 CapsNet	95.21

3.2. Generative Adversarial Networks (GANs)

Generative adversarial networks (GANs) [16] have become a very popular category of unsupervised deep learning models. GAN model has two sub-models. These are generative network and discriminative network; **Figure 5** [13].

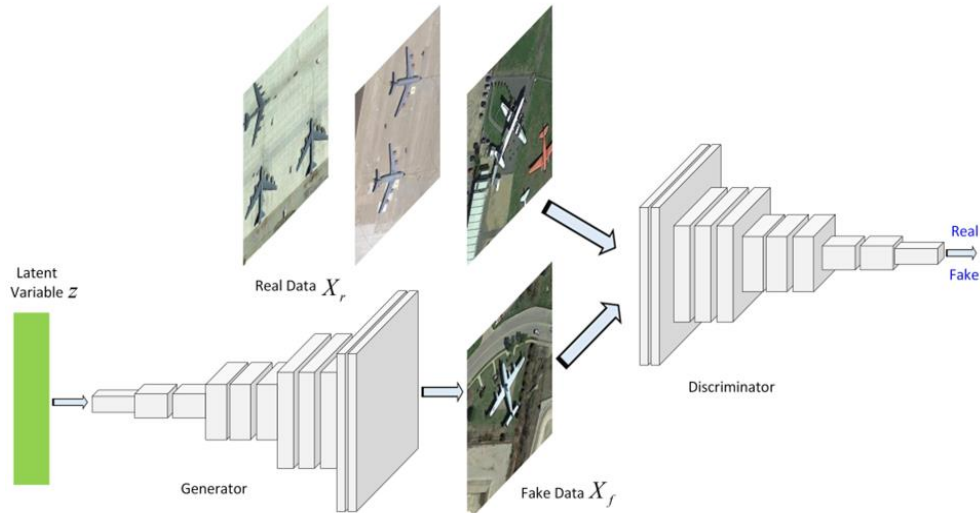

Figure 5. Architecture of GAN

Generally, the generative network is trained to generate samples that keep in line with real data in a manifold, whereas the discriminative network is trained to determine whether a sample is from real data or the generator. These two networks compete with each other so that the distribution captured from the generator is as similar as possible to the distribution of the real data. [17]

Reseachers have studied about GAN. There are several techniques applied to low-level computer vision tasks. According to the different kinds of model trainings, Lin et al. used MARTA GANs model and the got 94.86 accuracy score [18]. On the orther hand, Yu et al. used Attention GANs model and got 97.69 accuracy score in **Table 2** [19].

Table 2. Results of GAN models.

GAN Model	Accuracy Score
MARTA GANs	94.68
Attention GANs	97.69

3.3. Autoencoder (AE)

Autoencoder is one of the most popular models in deep learning which an unsupervised learning model is. It consists of symmetrical neural network and consists of input layer, hidden layer, and output layer. Autoencoder contains encoder and decoder. Encoding part is the reduction in the number of nodes at our hidden layers until bottleneck. And decoding part is the increasing in the number of nodes at our hidden layers after bottleneck. The architectures of (a) autoencoder and (b) stacked autoencoder; **Figure 6** [13].

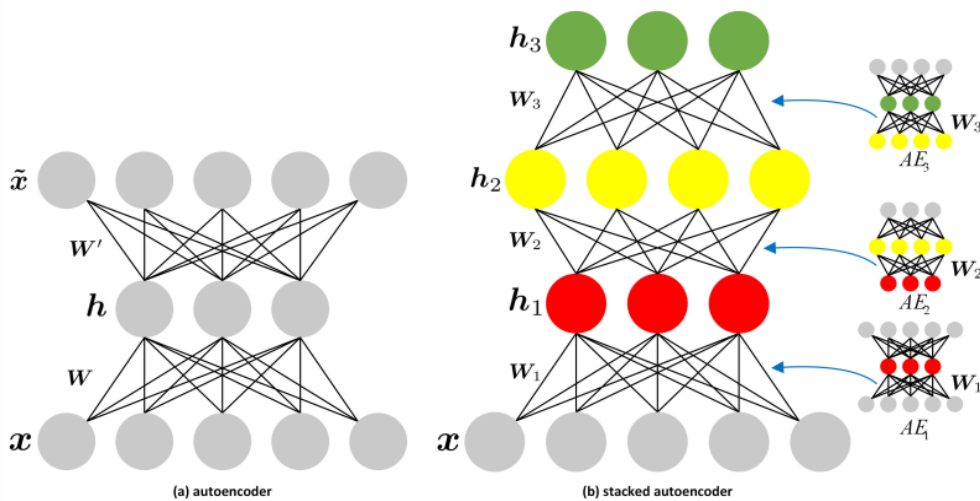

Figure 6. Architectures of AE and SAE

Autoencoder is also widely used in remote-sensing. There are some researches and their scores about autoencoders. Zhang et al. run Saliency-guided unsupervised feature learning (SGUFL) and they got 82.72 accuracy score. [20] Xiong et al. run Stacked convolutional denoising auto-encoders (SCDAE) model and they got 93.7 accuracy score. **Table 3** [21]

Table 3. Results of AE models

AE Model	Accuracy Score
SGUFL	82.72
SCDAE (Stacked)	93.7

4. Results

This review aims that to gather methods and approach styles to the ‘how green the metropolitans?’ task. The importance of the data set to be used and the studies using drone imagery as remote sensing instead of satellite imagery were mentioned. In line with the information provided by the satellites, 2 basic approaches (pixel and object based) were investigated. The articles in which 3 methods as CNN, GAN and AE were used on the UC Merced dataset were reviewed. As a result of the studies examined, the accuracy score success is shown below; **Table 4**. The best success has been achieved with GAN. However, the most used method in remote sensing data is CNN. [6]

Table 4. Results of models

Method	Accuracy Score
Attention GANs	97.69
VGG-16 CapsNet (CNN)	95.21
MARTA GANs	94.68
GoogleNet (CNN)	94.31
SCDAE (Stacked AE)	93.7
SGUFL (AE)	82.72

This review can be carried forward by using high-resolution satellite images of a particular metropolitan area as data and choosing the appropriate approach mentioned above, measuring both the green ratio and green classification of metropolitans.

References

- [1] Lei Ma, Yu Liu, Xueliang Zhang, Yuanxin Ye, Gaofei Yin, Brian Alan Johnson, Deep learning in remote sensing applications: A meta-analysis and review, ISPRS Journal of Photogrammetry and Remote Sensing, Volume 152, 2019, Pages 166-177.
- [2] Moreno-Armendáriz, M.A.; Calvo, H.; Duchanoy, C.A.; López-Juárez, A.P.; Vargas-Monroy, I.A.; Suarez-Castañón, M.S. Deep Green Diagnostics: Urban Green Space Analysis Using Deep Learning and Drone Images. *Sensors* 2019, 19, 5287.
- [3] Qin, R. An Object-Based Hierarchical Method for Change Detection Using Unmanned Aerial Vehicle Images. *Remote Sens.* 2014, 6, 7911-7932.
- [4] Lu, H., Fu, X., Liu, C. et al. Cultivated land information extraction in UAV imagery based on deep convolutional neural network and transfer learning. *J. Mt. Sci.* 14, 731–741 (2017).
- [5] Tetsuro Ishida, Junichi Kurihara, Fra Angelico Viray, Shiello Baes Namuco, Enrico C. Paringit, Gay Jane Perez, Yukihiro Takahashi, Joel Joseph Marciano, A novel approach for vegetation classification using UAV-based hyperspectral imaging, *Computers and Electronics in Agriculture*, Volume 144, 2018, Pages 80-85.
- [6] Lei Ma, Yu Liu, Xueliang Zhang, Yuanxin Ye, Gaofei Yin, Brian Alan Johnson, Deep learning in remote sensing applications: A meta-analysis and review, ISPRS Journal of Photogrammetry and Remote Sensing, Volume 152, 2019, Pages 166-177, ISSN 0924-2716.
- [7] Satellite Applications for Geoscience Education.
- [8] T. Blaschke, Object based image analysis for remote sensing, ISPRS Journal of Photogrammetry and Remote Sensing, Volume 65, Issue 1, 2010, Pages 2-16, ISSN 0924-2716.
- [9] Yi Yang and Shawn Newsam, "Bag-Of-Visual-Words and Spatial Extensions for Land-Use Classification," ACM SIGSPATIAL International Conference on Advances in Geographic Information Systems (ACM GIS), 2010.
- [10] Elif Sertel & Ugur Alganci (2015): Comparison of pixel and object-based classification for burned area mapping

using SPOT-6 images, *Geomatics, Natural Hazards and Risk*.

- [11] Jing Wang, Weiqi Zhou, Yuguo Qian, Weifeng Li, Lijian Han, Quantifying and characterizing the dynamics of urban greenspace at the patch level: A new approach using object-based image analysis, *Remote Sensing of Environment*, Volume 204, 2018, Pages 94-108.
- [12] LeCun, Y., Bengio, Y., Hinton, G., 2015. Deep learning. *Nature* 521 (7553), 436–444.
- [13] G. Cheng, X. Xie, J. Han, L. Guo and G. -S. Xia, "Remote Sensing Image Scene Classification Meets Deep Learning: Challenges, Methods, Benchmarks, and Opportunities," in *IEEE Journal of Selected Topics in Applied Earth Observations and Remote Sensing*, vol. 13, pp. 3735-3756, 2020.
- [14] Xia, G.S.; Hu, J.; Hu, F.; Shi, B.; Bai, X.; Zhong, Y.; Zhang, L.; Lu, X. AID: A benchmark data set for performance evaluation of aerial scene classification. *IEEE Trans. Geosci. Remote Sens.* 2017, 55, 3965–3981.
- [15] Wei Zhang 1,2, Ping Tang 1 and Lijun Zhao 1, Remote Sensing Image Scene Classification CNN-CapsNet, *Remote Sens.* 2019, 11, 494; doi:10.3390/rs11050494.
- [16] Goodfellow, I., Abadie, J., Mirza, M., Xu, B., Farley, D., Ozair, S., Courville, A., Bengio, Y., 2014. Generative adversarial nets, arXiv: 1406.2661v1.
- [17] K. Jiang, Z. Wang, P. Yi, G. Wang, T. Lu and J. Jiang, "Edge-Enhanced GAN for Remote Sensing Image Superresolution," in *IEEE Transactions on Geoscience and Remote Sensing*, vol. 57, no. 8, pp. 5799–5812, Aug. 2019, doi: 10.1109/TGRS.2019.2902431.
- [18] D. Lin, K. Fu, Y. Wang, G. Xu, and X. Sun, "Marta gans: Unsupervised representation learning for remote sensing image classification," *IEEE Geoscience and Remote Sensing Letters*, vol. 14, no. 11, pp. 2092– 2096, 2017.
- [19] Y. Yu, X. Li, and F. Liu, "Attention gans: Unsupervised deep feature learning for aerial scene classification," *IEEE Transactions on Geoscience and Remote Sensing*, vol. 58, no. 1, pp. 519–531, 2019.
- [20] F. Zhang, B. Du, and L. Zhang, "Saliency-guided unsupervised feature learning for scene classification," *IEEE Transactions on Geoscience and Remote Sensing*, vol. 53, no. 4, pp. 2175–2184, 2014.
- [21] B. Du, W. Xiong, J. Wu, L. Zhang, L. Zhang, and D. Tao, "Stacked convolutional denoising auto-encoders for feature representation," *IEEE transactions on cybernetics*, vol. 47, no. 4, pp. 1017–1027, 2016.