

# Researcher

CILT/VOL **02**

SAYI/ISSUE **02**

YIL/YEAR **2022**

# Researcher

CİLT/VOL 02

SAYI/ISSUE 02

YIL/YEAR 2022

## Sahibi / Owner

Ankara Bilim Üniversitesi / Ankara Science University

## İmtiyaz Sahibi / Licensee

Prof. Dr. Yavuz DEMİR (Ankara Science University)

## Baş Editör / Editor in Chief

Assoc. Prof. Dr. Hakan ÇAĞLAR (Ankara Science University)

## Editör / Editor

Asst. Prof. Dr. Yavuz Selim ÖZDEMİR (Ankara Science University)

## Alan Editörleri / Section Editors

Assoc. Prof. Dr. Oğuzhan Ahmet ARIK (Nuh Naci Yazgan University)

Asst. Prof. Dr. Emir Hüseyin ÖZDER (Ankara Science University)

## Yayın Kurulu / Editorial Board

Prof. Dr. İsmail COŞKUN (Ankara Science University)

Prof. Dr. Halim Haldun GÖKTAŞ (Ankara Science University)

Prof. Dr. Cem Harun MEYDAN (Ankara Science University)

Assoc. Prof. Dr. Ender SEVİNÇ (Ankara Science University)

Assoc. Prof. Dr. Hakan ÇAĞLAR (Ankara Science University)

Assoc. Prof. Dr. Babek Erdebili (B.D. Rouyendegh) (Ankara Yıldırım Beyazıt University)

Assoc. Prof. Dr. Tansel DÖKEROĞLU (Çankaya University)

Asst. Prof. Dr. Yavuz Selim ÖZDEMİR (Ankara Science University)

Asst. Prof. Dr. Ercüment KARAPINAR (Ankara Science University)

Asst. Prof. Dr. Volkan ÇAKIR (Lebanese American University)

## Danışma Kurulu / Advisory Board

Prof. Dr. Yavuz DEMİR (Ankara Science University)

Prof. Dr. Beycan İBRAHİMOĞLU (Ankara Science University)

Prof. Dr. Ahmet COŞAR (Çankaya University)

Prof. Dr. Taner ALTUNOK (Konya Food and Agriculture University)

Prof. Dr. Abdullah AVEY (Süleyman Demirel University)

Prof. Dr. Ashraf M. ZENKOUR (King Abdul Aziz University)

Prof. Dr. Sci Nguyen Dinh DUC (Vietnam National University)

Prof. Dr. Mohammad SHARİYAT (K.N. Toosi University of Technology)

Prof. Dr. Mohammad Reza ESLAMÍ, (Amirkabir University of Technology)

Prof. Dr. Hui-Shen SHEN (Shanghai Jiao Tong University)

Prof. Dr.-Ing. Eckart SCHNACK (Karlsruhe Institute of Technology)

Assoc. Prof. Dr. Nicholas FANTUZZI (University Bologna)

## Dil Editörü / Language Editor

Asst. Prof. Dr. Azime PEKŞEN YAKAR (Ankara Science University)

## Sekretarya / Editorial Secretariat

Derya NURCAN (Ankara Science University)

e-ISSN:2717-9494

**Yayıncı / Publisher:** Ankara Bilim Üniversitesi / Ankara Science University

**Basım Tarihi / Date of Publication:** Aralık 2022/ December 2022

**Yayın Türü / Publication Type:** Uluslararası Süreli Yayın / International Periodical

**İletişim Bilgileri / Contact Information:** Çamlıca Mah.Anadolu Bulvarı No:16A/1 Yenimahalle Ankara

**Web Sitesi / Website:** <https://researcher.ankarabilim.edu.tr/>

**E-posta / E-mail:** [researcher@ankarabilim.edu.tr](mailto:researcher@ankarabilim.edu.tr)

Researcher uluslararası, hakemli ve yılda iki sayı yayımlanan dergidir. İngilizce ve Türkçe dilindeki metinler kabul edilir.  
The Researcher is a peer-reviewed, international journal publishing two issues a year. Manuscripts are accepted in English and Turkish languages.

**ANKARA, ARALIK 2022 / DECEMBER 2022**

## Önsöz

Yayın hayatına 2013 yılında başlamış olan "Researcher: Social Sciences Studies" (RSSS), 2020 Ağustos ayı itibariyle "Researcher" ismiyle Ankara Bilim Üniversitesi bünyesinde yayın hayatına devam etmektedir. Fen Bilimleri alanına katkıda bulunmayı hedefleyen özgün araştırma makalelerinin yayımlandığı bir dergidir. Dergi, özel sayılar dışında yılda iki kez yayımlanmaktadır.

Amaçları doğrultusunda dergimizin yayın odağında; Endüstri Mühendisliği, Bilgisayar Mühendisliği ve Elektrik Elektronik Mühendisliği alanları bulunmaktadır. Dergide yayımlanmak üzere gönderilen aday makaleler Türkçe ve İngilizce dillerinde yazılabilir. Dergiye gönderilen makalelerin daha önce başka bir dergide yayımlanmamış veya yayımlanmak üzere başka bir dergiye gönderilmemiş olması gerekmektedir. Bir makalenin dergide yayımlanabilmesi için en az iki hakem tarafından olumlu rapor verilmesi gerekir.

Değerlendirme sonucu kabul edilen çalışmalar sırasıyla; intihal kontrolünün yapılması, kaynakça düzenlenmesi, gönderme ve atıf kontrolü, mizanpaj ve dizgisinin yapılması süreçlerinden geçer.

Researcher, Dergipark üzerinden bilimsel araştırmaların içeriğine anında açık erişim sağlamaktadır.

Researcher makale işlem ücreti (gönderme, değerlendirme veya basım ücreti) ve makalelere erişim için abonelik ücreti talep etmediği için ücretsiz yayın yapan dergi statüsündedir, Dergimiz herhangi bir kâr amacı gütmemekte ve hiçbir gelir kaynağı bulunmamaktadır.

Baş Editör

**Doç. Dr. Hakan ÇAĞLAR**

Editör

**Dr. Öğr. Üyesi Yavuz Selim ÖZDEMİR**

## **İçindekiler / Index**

Interrelation and Succession of Application Results of the Wide Band Frequency Analysis in Numerical Electromagnetics: Shifted Frequency Internal Equivalence

**Ercüment KARAPINAR, Sevda ÖZDEMİR**..... 46-56

Investigation of Factors Affecting Life Satisfaction of Individuals with Ordinal Regression Analysis

**Alper CÜNEYT Türkmen, Hülya ŞEN**..... 57-72

Forecasting Probability of Risk Sea Accident with Machine Learning

**Ragıp ZİLCİ, Hakan AKYOL**..... 73-80

Game Theory Applications in Disaster Management Research

**Pınar USTA, Nesibe UYSAL, Özgür BOZDAĞ**..... 81-95

Frugal innovation concept as an indispensable solution for normal and crisis situations Morocco facing COVID-19

**Bilal KARROUMI, Abdelfettah SEDQUI**..... 96-105

Impact of Covid-19 on Employees Transportation in Morocco: Optimization using OCVRPTW

**Anas LAASSIRI, Abdelfettah SEDQUI,**..... 106-117

COVID-19: Perceptions of public transit passengers on its management and influence on sustainable transport in Ibadan

**Adeyinka AJAYI**..... 118-130

Optimum Power Flow by Using Interior Point Optimization Method

**Yunus YALMAN, Özgür ÇELİK, Adnan TAN, Kamil Çağatay BAYINDIR**..... 131-138

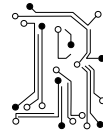

# Interrelation and Succession of Application Results of the Wide Band Frequency Analysis in Numerical Electromagnetics: Shifted Frequency Internal Equivalence

Ercüment KARAPINAR<sup>1\*</sup>, Sevda ÖZDEMİR<sup>2</sup>

<sup>1</sup>Ankara Science University, Faculty of Engineering and Architecture, Department of Electrical and Electronics Engineering, Ankara, Türkiye; ORCID: [0000-0002-9328-1969](https://orcid.org/0000-0002-9328-1969)

<sup>2</sup>Hacettepe University, Faculty of Engineering, Department of Electrical and Electronics Engineering, Ankara, Türkiye; ORCID: [0000-0003-1738-6264](https://orcid.org/0000-0003-1738-6264)

\* Corresponding Author: [ercument.karapinar@ankarabilim.edu.tr](mailto:ercument.karapinar@ankarabilim.edu.tr)

Received: 13 May 2022; Accepted: 31 July 2022

**Reference/Atf:** E. Karapınar and S. Özdemir, “Interrelation and Succession of Application Results of the Wide Band Frequency Analysis in Numerical Electromagnetics: Shifted Frequency Internal Equivalence”, Researcher, vol. 02, no. 02, pp. 46-56, Dec. 2022, doi:10.55185/researcher.1115406

## Abstract



Scattering problems have been evaluated and studied to reach to new solution methods by researchers. In this paper, the scattering calculation analysis in multi-frequency band is presented for the homogenous and the inhomogeneous 2D and 3D structures by the Shifted Frequency Internal Equivalence (SFIE). This paper is also a collection of the previous studies in one place, the interrelation of results on SFIE to enlighten the researchers on the subject matter for further research areas. This theory has shown that the electromagnetic field at frequency  $\omega$  inside the region can be solved by using a set of equivalent currents radiating at the different frequency  $\omega_0$ . This chosen  $\omega_0$  frequency is not changed while the incident field frequency changes. The analysis method in the literature requires repetition of the numerical analysis as many times as the number of the related frequency. Each repetition adds up to the computer time. SFIE algorithm which solves Electric and Magnetic Field Integral Equations (EFIE and MFIE) defines current equivalency covering the dielectric-magnetic features of the structure. SFIE applications are proved to give successful results for 2D and 3D arbitrary geometries. SFIE also provides very successful results for lossy objects.

**Keywords:** parallel computing, real-time systems, compilers

## 1. Introduction

Scattering is caused by the radiation of currents produced inside and on the surface of a structure excited by an electromagnetic wave. Since scattering problem has been an interesting problem. The solution techniques for the analysis of the scattering problems are accepted as a big contribution to paving the way for new approaches to solution methods. This study explains the results of the new method for analysis of the scattering problem. The new method uses Shifted Frequency Internal Equivalence (SFIE) [1,2]. SFIE method provides a fast solution for wideband electromagnetic scattering problems involving inhomogeneous, homogenous and lossy structures [3]-[7].

The solution need of the problems in the numerical analysis of scattering has increased with the requirements of modern technology of antennas and microwave devices etc. The solution algorithms of wide frequency band problems analyzed by Method of Moments (MoM) and Finite Element Method (FEM) are used to calculate the impedance matrix for each new frequency within the band.

It is known that integral equations are needed to solve for each new single frequency to find the scattering fields. Many methods are introduced to shorten and expedite this calculation burden, namely, interpolation, asymptotic approach, and characteristic basis function method [8]-[11]. So, methods are forced to find a solution by estimating a new MoM matrix. However, SFIE presents a new principle for which MoM matrix is not accepted an estimate calculation at each new frequency, on other hand, it is accepted as exact. SFIE calculates volume elements once and surface elements are recalculated for a new frequency. The equivalence of the fields is forced at the surface interface. Once the calculated

volume elements are inserted into the process as some constants, the calculations of all integral equations are not required. SFIE saves computation time significantly.

The SFIE principle can be used to provide an internal equivalence at a shifted frequency for electromagnetic scattering problems when a solution is needed in a band of frequency. With this method, the equivalent currents for the internally equivalent problem radiate a defined fixed frequency different from the frequency of the incident wave. These equivalent currents have parameters of the incident and shifted frequencies, material parameters, and the total field inside the body and on its boundary. A combination of this internally equivalent problem with an externally equivalent one, so as to match the tangential fields at the boundary of the body, results in the new formulation.

The formulation and its application to produce multifrequency solution by employing internal data generated at a single frequency in a volume-surface integral equation are explained and exemplified using various problems in the second section. The method and results for different geometries are given in the third and fourth sections, respectively. The conclusion of the theory is given in the fifth section.

## 2. Theory

Scattering is the natural phenomenon in which radiation is created by the currents produced in and on an object inflicted by an electromagnetic wave. A new approach to the analysis of the scattering, the principle of SFIE theory is to be explained in this section. The original problem and its internal equivalence are worth to be shown in Figure 1.  $V$  and  $S$  show volume and surface elements.  $V$  and  $S$  are converted to the surface and closed line integrals respectively in two dimensional structures, and to volume and surface integrals respectively in three-dimensional structure. It is shown that electromagnetic fields are excited by  $(\mathbf{J}\omega, \mathbf{M}\omega)$  and radiate in volume  $V$  with frequency  $\omega$  in Figure 1.

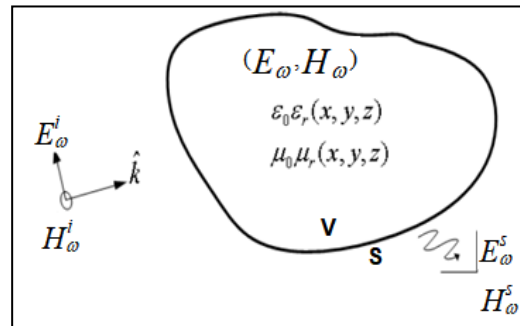

Figure 1:Original Problem

According to SFIE principle, the structure (Figure 1.) of the scattering problem can be represented by electric and magnetic sources in  $V$  and on  $S$  as shown in Figure 2 which is the internally equivalent problem of the original structure. The internal equivalence of the Figure 1 at the shifted frequency. Geometry is replaced with  $(\mathbf{J}_{\omega_0}^V, \mathbf{M}_{\omega_0}^V)$  and  $(\mathbf{J}_{\omega_0}^S, \mathbf{M}_{\omega_0}^S)$  equivalent sources. By the same token, the external equivalence of the original problem is shown in Figure 3. External equivalence of the problem is drawn by replacing geometry with  $(\mathbf{J}_{\omega_0}^S, \mathbf{M}_{\omega_0}^S)$  and the total field is the same as the original problem. The tangential fields on the surface are continuous and internal and external equivalent equations are written and matched at the surface. The SFIE theory basically asserts that the original problem in  $\omega$  frequency can be solved by using the equivalence principle in fixed  $\omega_0$  frequency. In the equivalent problem, the scattered waves can be calculated by a newly defined set of currents radiating in a fixed frequency  $\omega_0$  different from the  $\omega$  frequency. The resulted radiated fields are to be equivalent of radiated fields in the original problem.

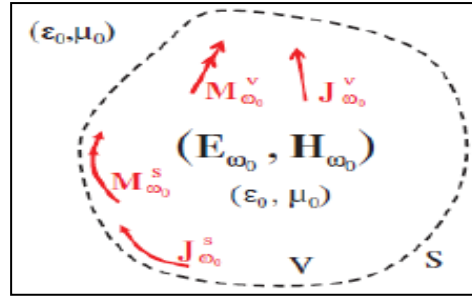

Figure 2: Internally Equivalent Problem

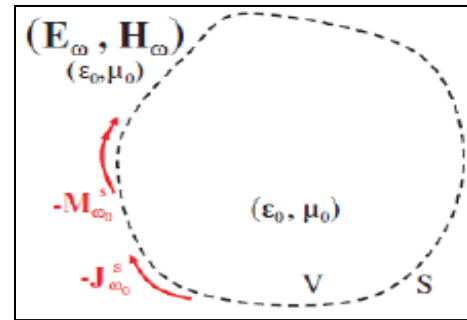

Figure 3: Externally Equivalent Problem

The internal equivalence section of the calculation from these integral equations is done just once by using SFIE since sources radiate at  $\omega_0$ . The formulation and the proof of SFIE theory are given in reference [1].

The equivalent current sources can be written as;

$$\mathbf{J}_{\omega_0}^V = j(\omega\epsilon - \omega_0\epsilon_0)\mathbf{E}_{\omega} \quad (1.1)$$

$$\mathbf{M}_{\omega_0}^V = j(\omega\mu - \omega_0\mu_0)\mathbf{H}_{\omega} \quad (1.2)$$

$$\mathbf{J}_{\omega_0}^S = -\hat{n} \times \mathbf{H}_{\omega} \quad (1.3)$$

$$\mathbf{M}_{\omega_0}^S = \hat{n} \times \mathbf{E}_{\omega} \quad (1.4)$$

As seen from the equations (1.1) - (1.4), the equivalent currents comprise the sources and the features

$$\mathbf{E}_{r\omega_0}(\mathbf{J}_{\omega_0}^v, \mathbf{M}_{\omega_0}^v, \mathbf{J}_{\omega_0}^s, \mathbf{M}_{\omega_0}^s) = \mathbf{E}_\omega \quad (2.1)$$

$$\mathbf{H}_{r\omega_0}(\mathbf{J}_{\omega_0}^v, \mathbf{M}_{\omega_0}^v, \mathbf{J}_{\omega_0}^s, \mathbf{M}_{\omega_0}^s) = \mathbf{H}_\omega \quad (2.2)$$

$$\hat{\mathbf{n}} \times [\mathbf{E}_{r\omega_0}(\mathbf{J}_{\omega_0}^v, \mathbf{M}_{\omega_0}^v, \mathbf{J}_{\omega_0}^s, \mathbf{M}_{\omega_0}^s)] \times \hat{\mathbf{n}} = \hat{\mathbf{n}} \times [\mathbf{E}_{r\omega}(-\mathbf{J}_{\omega_0}^s, -\mathbf{M}_{\omega_0}^s) + \mathbf{E}_\omega^i] \times \hat{\mathbf{n}} \quad (2.3)$$

$$\hat{\mathbf{n}} \times [\mathbf{H}_{r\omega_0}(\mathbf{J}_{\omega_0}^v, \mathbf{M}_{\omega_0}^v, \mathbf{J}_{\omega_0}^s, \mathbf{M}_{\omega_0}^s)] \times \hat{\mathbf{n}} = \hat{\mathbf{n}} \times [\mathbf{H}_{r\omega}(-\mathbf{J}_{\omega_0}^s, -\mathbf{M}_{\omega_0}^s) + \mathbf{H}_\omega^i] \times \hat{\mathbf{n}} \quad (2.4)$$

of the real structure.  $\hat{\mathbf{n}}$  is adjusted to be out of the surface. For external equivalence,  $(-\mathbf{J}_{\omega_0}^s, -\mathbf{M}_{\omega_0}^s)$  source currents are used, and the equation set (2.1) – (2.4) is derived.

By using these equivalent currents, calculation for SFIE principle can be made. These calculations are based on the equivalent problem of the original problem. The equations (2.1) and (2.2) are equations for volume equivalences for  $V$ , (2.3) and (2.4) are equations for surface tangent equivalences that match internal and external electric and magnetic tangential fields on the surface  $S$  [12]. The loss is added as conductivity constant and the equations are written for lossy case. Conductivity creates a current which can be written as  $\mathbf{J} = \sigma \mathbf{E}$  and this current changes the Ampere's equation as,  $\nabla \times \mathbf{H} = j\omega \mathbf{D} + \mathbf{J} = j\omega \epsilon \mathbf{E} + \sigma \mathbf{E} = j\omega(\epsilon - j\sigma/\omega) \mathbf{E}$ . The imaginary part in this equation gives the total loss and the loss tangent ( $\tan \delta = \sigma/\omega\epsilon$ ) defines the loss in the medium. The loss can be taken into account by using complex permittivity as  $\epsilon = \epsilon' - j\epsilon''$  [7].

### 3. Method

Before analyzing the approach to the scattering problem, it will be informative to define a scattering problem. The structure of the problem includes an inhomogeneous voluminous body and free sources in free space out of this voluminous structure. When the field radiated by these primary sources impinging on this body, secondary sources occur in the volume and on the surface of the structure. The scattering is created by these secondary sources.

The incident field is known but total field, which is the addition of incident and scattered, is not known. The solution for scattered field can be found by using Electric Field Integral Equation (EFIE) and/or Magnetic Integral Equation MFIE. The original problem is replaced with an equivalent problem and the scattered fields can be solved by using the equivalent current sources newly defined with SFIE principle. The required equation set can be configured by forcing the boundary conditions of the fields at the internal and external equivalence.

Due to fact that Volume Internal Equation (VIE) sources include electrical parameters of the geometric structure, VIE can be applied to solution of homogenous and inhomogeneous geometries. However, the Surface Integral Equation (SIE) is used only for homogenous structures. By taking into account the role of direction of surface normal  $\hat{\mathbf{n}}$  for the surface sources, special attention should be given to the selection of the direction of  $\hat{\mathbf{n}}$ . After the direction of  $\hat{\mathbf{n}}$  is defined according to internal or external equivalence, the direction of  $\hat{\mathbf{n}}$  is taken as “ $-\hat{\mathbf{n}}$ ” for the other equivalence.

The SFIE solution is done by a known numerical analysis, namely Method of Moment. This study is twofold: one is for verification of the validity of a theory and one is for the acquisition of the SFIE results. SFIE solutions are compared to MoM solutions. The important point here is to apply the problems with the same conditions and to present the acquired results with the same evaluation criteria. The solution for the application of SFIE principle is done the on the surface and in the volume of the problem physical structure.



In numerical analysis, the number of unknowns defines the number of independent equations to be derived. Let's assume that we have “ $n$ ” unknowns in volume and “ $s$ ” unknowns on the surface of the structure for discretization. In order to find the unknown total field ( $\mathbf{E}_\omega, \mathbf{H}_\omega$ ) by MoM, “ $n+s$ ” number of expansion functions are to be defined for the equation set given at (2.1) to (2.4). We have “ $n+s$ ” number of integral equations in  $V$  volume. These equations are tested at “ $n$ ” points in  $V$  so that “ $n$ ” number of internal products. We can test at “ $s$ ” points on the surface to derive “ $s$ ” number equations with “ $n+s$ ” number unknowns. As a result, “ $n+s$ ” number equations are found for “ $n+s$ ” unknowns.

It is worth mentioning here that, the SFIE equation set comprises fields and sources both at  $\omega_0$  and  $\omega$ . The components with  $\omega_0$  frequency are not needed to calculate again for numerical analysis for  $q$  new  $\omega$  frequency. So, when the solution is sought for multi-frequency, the matrix solution with  $\omega_0$  data can be used as many times as the new  $\omega$  frequency calculation required. This is the novelty of the application of SFIE. The steps for SFIE application algorithm are presented in Algorithm 1.

Algorithm 1: The steps for SFIE application algorithm

1	Choose and set the constant initial frequency $\omega_0$ .
2	Calculate matrix elements with $\omega_0$ for $Z_{VV}, Z_{VS}, Z_{SV}$ and $Z_{SS}$ . (subscripts “VV” denotes volume to volume, VS/SV denotes volume to surface and vice versa, SS denotes surface to surface interactions of MoM as explained above.)
3	Set frequency $\omega$ as of incident field.
4	Calculate $Z_{SS}$ matrix elements for the frequency $\omega$ .
5	Add $j(\omega\varepsilon - \omega_0\varepsilon_0)$ and $j(\omega\mu - \omega_0\mu_0)$ constants to the equation and multiply the matrix elements found in step 2 ( $c \otimes Z_{VV}, c \otimes Z_{VS}$ ).
6	Complete the equation set and solve for total fields.
7	Go back to step 3 for a new frequency solution and repeat for a new frequency.

As it is observed from this application steps of algorithm, SFIE can be accepted as a very suitable and adaptable solution methodology for wideband solution of scattering problems. Unlike MoM which requires to calculate surface and volume integrals for each frequency, SFIE principle eases the solution by multiplying the one-time calculated integral by a constant within the band. The results of the SFIE solutions are presented at next section. It takes longer with MoM calculation due to fact that it is required to calculate impedance matrix separately for each frequency. The impedance matrix calculation must be repeated that many times. Instead of this, having a different equivalent solution method in which the frequency is kept constant eases and speeds up the calculation process.

This study is exercised the TM mode solutions for 2D problems. It is known that TE mode solution will be the dual of the TM mode solution. The fields components for TM modes are  $E_z$ , and  $H_x, H_y$ . The currents are to be in the same direction with the fields as  $J_z$  and  $M_x, M_y$ .

It is well known fact that as much the modeling of the structure getting as close as possible to the physical structure, the error in results decrease. One major issue for this purpose is to make sure that tangential components must follow the surface exactly for 2D problems. Otherwise, the results deviate from the expected results. In this regard, the tangential magnetic field component will be applied with cautiously for TM mode. Similarly, the same discussion is valid for tangential electric field components in TE mode. It will be controlled and made sure that the direction of the line integral will be from start point to end point.

The other important mark for a numerical analysis application is about digitization of the geometrical structure and what kind of mesh structure to be applied. While a 3D structure has volume and surface parts, a 2D structure has surface and boundary lines for SFIE calculations. The volume integrals are converted to surface integral and surface integrals are converted to line integrals. For structure analysis, VIE is converted to SIE and SIE is converted to line integrals for 2D problems. In order to solve these integrals numerically, Gauss numerical integral is applied for line and volume integral calculations and DUNAVANT rule is used for surface integral calculations [12], [13].

The literature search has shown that the triangular mesh structure is more effective than the square cell mesh and tetrahedral mesh cell than hexahedral mesh cell. 2D structures are discretized with triangles by MATLAB® simulation program, 3D structures are discretized with tetrahedrons by Femlab® simulation program [14]. Basically, the maximum length of the mesh is guaranteed to be less than the dielectric wavelength. This rule asserted that maximum length of the triangle and tetrahedron is made less than 10 % of the dielectric wavelength in the related frequency.

An adaptive integration is applied for volume, surface, and line integrals in calculations to the extent which use an adaptive calculation algorithm rather than usage of higher order Gauss integration rules. The volume integrals are solved numerically by 2<sup>nd</sup> order Gauss rules with defined 4 points of a tetrahedron. The surface integrals are solved numerically by Gauss rules over triangle surfaces.

Special attention should be given here for the instance in which observation and field point meet at the same point on a calculation cell. This instance creates singularity which is required to be extracted. This extraction is applied by addition and subtraction of the logarithmic singularity.

## 4. Results

SFIE principle early application results for one-dimensional problem is given at [14]. The scattering created by the incident of plane wave on a 1D slab with an angle is searched. The acquired results are very promising such that the error rate is less than 1 % for the frequencies below  $\omega_0$  and the error rate decreases with the increasing number of segmentations. This section presents the application results of SFIE principle with 2D and 3D structures. The results of SFIE application are explained and verification of theoretical results is demonstrated. A scientific study should be able to give the comparison of the theoretical results with known and accepted methods of calculation results. The SFIE application results are presented with a comparison to results acquired from MoM. Before this comparison, the verification of MoM solution application is controlled to understand that the numerical solution exercise of MoM is applied in a correct way. MoM application is done in one frequency. Later, multi-frequency usage of SFIE theory is tired. Different structures such as homogenous, inhomogeneous, electrically small, and big have been solved by MoM. In order not to leave any point unchecked, 2D structures are calculated in both TM and TE mode also by constructing EFIE and MFIE.

### 4.1. 2D SFIE Application Results

This section explains the results of SFIE solution application for 2D homogenous and inhomogeneous structures. The various types of structures are examined according to their segmentation, the angle of incidence, and the electromagnetic size. The results of the incident angle are given for the incident angle at which the error is observed as maximum. The size of the structure is presented as the minimum dielectric wavelength at the maximum frequency of the related band. The Structures are changed from simple to complex geometries. The foremost advantage of SFIE theory is its usage over a wide frequency band with an acceptable percentage error rate. The results calculated from SFIE application are compared to Method of Moments (MoM) calculations. In this error analyses, percentage error rate is found as: Percentage Error Rate (%) =  $100 * \frac{||\text{MoM Result} - \text{SFIE Result}||}{||\text{MoM Result}||}$ . The initial frequency is chosen as 0.1 GHz and the frequency band is changed up to 1.2 Ghz.

The first structure is  $0.5\lambda \times 0.3\lambda$  solid dielectric rectangle with  $\epsilon_r=10$  and  $\mu_r=10$  and homogenous. Incident angle inflicts on the structure with an incident angle of  $\theta=180^\circ$ . The error percentage is given for the same number of discretized triangle numbers of MoM and SFIE calculations according to the increase in the number of discretization cells are depicted in Figure 4.1.

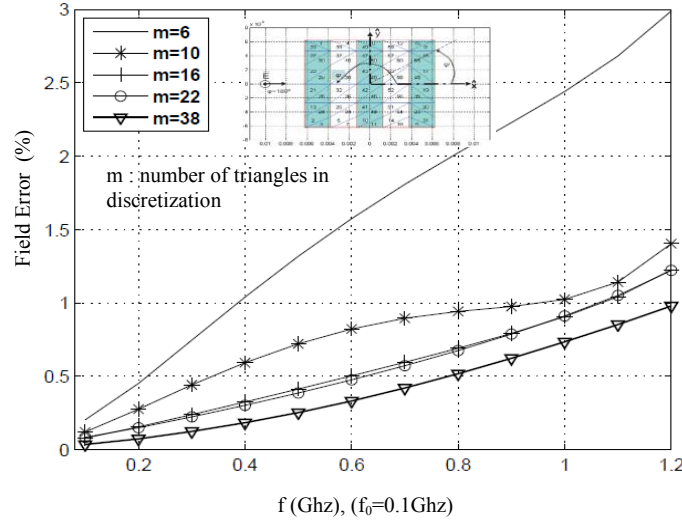

Figure 4.1: SFIE application comparison to MoM

The maximum segment size is no longer than  $0.1 \lambda$  for the highest frequency and the error rate decreases as the number of triangle cells increases. The other important points are that the triangle cell density is found to be more than  $200/\lambda^2$  to get an error rate of less than 5%. As long as the triangular segmentation density is kept accordingly the error rate is found acceptable up to 70% of the maximum frequency of the band.

The other comparison is made for the Radar Cross Section (RCS) calculations for the above structure of Figure 4.1. For RCS, the current sources calculated by MoM and by SFIE are compared. The comparison is calculated in L-2 norm percentage error and for different observation angles of  $\psi$ . The RCS calculation comparison is given for incident field angle  $\Theta=180^\circ$  and the triangle segment density  $107/\lambda^2$ . The error percentage results are shown at fig.4.2.

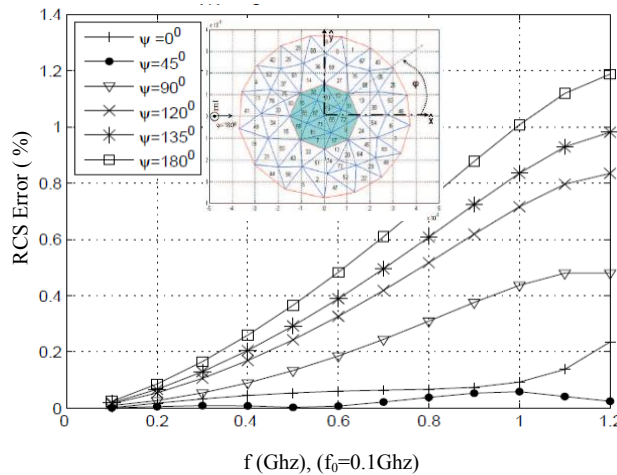

Fig.4.2: SFIE application comparison to MoM

Another SFIE application is done for a cylindrical structure of radius  $0.25 \lambda$  outer and  $0.125 \lambda$  inner radius two concentric circular areas. The inner-circle has  $\epsilon_r=10$  and  $\mu_r=6$  and the outer circular area has  $\epsilon_r=6$  and  $\mu_r=10$  for an inhomogeneous structure. The results of error % change according to the increase in the number of discretization cells are depicted in Figure.4.3. The RCS calculation comparison is given for incident field angle  $\Theta=180^\circ$  and the triangle segment density  $107/\lambda^2$ . The results are shown in Figure 4.4.

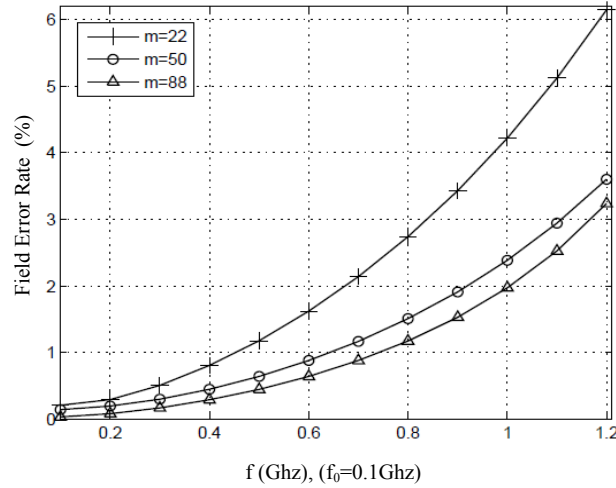

Fig.4.3: SFIE application comparison to MoM

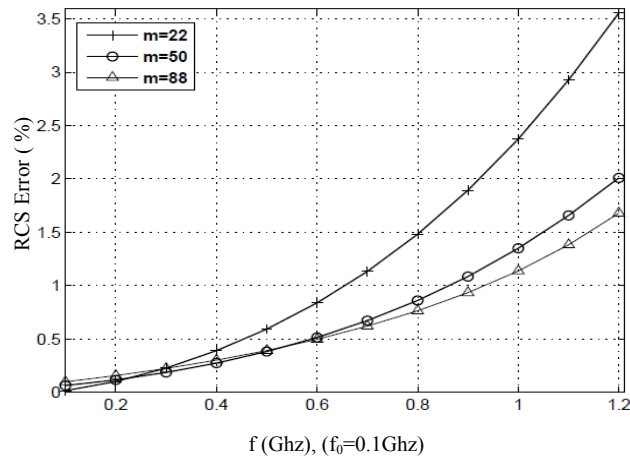

Fig.4.4: RCS calculation result

As seen from the fig.4.3 and fig.4.4, the error rate decreases with the increase in the segment number. Triangle segment density  $112/\lambda^2$  for 22 cells,  $254/\lambda^2$  for 50 cells and  $448/\lambda^2$  for 88 cells. The results are shown at fig.4.4.

#### 4.2. 3D SFIE Applications Results

This section explains the results of the SFIE solution for applications for 3D homogenous and inhomogeneous structures. Among other applications, the sphere and cube geometries are chosen as representation models for 3D SFIE applications.

The first one is a sphere with a radius of  $0.1\lambda_0$  that has  $\epsilon_r = 2.0 - j1.2$  and  $\mu_r = 1.0$  for initial frequency  $f_0 = 1$  GHz. Calculating the results for the number of 756 subdivisions, the error is below 8% for field calculations and below 2% for RCS calculations in the band of 0.1-1 GHz bandwidth. The results of applications are depicted at Fig. 4.5 [12, pages 94-95].

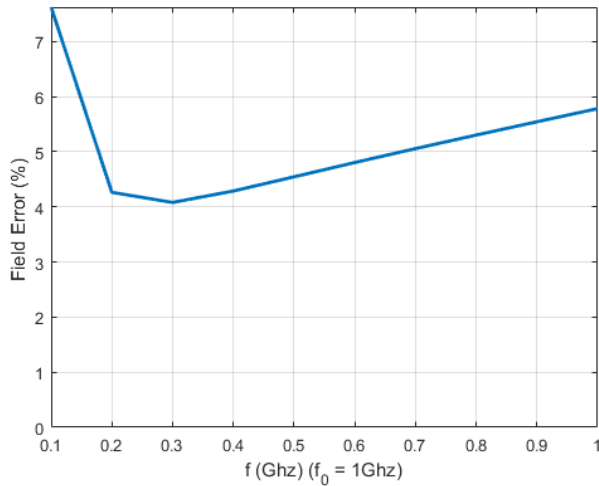

Figure 4.5(a)

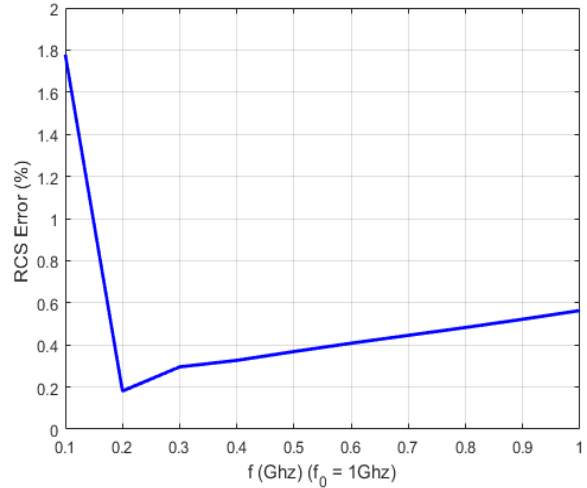

Figure 4.5(b)

Figure 4.5(a): Field error between SFIE and MoM-VIE, b) RCS error between SFIE and MoM-VIE for a lossy sphere ( $r=0.1\lambda_0$ ,  $\epsilon_r = 2.0-j1.2$  and  $\mu_r=1.0$ )

The other solution is the scattering calculation of two concentric spheres with  $0.1\lambda_0$  and  $0.2\lambda_0$  radii. Inner one has  $\epsilon_r = 2.0$  and outer one has  $\epsilon_r = 4.0$ , both has  $\mu_r=1.0$ . Calculating the results for the number of 1233 subdivisions, SFIE scattering calculation error is below 7% in the 0.1-1 GHz bandwidth and RCS error below 1% up to 0,2 Ghz. The results of applications are depicted at Fig. 4.6 [12, pages :89-90]

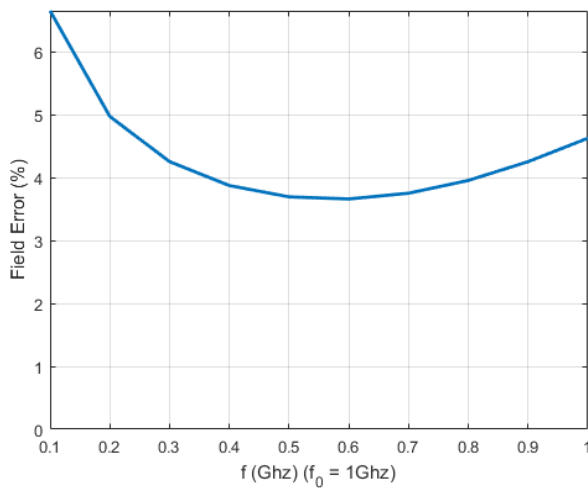

Fig.4.6 (a)

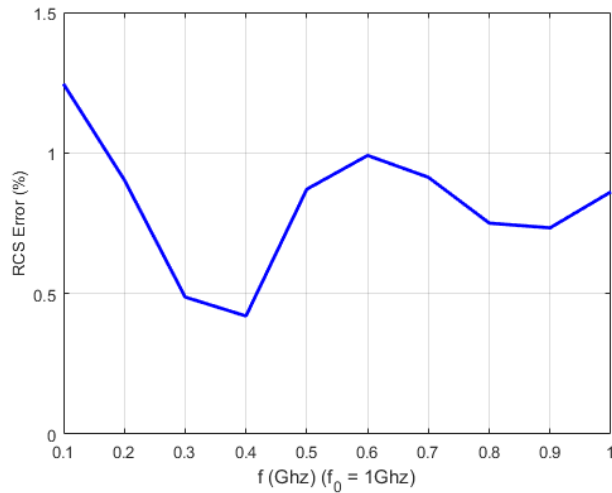

Fig.4.6 (b)

Fig.4.6 (a): Field error between SFIE and MoM-VIE, Fig.4.6 (b): RCS error between SFIE and MoM-VIE for two concentric spheres ( $r=0.1\lambda_0$ ,  $\epsilon_{r1} = 2.0$ ,  $\epsilon_{r2} = 4.0$  and  $\mu_{r1,2}=1.0$ )

One composite structure is taken as inserting an air-filled cube ( $\epsilon_r = 1.0$  and  $\mu_r=1.0$ ) between two cubes all which have  $0.1\lambda_0$  dimension. Let the cube at left have  $\epsilon_r = 2.0$  and  $\mu_r=1.0$ , right one have  $\epsilon_r = 4.0$  and  $\mu_r=1.0$ . SFIE scattering calculation error is below 7% and RCS error below 2% after 0.2 Ghz in the 0.1-1 GHz bandwidth. The results of applications are depicted at Fig. 4.7. [12, pages :92-93]

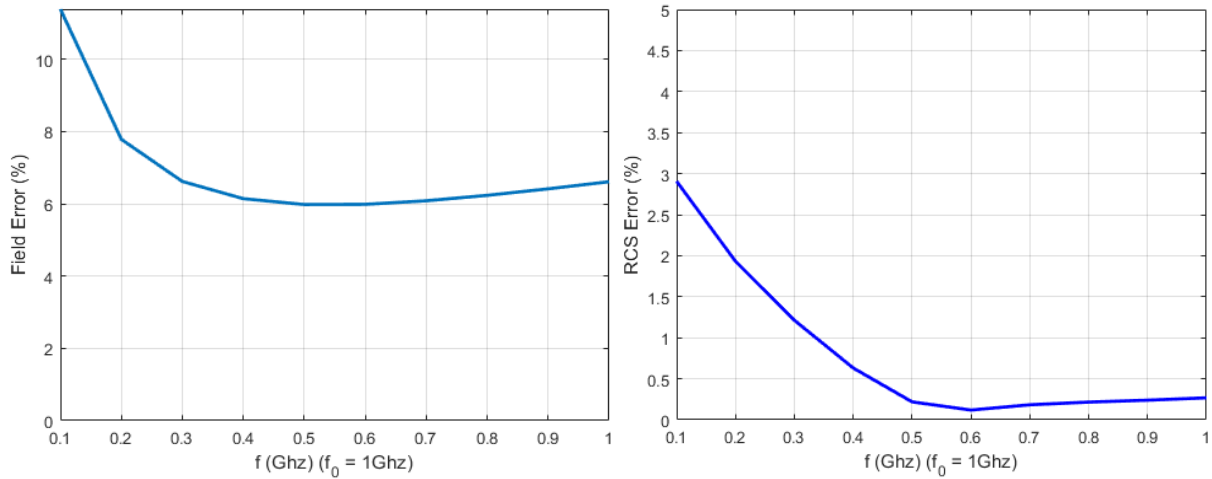

Fig.4.7 (a): Field error between SFIE and MoM-VIE, Fig.4.7 (b): RCS error between SFIE and MoM-VIE for an air cube inserted between two cubes ( $l_{1,2}=0.1\lambda_0$ ,  $\epsilon_{r1} = 2.0$ ,  $\epsilon_{r2} = 4.0$  and  $\mu_{r1,2}=1.0$ )

## 5. CONCLUSION

### 5.1 SFIE Application Results

This study explains the application of SFIE theory for arbitrary homogenous and inhomogeneous 2D and 3D structures. The scattering analysis of a structure is solved by SFIE application in a frequency band and compared to the results acquired from MoM solution. This comparison is done to verify the accurateness of the SFIE method.

Electric and Magnetic Field Integral Equations (EFIE and MFIE) are solved for the surface and volume currents in SFIE algorithm which guarantees the equivalency of tangential components of internal and external fields and constructs a single impedance matrix. SFIE is based on the solution of the equation set which is formed as equating tangential field components of the internal equivalence of the problem at  $\omega_0$  frequency and the external problem of the at  $\omega$  original frequency. By this basic principle, SFIE defines volume current equivalency which comprises the dielectric-magnetic features of the structure and makes the calculation in a shifted frequency other than the problem. As a result, the problem is made free from frequency change. After finding the solution for the shifted frequency, the other frequency solutions can be found by multiplying the core impedance matrix by a fixed number set in SFIE [3,4]. Pulse expansion and point matching methods are used for the application of SFIE. The surface of the structure is digitized with triangles in 2D and tetrahedrons in 3D applications. In order to prevent the singularity of integral equations, some volume integrals are converted to surface integrals and some surface integrals are converted to line integrals. If this is not applied for singularity extraction, the analytical solution is used.

It is observed that the percentage error rate is less than 4 % when triangular segment density is higher than 200 per  $\lambda^2$  for 2D applications. For the 3D applications, the error rate is less than 10 % with the appropriate subdivision of the related geometry. While keeping this density error convergence is very successful up to 70 percent band of the maximum frequency of the related frequency band. This is a very important and successful result for problems of scattering in a wide frequency band. While it is required to make the solution for each new frequency for the Volume Integral Equation solution of Method of Moments, SFIE is very useful to make a solution in one initial frequency and fill some impedance matrices once then use these matrices for all required frequency. This also results in saving CPU time.

## 5.1 The Usage of SFIE and Advice for Future Work

The electrical features of the structure to be analyzed affect the SFIE application in regard to providing an acceptable solution. That the geometry has relatively small environmental parameters provides the ability to have a successful solution with less segmentation. That means one of the two same-size structures with smaller electromagnetic parameters requires a smaller number of segmentations.

SFIE application can be used for wide frequency band solutions. SFIE can be a very useful asset for different applications such as antenna with Radom analysis, frequency selective surfaces analysis, scattering application of fine element method, and dielectric patch line circuit analysis.

## Contribution of Researchers

All researchers have contributed equally to writing this paper.

## Conflicts of Interest

The authors declare no conflict of interest.

## References

- [1] A. Köksal, "Shifted-Frequency Internal Equivalence", IEEE Trans. Microw. Theory Tech., Vol. 46, No. 1, pp. 76-81, Jan. 1988.
- [2] A. Köksal, "Multifrequency Formulation for Electromagnetic Scattering Using Shifted-Frequency Internal Equivalence", IEEE Trans. Microw. Theory Tech., Vol. 47, No. 2, pp. 150-155, Feb. 1999.
- [3] A. Ünal, S. Özdemir, A. Köksal, "A Direct Proof of SFIE", IEEE Trans. on Antennas and Propagation, Vol. 66, No. 4, pp. 2141-2142, Apr. 2018.
- [4] E. Karapınar, "Shifted frequency internal equivalence 2D application", 2009 International Conference on Electrical and Electronics Engineering - ELECO 2009, Bursa, 2009, pp. II-280-II-283.
- [5] S. Özdemir, A. Ünal, A. Köksal, "Application of Shifted Frequency Internal Equivalence to Multi-frequency Scattering Problems", IEEE Trans. on Antennas and Propagation, Vol. 65, 9, Sept. 2017.
- [6] A. Ünal, E. Karapınar, and A. Köksal. "Accuracy and bandwidth investigation of shifted frequency internal equivalence in 2D." 2014 IEEE Antennas and Propagation Society International Symposium (APSURSI). IEEE, 2014.
- [7] B. Aydemir, A. Köksal, "Application of the Shifted Frequency Internal Equivalence to Two Dimensional Lossy Objects", Advanced Electromagnetics, VOL. 8, NO. 2, September 2019.
- [8] R. F. Harrington, "Field Computation by Moment Methods", Macmillan, New York, US, 1968.
- [9] J. Jin, "The Finite Element Method in Electromagnetics", John Wiley & Sons, New York, US, 2014.
- [10] L. Zheng-liang, G. Shu-xi, M. Ji and W. Xing, "Impedance matrix interpolation based on method of moments for solving radiation problem over a frequency band", Int. Con. On Micr. And Millimeter Wave Tech., 3, 1, 1-3, 2012.
- [11] V. V. S. Prakash and R. Mittra, "Characteristic basis function method: A new technique for efficient solution of method of moments matrix equations", Microw. And Opt. Tech., 36,2,95-100,2003.
- [12] Nagaraja, K.V., Rathod, H.T., Symmetric Gauss Legendre Quadrature Rules for Numerical Integration over an Arbitrary Linear Tetrahedra in Euclidean Three-Dimensional Space, Int. Journal of Math. Analysis, 4, 19, 921-928, 2010.
- [13] D.A. Dunavant, 1985, "High Degree Efficient Symmetrical Gaussian Quadrature Rules for The Triangle", Int.Journal For Numerical Methods In Eng. Vol.21, 1129-1148.
- [14] S. Özdemir, "Application of Shifted Frequency Internal Equivalence to 3D Electromagnetic Scattering Problems", Phd Dissertation, Hacettepe University, 2016.
- [15] D. R. Wilton, S. M. Rao, A. W. Glisson, "Potential integrals for uniform and linear source distributions on polygonal and polyhedral domains", IEEE Transactions on Antennas and Propagation Theory, AP-32, 3, 276-281, 1984.
- [16] A. Köksal, "Multifrequency Formulation for Electromagnetic Scattering Using Shifted -Frequency Internal Equivalence", IEEE Trans. M.T.T., vol.47, pp. 150-155, 1999.



## Investigation of Factors Affecting Life Satisfaction of Individuals with Ordinal Regression Analysis

Alper Cüneyt TÜRKMEN<sup>1\*</sup>, Hülya ŞEN<sup>2</sup>

<sup>1</sup>Eskişehir Osmangazi Üniversitesi, Eskişehir, Türkiye; ORCID: [0000-0003-3211-5059](https://orcid.org/0000-0003-3211-5059)

<sup>2</sup>Hacettepe Üniversitesi, Ankara, Türkiye; ORCID: [0000-0002-9095-3643](https://orcid.org/0000-0002-9095-3643)

\* Corresponding author: [alpercuneytturkmen@gmail.com](mailto:alpercuneytturkmen@gmail.com)

Received: 3 October 2022; Accepted: 8 December 2022

**Reference/Atf:** A. C. Türkmen, H. Şen, "Investigation of Factors Affecting Life Satisfaction of Individuals with Ordinal Regression Analysis", Researcher, vol. 02, no. 02, pp. 57-72, Dec. 2022, doi:10.55185/researcher.1183751

### Abstract



More than one factor can affect the life satisfaction of individuals. Examples of these are factors such as gender, educational status, marital status, health status, income status, social life, environmental factors and economic security. The aim of this study is to determine the factors affecting the life satisfaction of individuals by making use of the 2019 Life Satisfaction Survey data made by the Turkish Statistical Institute (TUIK). The satisfaction variable of the dependent variable was selected and analyzed with the SPSS package program. With the Ordinal Logistic Regression Analysis, the happiness levels were examined according to their socio-demographic characteristics and the results obtained were interpreted statistically. In the analyzed results; It has been revealed that demographic characteristics and time can change satisfaction, in addition to these, education, health status, income status are statistically significant in terms of life satisfaction.

**Keywords:** life satisfaction, ordinallogisticregression analysis, proportionalodds model (pom)

### 1. Introduction

Life satisfaction research is research conducted to measure individuals' perspectives on events. The variables of life satisfaction and future expectation of individuals were examined and interpreted with ordinal regression analysis.

Life satisfaction is the individual's ability to enjoy life and enjoy the situations in life. The first conceptual emergence of life satisfaction takes place in Neugarten's work [1]. Life satisfaction and life satisfaction can also be expressed semantically similarly.

The main purpose of the Life Satisfaction Survey is; It is to monitor the change of these satisfaction levels in the process by measuring the happiness of individuals in general, social values, satisfaction in the fields of "health and social security, education, working life, income, personal security and justice services, personal development, hope for the future" in their basic life, and satisfaction with public services. [2].

Life satisfaction, in other words, life satisfaction is the emergence of results according to the life options chosen by the individual in line with the impression of life. At the same time, life satisfaction is defined as "a psychological feature caused by people's outlook on life, their expectations of life and their level of satisfaction" [3].

The terms "quality of life", "happiness" and "well-being" imply different meanings. Sometimes it is expressed as a general term for all values, sometimes it refers to specific values. This general term and specific values refer to the four qualities of life. These four qualities are specified as:

1. The environment is livable
2. The individual's life skill
3. The benefit of external elements of life
4. Appreciation in life



Quality of life consists of a combination of subjective and objective factors that include happiness, health, good physical condition, intimacy, security, and social feelings of the individual's mental state [4].

Logistic regression analysis is divided into three groups. The first one is binary logistic regression (bistate logistic regression), multinomial logistic regression (multinomial logistic regression) and ordinal logistic regression (ordinal logistic regression), which is determined by the number of dependent variables and the type of scale. Binary logistic regression is used when the dependent variable is in the form of data with two categories, and multinomial logistic regression is used when the dependent variable is in the form of data with more than two classifications and no order. The ordinal data form of the dependent variable with at least two categories is the ordinal (ordered) logistic regression model [5].

Goodness of fit is evaluated as it is important in the ordinal logistic regression model and all regression models. It happens that the independent variables model of the model created under the conditions where the goodness of fit, which is the measure of sufficiency in expressing the dependent variable, does not meet the necessary conditions. Thus, the test of goodness of fit with the independent variable that is different when establishing the model can yield more reliable results in determining the independent variables of the dependent variable [6].

## 2. Literature Review

The literature on the concepts of life satisfaction and ordinal regression is given below under headings.

### 2.1 Life Satisfaction

When the studies on life satisfaction in Turkey are examined, it is seen that the number of studies is low. Other studies can be summarized as follows;

The life satisfaction of individuals was investigated by discriminant analysis by using the TUIK-2007 survey data on life satisfaction. Differences in life satisfaction were observed according to certain distinctions. These are rural-urban and gender differences. On the other hand, the correct classification percentage of the answers to the question "satisfied with public service" in the rural-urban distinction was found to be 90% [7].

Kahyaoğlu [8]. used Sequential Probit Models in his study titled "Life Satisfaction and Variables Affecting Life Satisfaction and Econometric Application: The Case of Turkey" and the results were interpreted statistically and economically. As a result of the study, it was seen that women were happier than men and that the relationship between age and happiness was U-shaped. At the same time, it has been determined that health, income, living in the city, and increases in welfare increase happiness levels.

In the study conducted by Akin and Şentürk [9], the relationship between individuals' happiness levels and socio-demographic characteristics was examined and the results obtained by applying sequential logistic regression analysis were compared with previous studies on the subject. In the results obtained, it was stated that the level of happiness by years was not similar in terms of socio-demographic characteristics, but generally the same results.

Dursun and İstar [10], in their study titled "The Effect of Work-Family Conflict of Female Employees on Job and Life Satisfaction", the results were interpreted statistically. As a result of the study, it was concluded that female employees have a negative effect on job and life satisfaction.

Filiz [11] applied the questionnaire consisting of employee satisfaction and life satisfaction scales to 186 academicians working at Osmangazi University; It has been concluded that it has an effect on colleagues, management status, development and advancement advantages, wages and workplace life satisfaction.

In the study conducted by Arı and Yıldız [12], the factors affecting life satisfaction of individuals were analyzed using ordinal logistic regression models.

On life satisfaction studies, it has been determined that 141 young people's impressions of the various emotional, social and behavioral effects of young people in life, and that positive life satisfaction makes young people look ahead with optimism [13].

According to the results of the research at the provincial level in 2013 on the impressions of life satisfaction, the symptoms of both the happiest and the unhappiest provinces were analyzed by considering the social, economic and political (2009-2014 local elections). According to the results, the happy provinces are compared to the unhappy provinces; unemployment, sales in residences, increase in divorce, electricity use per capita, population density was lower. The number of cars per capita (per thousand), the rate of households owning a home, the net enrollment rate in primary schools, and the number of hospital beds per capita (one hundred thousand) were higher [14].

Palmore and Luikart (1972), in their studies, determined that organizational activities, beliefs and internal control variables are the most important factors that determine life satisfaction.

Schyn (2002) in his study of 42 countries for the relationship between life satisfaction and income level revealed that the factors in the relationship between them were stronger in poor countries [15].

Ramachandran et al. (2012), in research studies affecting life satisfaction of elderly people living in Japan and India, it was determined that although they have a lower socio-economic status, their life satisfaction is higher in people living in India [16].

## 2.1 Ordinal Regression

Ordered logistic regression models; It has been applied recently in many fields such as medicine, economics, biology and agriculture. The literature review of the studies in which the ordinal logistic regression model was applied can be listed as follows.

Studies applied by Emeç (2002), [17]. in the examination of consumption expenditures in the Aegean Region, in the same way with sequential logistic regression methods, Choi et al. (2004) [18]., ordinal logistic regression models were examined by fitting them with data expansion. It was applied by Ayhan (2006) to examine the factors affecting nurses' intention to quit their job in Turkey [19].

According to Nizam (2007), using the ordinal logistic regression method, the capacity utilization of inpatient treatment institutions in Turkey was examined. Using the statistical data of 2005 by Nizam and Akdeniz (2007), the current occupancy usage conditions of the inpatient treatment institutions of the Ministry of Health; He applied the analysis as "low", "medium" and "high" levels. With the purpose of the model, estimation was made from the categorized logits consisting of medium and high [20].

Demirtas et al. (2008), in the study applied by; In the design of kitchen fixtures, a two-stage approach has been made on the condition of optimizing the design levels according to the visual perceptions of the users by adding the user feelings to the design process. According to the results of linear and ordinal logistic regression, the relationship between users' general preference scores and word scores was examined [21].

In the study conducted by Das and Rahman (2011), malnutrition risk factors of children were determined by using the data of "Bangladesh Demographic and Health Survey 2004" with ordinal logistic regression analysis [22].

In the study conducted by Akın and Şentürk (2012), sequential logistic regression analysis was applied to examine the relationship between the happiness levels of individuals and their socio-demographic characteristics, and the results were compared with previous studies on the subject. In the results obtained, it was stated that the level of happiness by years was not similar in terms of socio-demographic characteristics, but generally the same results.

Yavuz et al. (2013), determining the factors affecting the urban satisfaction of university students by applying ordinal logistic regression analysis [23].

Yakut et al. (2015), the classification success of the Human Development Index was compared by applying sequential logistic regression and artificial neural networks. In the study, the data of 81

countries between 2010 and 2012 were applied to the United Nations Development Program Human Development Index [24].

In the study applied by Aytekin and Tunalı (2017); In the application of binary logistic regression analysis, the life satisfaction of the research assistants, which is the dependent variable, was examined on the condition that the model fit was not met with the assumption of ordered logistic regression and multinomial logistic regression analyzes [25].

Usta et al. (2018), using logistic regression analysis, determined the reasons for university students' absenteeism. The "non-attendance tendency" was examined as a three-order category, which is the dependent variable, and the effects of variables such as gender, grade level and faculty were investigated [26].

### **3. Material and Method**

#### **3.1 Purpose of the research**

The aim of this study is to benefit from the survey data of the life satisfaction survey conducted on 9212 people in 2019 by the Turkish Statistical Institute (TUIK);

- To determine the life satisfaction levels of individuals (Education, Health, Work life, Future expectations, Income, Service, Personal Security)
- To determine the effect of health and general services on life satisfaction,
- To determine the factors affecting the life satisfaction of individuals,
- Analyzes and comments were made on the factors affecting happiness with ordinal (ordinal) logistic regression and their socio-economic effects.

For this purpose, estimations were made for dependent variable life satisfaction through the SPSS package program and the results were analyzed.

#### **3.2 Research Method**

In the method of the research, the data sets of the Life Satisfaction Survey (YMA) questionnaire were used by the Turkish Statistical Institute (TUIK) to determine the effects on life satisfaction. IBM SPSS Statistics 18.0 program was used in the analysis. Samples used in this study, dependent and independent variables, and hypotheses are defined under the subtitle.

In the Life Satisfaction Research study, life satisfaction (happiness) of individuals as dependent variables, gender, age, marital status, education level, health status, working status, social life, relatives, friends, neighbor relations and public services satisfaction are used as independent variables.

#### **3.3 Research Model and Hypotheses**

The schematic model of the hypotheses to be tested in the Life Satisfaction Survey is shown in Figure 1. In the model of the study, the demographic characteristics of individuals, satisfaction in their individual situations and satisfaction with public services were established and estimated as variables. Then, the hypotheses according to the model were listed.

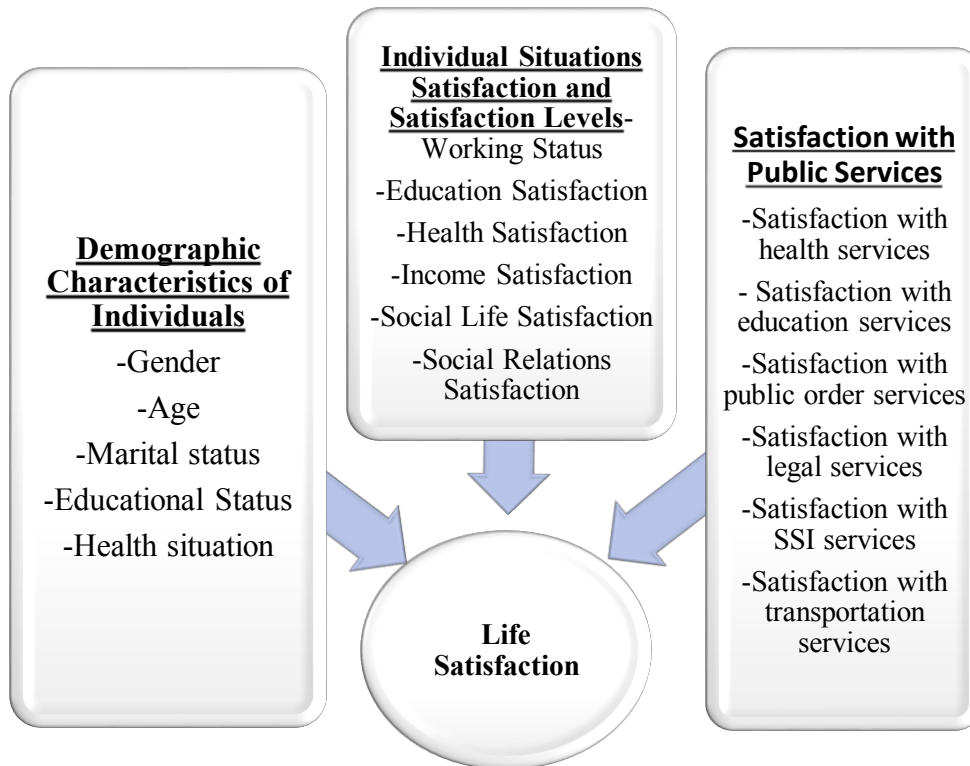

Figure 1: Life Satisfaction Survey Model

Hypotheses on Life Satisfaction.

**H<sub>1</sub>: In the demographic characteristics of individuals in Life Satisfaction;**

- Gender, there is a significant difference between.
- There is a significant difference between age.
- Marital Status, there is a significant difference between.
- There is a significant difference between Educational Status.
- There is a significant difference between Health Status.

**H<sub>2</sub>: The status and level of Individuals' Life Satisfaction;**

- There is a significant difference between Employment Status.
- There is a significant difference between Education Satisfaction.
- There is a significant difference between Health Satisfaction.
- There is a significant difference between Income Satisfaction.
- There is a significant difference between Social Life Satisfaction.
- There is a significant difference between Social Relations Satisfaction.

**H<sub>3</sub>: In public services in Individuals' Life Satisfaction;**

- There is a significant difference between satisfaction with health services.
- There is a significant difference between satisfaction with education services.
- There is a significant difference between satisfaction with public order services.
- There is a significant difference between satisfaction with legal services.

- There is a significant difference between satisfaction with SGK services.
- There is a significant difference between satisfaction with transportation services.

#### 4. Results

##### 4.1 Demographic Predictors of Life Satisfaction

In this study, data related to the 2019 Life satisfaction survey conducted by TURKSTAT were used. The research was studied with a total of 9212 data.

##### 4.1.1 Gender

In the gender profile of the research, it is seen that 54% of the respondents are female and 46% are male.

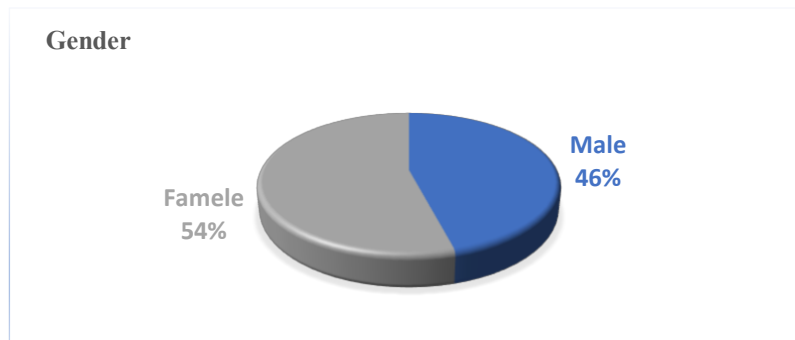

Figure 2: Gender Distribution of Individuals

##### 4.1.2. Age

In the study conducted by TUIK with a sample of 9212 people, the ages of the respondents were between the ages of 18 and 97. Ages are grouped as 18-24, 25-34, 35-49, 50-64 and over 65 years old. According to the observed values, the highest participation is between the ages of 35-49 with 32%.

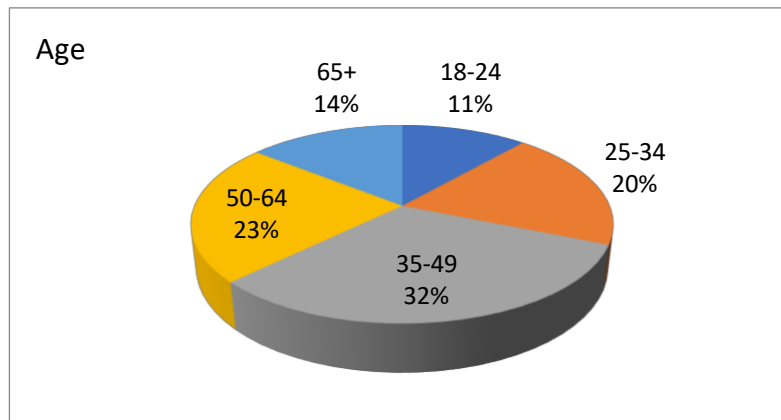

Figure 3: Age Distribution of Individuals

##### 4.1.3. Marital status

Considering the marital status distribution of the respondents, it is seen in Figure 4 that the difference between them is high. According to these distributions; 73% of the participants are married, 17% are never married, 7% are widowed and 3% are divorced.

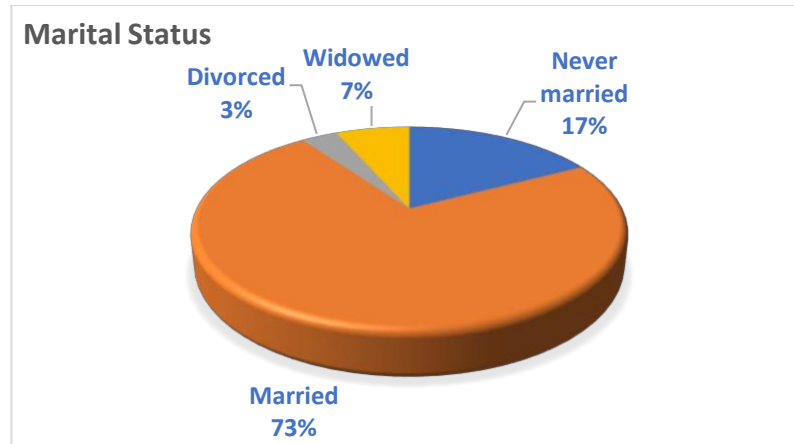

Figure 4. Distribution of Individuals in Marital Status

#### 4.1.4. Level of education

When the education level distributions of the respondents are examined, in the education organized by categorization, 35% of the highest participation is composed of primary school graduates. Respectively, it consists of 20% General-Vocational High School graduates, 19% Higher Education graduates, 14% did not finish school, and finally 12% General-Vocational Secondary School graduates.

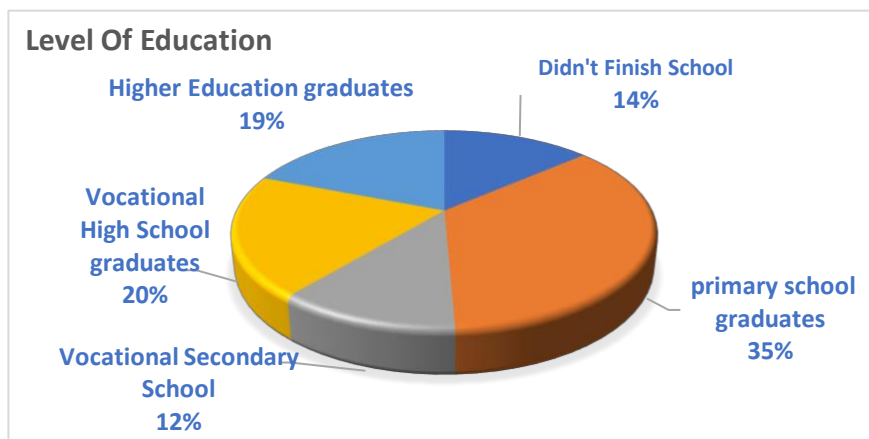

Figure 5. Distribution of Individuals Education Levels

## 4.2. Descriptive Statistics of Variables

A total of 9212 people between the ages of 18 and 97 participated in the Turkey-wide 2019 life satisfaction survey by the Turkish Statistical Institute (TUIK). In the descriptive statistics of the variables, the distribution of the happiness level of the individual, the results of the analysis of what makes the individuals happy the most and who makes the individuals happy the most are stated.

### 4.2.1. How Happy Are You

Figure 6 shows that 47% of the respondents feel happy, approximately 33% feel moderate, approximately 10% feel unhappy, approximately 7% feel very happy, and approximately 3% feel very unhappy. According to these values, it is seen that individuals feel happy the most and feel very happy and very unhappy at the least.

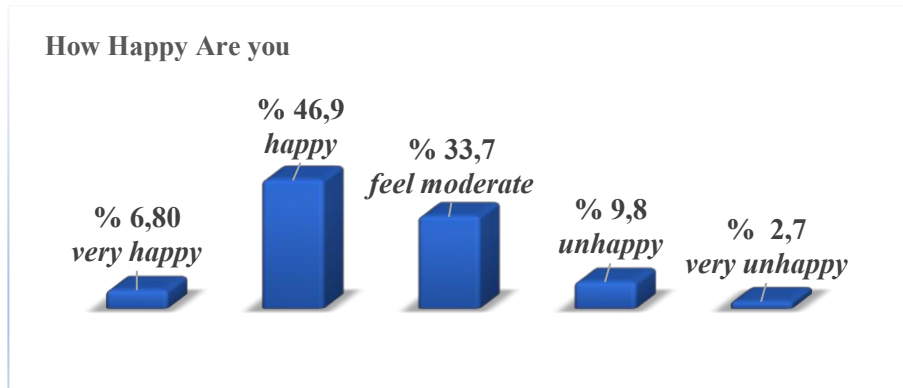

Figure 6. Distribution of Individuals in Happiness Level

#### 4.2.2. What Makes You Happiest in Life

In the distribution of what makes individuals happy the most, the distribution of the percentages of success, work, health, love, money and other options in the question of what makes them happiest in life is shown in the graph, and when we look at what makes individuals happy the most, it is seen that 71% is health, approximately 15% is love. It can be seen in figure 7 that is 8% is success, 4% is money, 2% is work, and only a few are others.

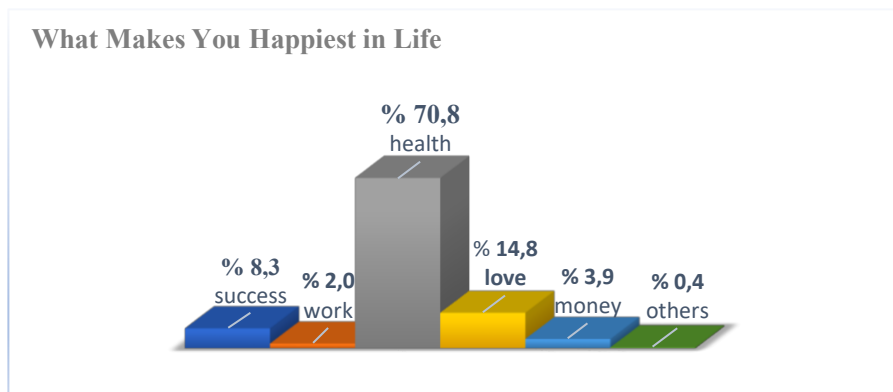

Figure 7. Distribution of What Makes Individuals Happy Most

#### 4.2.3. Who Makes You Happiest in Life

In the distribution of who makes the individuals the happiest, the distribution of the percentages of the self, children, mother/father, friends, nephews, grandchildren, spouse, whole family and other in the question of who makes the most happy in life is shown and interpreted in Figure 8.

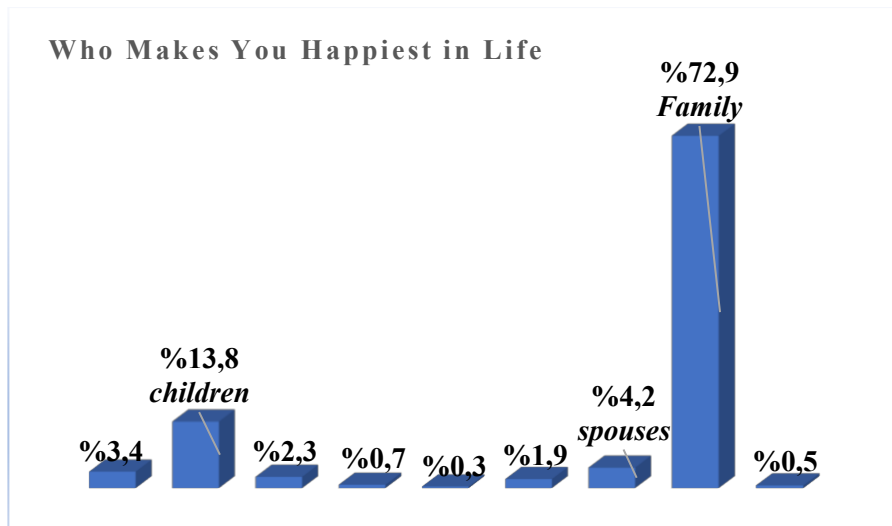

Figure 8. Distribution of Who Makes Individuals Happiest Most

When we look at who makes the individuals happiest in life, it is seen that 73% is the whole family. Considering other factors, it is seen in figure 8 that approximately 14% are children, 4% are spouses, approximately 3% are their own, and approximately 2% are parents and grandchildren.

### 4.3. Happiness Levels

By making use of the TUIK 2019 Life Satisfaction Survey data; The results of the analysis of happiness levels according to gender, age, marital status, education level, industry, future expectation and health status are shown in the tables.

#### 4.3.1. Happiness Levels by Gender

Table 1. Happiness Levels by Gender

Variables	Categories	Participant Percentages %	Happy	Moderately Happy	Unhappy
Gender	Men	45,9	49,6	36,3	14,2
	Women	54,1	57,3	31,5	11,2

The results obtained according to the information in Table 1; When the gender variable is examined, it is observed that women (57.3%) are happier than men (49.6%). It is seen that men (14.2%) are also unhappy compared to women (11.2%). As a result, women are happier than men.

#### 4.3.2. Happiness Levels by Marital Status

Table 2. Happiness Levels by Marital Status

Variables	Categories	Participant Percentages %	Happy	Moderately Happy	Unhappy
Marital status	Single	17,3	47,4	38,9	13,7
	Married	72,8	56,7	32,3	11,0
	Divorced	3,3	28,5	41,4	30,1
	His wife is dead	6,6	50,6	30,9	18,5

Happiness levels by marital status are shown in Table 2. Looking at marital status, those with the highest level of happiness are married individuals. (56.7%). The happiness rate of single individuals is seen as



(47.4%). Looking at the level of unhappiness, divorced individuals were the highest. According to the conclusion to be drawn from this, it can be observed that there is an increase in happiness after marriage.

#### 4.3.3. Happiness Levels by Age Distribution

Happiness levels by Age Distribution are shown in Table 3.

Table 3. Happiness Levels by Age Distribution

Variables	Categories	Participant			
		Percentages %	Happy	Moderately Happy	Unhappy
Age	18-24	11,5	56,1	33,5	10,4
	25-34	19,7	54,7	32,6	12,7
	35-49	31,6	52,0	35,2	12,8
	50-64	22,9	50,4	35,2	14,4
	65 +	14,3	59,9	29,4	10,7

When the happiness levels are examined according to the age distribution, it is seen that the happiest group is the individuals over the age of 65. (59.9%) In this age range, a generalization may occur as the anxieties of individuals do not appear in life. In addition, when the levels of unhappiness are examined, the highest level is the 50-64 age group (14.4%). Afterwards, when the levels of unhappiness are examined, it is seen that the age range of 25-34 and 35-49 is approximately the same. If a generalization is made especially for the 25-34 age range (12,7), it can be concluded that various reasons such as problems in life and anxiety about finding a job increase.

#### 4.3.4. Happiness Levels by Educational Status

Considering the education levels, it is seen that the happiest group is 57.1% of the individuals in the category of those who have not completed a school. However, as the level of education increases, the happiness rate decreases. The reason for this can be expressed as that with the increase in the education level of the individuals, their expectations in life will increase in the same way and unhappiness will arise when faced with the reason that it does not result.

Happiness levels by Educational Status are shown in Table 4.

Table 4. Happiness Levels by Educational Status

Variables	Categories	Happy	Moderately Happy	Unhappy
Education Status	Out of School	57,1	28,1	14,8
	Primary school, primary education	53,2	33,8	13,0
	Vocational Secondary School	53,5	34,0	12,5
	Vocational High School	52,0	36,1	11,9
	High education	54,5	34,6	10,9

#### 4.3.5. Happiness Levels by Industry

Table 5. Happiness Levels by Industry

Variables	Categories	Happy	Moderately Happy	Unhappy
Industry	Private sector	50,4	36,7	12,9
	Public sector	57,0	35,1	7,9

Happiness levels according to the sector they work in are shown in Table 5. Considering the level of happiness according to the sector in which they work, the happiest group is the employees in the public sector, which is 57.0%. Looking at the employees in the private sector, it can be stated that 50.4% are happy. According to this result, although the private sector salary is higher, it can be said that the reason for happiness differs due to difficult and tiring conditions.

#### 4.3.6. Happiness Levels by Health Status

It is seen that the individuals with the highest level of happiness according to their health status are those who state their health status as very good 67.6%. On the other hand, as the health status of the individuals is poor, the level of happiness of the individuals decreases, and in parallel, the individuals with the highest level of unhappiness are those who state their health status as "very bad" 47.9%.

Happiness levels by Health Status are shown in Table 6.

Table 6. Happiness Levels by Health Status

Variables	Categories	Happy	Moderately Happy	Unhappy
Health Status	Very good	67,6	28,1	4,3
	Good	60,5	30,4	9,0
	It will do	41,4	45,6	13,0
	Bad	35,7	34,7	29,6
	Too bad	24,3	27,8	47,9

#### 4.4. Assumptions of Sequential Regression Analysis

The results of the models of the data are shown by the ordinal logistic regression analysis. It was observed that the validity of the parallel lines assumption was ensured when the model's assumption was applied.

##### 4.4.1. Examining the Model's Goodness of Fit

The goodness of fit of the model can be found by using Chi-Square and Deviation values. These values of the model are indicated in the table.

Table 7. Goodness of Fit Test Results

	Chi-Square	Sd	Possibility
Pearson	7558,125	7602	,637
Deviation	6411,631	7602	1,000

$H_0$ : Model data is OK.

$H_1$ : Model data is not available.

Considering the results of the model's goodness-of-fit analysis, the probabilities are greater than 0.05. In line with these results, the  $H_0$  basic hypothesis, in which the model is in harmony, cannot be rejected. As a result, the model has goodness of fit.

#### 4.4.2. Parallelism Assumption Test

The setup of " $H_0$  null hypothesis" and " $H_1$  alternative hypothesis" in testing the parallel curves assumption is as follows.

- **$H_0$** : The associated regression coefficients are the same in all categories of the dependent variable.
- **$H_1$** : The associated regression coefficients are different in all categories of the dependent variable.

Table 8. Parallelism Test

Model	-2 Log Likelihood	Chi-Square	Sd	Possibility
Basis Hypothesis	221,358			
General	189,561	31,797	27	,240

**$H_0$** : Parameter estimates pass through the same breakpoint.

**$H_1$** : Parameter estimates do not pass through the same breakpoint.

Since  $p > 0.05$ ,  $H_0$  cannot be rejected and in this case, it is expressed in all categories of parameters where the dependent variable, satisfaction, is equal to each other. Thus, the situation can be stated about the suitability of the model established after the assumption is made.

#### 4.4.3. Evaluation of Goodness of Fit with Pseudo $R^2$ Values

The goodness of fit of the model, in which the percentage of the dependent variable is explained by the independent variables, was examined through  $R^2$ . However, since  $R^2$  results are not a good criterion in Logistic Regression, these analyzes are low.

Table 9. Pseudo (Pseudo)  $R^2$  Goodness of Fit Test Results

CoxandSnell	,237
Nagelkerke	,278
McFadden	,140

Looking at the results, the Cox and Snell  $R^2$  value is 0.237, while the Nagelkerke  $R^2$  value (0.278), which is used to eliminate the limitation, is slightly higher. In addition to these, McFadden  $R^2$  has a value of 0.140.

#### 4.4.4. Interpretation of the Model's Parameter Estimates

To interpret the independent variables in the model, the probability (p) values in the variables are checked. There are 5 variables in the model, which are marital status, employment status, health status, income status and satisfaction with social life. Values of these probability values less than 0.05 are statistically significant variables. The values of the significant variables belonging to the Wald Test and the significance tests of the parameters are used.

SPSS does not give odds ratios in ordinal regression analysis. In order to interpret the parameter values, which are "interpretation according to the odds ratio", the values are interpreted by taking the odds values as "e prime" in excel. Interpretations are made by determining the reference category (0a) in the results. According to the determined reference category, the interpretation of the variable to other categories is done. In Table 10, the estimation values of the parameters of the model, the probability (p) values and the odds ratio "e prime" values are shown. The results were interpreted according to the odds ratio values. Odds ratio can be between 0 and infinity, it cannot be less than zero due to its formula.

When the odds ratio is less than 1, the probability relative to the reference category has a reducing effect. When the odds ratio is greater than 1, the probability relative to the reference category has an increasing effect.

Table 10. Estimated Values of the Parameters of the Model

Variables	Coefficient ( $\hat{\beta}$ )	Standard error	Wald	Sd	Odds Oranı ( $e^{\beta}$ )	Probability (p) value
<b>Dependant Variables</b>						
[Happiness =1]	-4,296	,319	180,828	1		,001
[Happiness =2]	-2,056	,316	42,285	1		,001
<b>Independent Variables</b>						
[Marital status =1]	,024	,109	,050	1		,822
[Marital status =2]	-,531	,093	32,542	1	<b>0,588</b>	<b>,001</b>
[Marital status =3]	,538	,146	13,567	1	<b>1,712</b>	<b>,001</b>
[Marital status =4]	0 <sup>a</sup>	.	.	0		.
[Working Status =1]	-,044	,052	,713	1		,398
[Working Status =2]	,300	,382	,616	1		,432
[Working Status =3]	0 <sup>a</sup>	.	.	0		.
[Health situation =1]	1,587	,199	63,468	1	<b>4,891</b>	<b>,001</b>
[Health situation =2]	1,223	,177	47,530	1	<b>3,399</b>	<b>,001</b>
[Health situation =3]	,906	,181	25,167	1	<b>2,475</b>	<b>,001</b>
[Health situation =4]	,610	,184	10,921	1	<b>1,840</b>	<b>,001</b>
[Health situation =5]	0 <sup>a</sup>	.	.	0		.
[Income status =1]	1,361	,198	47,237	1	<b>3,902</b>	<b>,001</b>
[Income status =2]	1,250	,109	131,345	1	<b>3,491</b>	<b>,001</b>
[Income status =3]	,787	,110	50,882	1	<b>2,197</b>	<b>,001</b>
[Income status =4]	,362	,105	11,888	1	<b>1,436</b>	<b>,001</b>
[Income status =5]	0 <sup>a</sup>	.	.	0		.
[Social life =1]	1,440	,198	53,015	1	<b>4,222</b>	<b>,001</b>
[Social life =2]	1,313	,121	117,584	1	<b>3,717</b>	<b>,001</b>
[Social life =3]	,859	,123	48,784	1	<b>2,360</b>	<b>,001</b>
[Social life =4]	,541	,119	20,767	1	<b>1,719</b>	<b>,001</b>
[Social life =5]	0 <sup>a</sup>	.	.	0		.

According to the data of the independent variables in Table 10, it is seen that certain categories of 4 independent variables out of 5 independent variables yield significant results. The categories that are significant out of these 4 variables will be interpreted, and the non-significant working status variable will not be interpreted. The first argument to be interpreted is the "marital status" variable.

**Marital Status:** When the chart is examined, the reference category is "His wife died". Significant categories should be interpreted according to this category. It is concluded that individuals who give the answer "married" to this question are 0.58 times happier than those who answer "his wife is dead", and individuals who answer "divorced" are 1.71 times happier than those who do not give the same answer.

**Health Status:** When the chart is examined, it is seen that the reference category has a category that gives the answer "very bad". Therefore, meaningful categories are interpreted according to this reference category. Here, individuals with "very good" health status are approximately 5 (4,89) times happier than individuals who answer "very bad". In the next stage, individuals who gave the answer "good" were 3.39 times happier than those who stated "very bad" health status, and those who gave the answer "moderate" were 2.47 times happier than the same individuals. The conclusion to be drawn from this situation is the expected and consistent result, since the happiness levels of the individuals are higher than the individuals with "very poor" health status, the better the health status.

**Income Status:** In terms of income, it is seen that the reference category has a category that gives the answer "very bad". Meaningful categories are interpreted according to this reference category. Here, individuals with a "very good" income status are approximately 4 (3.90) times happier than those who answer "very poor". The second category is 3.49 times happier than the individuals whose income status

is "very bad" and those who answer "moderate" are 2.19 times happier than the same individuals. Individuals in the last category "bad" are 1.43 times happier than individuals who give the same answer. As a result, it is seen that happiness levels increase when the income is good.

**Social Life:** It is observed that individuals whose reference category is in the variable "not satisfied at all" have 4.22 times more happiness than individuals who are "very satisfied". Those who are "satisfied" are 3.71 times happier, and individuals who give the answer "moderate" are 2.36 times happier than those who give the same answer. According to these results, it is seen that those who are satisfied with their social life, entertainment, cultural and sports activities are happier.

## 5. Conclusion

Life satisfaction survey is a research conducted by TUIK on individuals aged 18 and over to measure individuals' perspectives on events. It aimed to measure individuals' happiness levels, general life satisfaction, satisfaction with health, education, public services, social security, justice, public order, transportation and municipal services. Based on the data set, in the thesis study, the variables of life satisfaction and future expectation of individuals were examined and interpreted with ordinal (sequential) regression analysis.

Based on the results of the analysis in the study, according to gender, women are happier, individuals who are married in marital status are happier, and when it is categorized by age distribution, the happiness levels of individuals over the age of 65 are higher. It has been concluded that individuals with good income status are happier. As a result of the descriptive statistics of the variables, it is seen that the individuals generally feel happy. It has been seen that health and family are the most sources of happiness in life. In addition, being in good health is one of the determining factors of happiness. Other factors affecting the life satisfaction of individuals are health services, education services, public order services and transportation services, which are public satisfaction levels.

In the study, life satisfaction of individuals is one of the most important factors that increase life satisfaction with their gender, age, marital status, education status, monthly income, as well as their social life and good health status.

Based on these results, it has been seen that the happiness level of individuals is generally high. According to TUIK survey data, women are happier than men. According to another variable marital status, married individuals were found to be the happiest. It has also been observed that individuals aged 65 and over are the happiest. Happiness in education level, on the other hand, increased the level of unhappiness with the effect of the expectation on the individual. It is seen that happiness increases in those who have a good increase in income status.

Education, health, income status, satisfaction in social life and public services are the most important factors in line with the work that affects the life satisfaction and quality of individuals. In the light of these studies; Individuals with very good health status are more happy than individuals with health problems. These problems affect various problems and quality of life.

As a result, the improvement of the health conditions of the individuals, the access to health services and the increase in the opportunities will allow the quality and life satisfaction of the individuals to be higher. The same conditions cover education status and education services and other services. Increasing the level of education and educational services received will enable individuals to advance their own development and pave the way for the achievements to be achieved.

Income status and working status are also important factors affecting life satisfaction of individuals. The fact that individuals can have and receive the opportunities they want, their comfort in working situation significantly affects their quality of life. Therefore, further improvement of income levels and working conditions will be of great importance in increasing life satisfaction.

As a result, in the analysis findings; It has been concluded that the demographic characteristics and time can change the satisfaction with the demographic characteristics, as well as the health status, education and income status are statistically significant in terms of life satisfaction.

In general, the aim of this thesis is to determine the levels and situations that affect the life satisfaction of individuals and to determine new approaches and to aim to reach the theoretical studies to a higher level.

### Contribution of Researchers

All researchers have contributed equally to writing this paper.

### Conflicts of Interest

The authors declare no conflict of interest.

### References

- [1] Neugarten, B. L. (1961). Life satisfaction and social interaction in the aging. *Journal of Gerontology*, 16, 344–346.
- [2] TÜİK. (2019). Yaşam Memnuniyeti Araştırması Mikro Veri Seti Life Satisfaction Survey 2019. <http://library1.nida.ac.th/termpaper6/sd/2554/19755.pdf>
- [3] Ülker Tümlü, G. ve Receptoğlu, E. (2013). Üniversite Akademik Personelinin Psikolojik Dayanıklılık ve Yaşam Doyumu Arasındaki İlişki. *Yükseköğretim ve Bilim Dergisi*, 3(3), 205–213. doi:10.5961/jhes.2013.078
- [4] Veenhoven, R. (2000). The Four Qualities Of Life Ordering concepts and measures of the good life. *Annals of Operations Research*, 97(1–4), 131–141. doi:10.1023/A
- [5] DolgunNA, Saraçbaşı O. Lojistik Regresyon Çözümlemesi. Ankara: Hacettepe Üniversitesi Yayınları; 2015.
- [6] Alpar R. Uygulamalı Çok Değişkenli İstatistiksel Yöntemler. Ankara: Detay Yayıncılık; 2017.
- [7] Gürsakal, S. ve Öngen, K. B. (2008). 2007 Yaşam Memnuniyeti Anketinin İstatistiksel Yöntemler İle Analizi. *Uludağ Üniversitesi İktisadi ve İdari Bilimler Fakültesi Dergisi*, 27(1), 1–14.
- [8] Kahyaoğlu, O. (2008). Yaşam Memnuniyeti Ve Yaşam Memnuniyetini Etkileyen Değişkenler İle Ekonometrik Uygulama: Türkiye Örneği. *Dokuz Eylül Üniversitesi*.
- [9] Akın, H.B.ve Şentürk, E. (2012). “Bireylerin Mutluluk Düzeylerinin Ordinal Lojistik Regresyon Analizi İle İncelenmesi”, *Öneri Dergisi*, 10: 183- 193.
- [10] Dursun, S. ve İftar, E. (2014). Kadın Çalışanların Yaşamış Oldukları İş Aile Yaşamı Çatışmasının İş ve Yaşam Doyumu Üzerine Etkisi. *Atatürk Üniversitesi İktisadi ve İdari Bilimler Dergisi*, 3, 127–137.
- [11] Filiz, Z., (2014). An Analysis of the Levels of Job Satisfaction and Life Satisfaction of the Academic Staff. *Social Indicators Research*, vol.116, no.3, 793-808.
- [12] Arı, E. ve Yıldız, Z. (2016). Bireylerin Yaşam Memnuniyetini Etkileyen Faktörlerin Sıralı Lojistik Regresyon Analizi ile İncelenmesi *Uluslararası Sosyal Araştırmalar Dergisi The Journal of International Social Research*, 9(42), 1362–1374. [www.sosyalarastirmalar.com](http://www.sosyalarastirmalar.com) adresinden erişildi.
- [13] Proctor, C. L., Linley, P. A. ve Maltby, J. (2009). Youth life satisfaction: A review of the literature. *Journal of Happiness Studies*. Doi:10.1007/s10902-008-9110-9
- [14] Beşel, F. (2015). 2013 Yılı Yaşam Memnuniyeti Araştırması Sonuçlarının İl Bazlı Ekonomik, Sosyal ve Siyasi Analizi. *Karabük University Journal of Institute of Social Sciences*. doi:10.14230/joiss102
- [15] Schyns, Peggy (2002), “Wealth of Nations Individual Income and Life Satisfactionin 42 Countries: A Multilevel Approach”, *Social Indicators Research*, Vol; 60, 5-40.
- [16] Ramachandran, Rathi and Radhika R (2012), “SocioEconomic Statüs, Life Satisfaction in Cross Culturel Perspective: The Elderly Japan and India”, *International Journal of Humanities and Social Science*”, Vol; 285-292.
- [17] Emeç, H. (2002). Ege Bölgesi Tüketim Harcamaları İçin Sıralı Logit Tahminleri ve Senaryo Sonuçları. *Dokuz Eylül Üniversitesi Sosyal Bilimler Enstitüsü Dergisi*, 4(2), 13–29.
- [18] Chen, C.-K. ve Hughes Jr., J. (2004). Using Ordinal Regression Model to Analyze student satisfaction questionnaires. *Association for Institutional Research*, 1, 1–12.
- [19] Ayhan, S. ve Yıldız, Z. (2006). Sıralı Lojistik Regresyon Analiziyle Türkiye’deki Hemşirelerin İş Bırakma Niyetini Etkileyen Faktörlerin Belirlenmesi. *Osmangazi Üniversitesi, Fen Bilimleri Enstitüsü Yüksek Lisans Tezi*.

- [20] Nizam, D. K. ve Akdeniz, H. A. (2008). Türkiye 'de Yataklı Tedavi Kurumlarının Kategorize Edilen Yatak Kapasitelerinin Sıralı Lojistik Regresyon Analizi. Dokuz Eylül Üniversitesi Sosyal Bilimler Enstitüsü Dergisi, 10(4), 1–18.
- [21] Demirtaş, E. A., Anagün, AS. ve Köksal, G. (2008). Mutfak Armatürü Tasarımının Kullanıcıların Görsel Algılarına Göre Lojistik Regresyon Yoluyla Belirlenmesi. Endüstri Mühendisliği Dergisi, (7),17–31.
- [22] Das S ve Rahman RM. (2011). Application of ordinal logistic regression analysis in determining risk factors of child malnutrition in Bangladesh. Nutrition Journal, 1–11.
- [23] Yavuz, S., Deveci, M., Karabulut, T. ve Şentürk, E. (2013). Sıralı Lojistik Regresyon Analiziyle Üniversite Öğrencilerinin Kent Memnuniyetini Etkileyen Faktörlerin Belirlenmesi: Erzincan Üniversitesi Örneği. Cumhuriyet Üniversitesi İktisadi ve İdari Bilimler Dergisi, 15(1), 95–114
- [24] Yakut, E., Gündüz, M. ve Demirci, A. (2015). İnsani Kalkınmışlık Düzeyinin Sınıflandırma Başarılarının Karşılaştırılmasında Sıralı Lojistik Regresyon Analizi ve Yapay Sinir Ağları Yöntemlerinin Kullanılması. Journal of Business Research- Turk, 7(4), 172–172. doi:10.20491/isader.2015415532
- [25] Tunalı, D. ve Aytakin, A. (2017). Öyp Araştırma Görevlilerinin Yaşam Doyumlarının İkili Lojistik Regresyon Analizi İle İncelenmesi. International Journal of Management Economics and Business, 13(31), 0–0. doi:10.17130/ijmeh.20173126273
- [26] Usta, H. G., Ugurlu, C. T. ve Simsek, A. S. (2016). Üniversite Öğrencilerinin Devamsızlık Tutumları: Değişkenler Arası Lojistik Yordayıcılık. International Journal of Social Science, 169–182.



# Forecasting Probability of Risk Sea Accident With Machine Learning

Ragıp ZİLCİ<sup>1\*</sup>, Hakan AKYOL<sup>2</sup>

<sup>1</sup>Industrial Engineer, Ankara, Türkiye; ORCID: [0000-0002-8996-0213](https://orcid.org/0000-0002-8996-0213)

<sup>2</sup>Çankaya University, Graduate of School of Natural and Applied Sciences, Ankara, Türkiye; ORCID: [0000-0002-5695-8790](https://orcid.org/0000-0002-5695-8790)

\* Corresponding Author: [zilciragp@gmail.com](mailto:zilciragp@gmail.com)

Received: 17 September 2022; Accepted: 18 December 2022

**Reference/Atf:** R. Zilci, H. Akyol, “Forecasting Probability of Risk Sea Accident With Machine Learning”, Researcher, vol. 02, no. 02, pp. 73-80, Dec. 2022, doi:10.55185/researcher.1206498

## Abstract



The main aim to be achieved in this study is to develop a system that can predict maritime accidents and raise awareness about preventing these accidents or taking precautions before these painful experiences occur. In this study, naval trade routes and marine transportation, which constitute the essential building block of world trade, have been the biggest problem for years; It is aimed to examine the leading causes of maritime accidents/incidents that have caused death, injury, and all kinds of losses by shedding light on—in this context, classifying the maritime accidents/incidents will investigate which types of naval accidents may occur for which reasons. The study is aimed to predict the probabilities of sea accidents that may happen in the future with the help of a data set consisting of information on previous years' maritime accidents, with the use of a model trained with machine learning methods. The machine learning model in question will be developed through the python software language, based on various Supervised Machine Learning algorithms and Artificial Neural Networks (ANN). The main aim to be achieved in this study is to develop a system that can predict maritime accidents and to raise awareness about preventing these accidents or taking precautions before these painful experiences occur.

**Keywords:** machine learning, artificial neural network, sea accident, binary classification

## 1. Introduction

In this study, maritime trade routes and maritime transportation, which constitute the essential building block of world trade, have been the biggest problem for years; It is aimed to examine the leading causes of maritime accidents/incidents that have caused death, injury, and all kinds of losses by shedding light on. In this context, it will be investigated what kind of reasons the said maritime accidents/incidents may occur. As a result of this research, the causes of marine accidents will be determined as a reference point in estimating the probability of future maritime accidents. They will have an importance that forms the basis of the study. The reason for this importance arises from the fact that the examination of the maritime accidents of the past years is based on the determination of the condition of the ships involved in the said accidents in terms of the causes of the marine accidents investigated. The methodology above aims to train a data set consisting of information on previous years' maritime accidents, the model to be developed with machine learning methods, and to predict the possibilities of sea accidents that may occur in the future with the help of this model. The machine learning model in question will be developed through the python software language based on various Supervised Machine Learning algorithms and Artificial Neural Networks (ANN). The data obtained as a result of the study will be tested with data that has not been introduced to the model for training purposes before, and the estimation performance probability of the model, in other words, “Accuracy” values, will be revealed with the statistics formed as a result of the test data. In this way, it is evaluated that before a ship embarks on any sea voyage, when it is examined in terms of the criteria previously determined as the leading causes of maritime accidents, it is considered that an idea can be obtained about how ready it is for this voyage. The main aim to be achieved in this study is to develop a system that can predict maritime accidents and raise awareness about preventing these accidents or taking precautions before these painful experiences occur. The study aims to improve its scope by taking it as a reference in future studies in this field, to perform statistical analysis and interpretation of the data, to compare the machine learning models used, to search for the best model, and to produce estimates closer to actual results with more precise calculations of the estimation probability, etc. maintenance can be improved.



## 2. Problem Definition

According to the Regulation on Investigation and Investigation of Marine Accidents and Incidents, maritime accidents include "Death or injury of a person, loss of a person while on the ship, sinking, loss, loss or abandonment of the ship, material damage to the ship, inability of the ship to maneuver, the ship running aground, and occurring in connection with the operations and activities of a ship, It is defined as "an event or series of events that results in the occurrence of serious environmental pollution resulting from the damage of the ship or ships, or the emergence of the possibility of serious environmental pollution" [1].

A Marine incident is defined as "an event or series of events other than a maritime accident that occurs in connection with the operations and activities of a ship and which endanger the safety of the ship, people on board or other persons, or the environment, or which, if not corrected, may endanger it" [1].

Maritime accidents, human deaths, and injuries, in addition to the direct damages of millions of dollars to the country's economy, create pollution in the sea and indirectly cause harmful effects on the deterioration of the ecological balance and world trade and global ecological balance [2]. For this reason, it is essential to prevent maritime accidents before they occur.

In this context, proper classification and storage of past accident data, scientific analysis, and estimation of ships that are likely to cause marine accidents/incidents in the future are of great importance in preventing accidents [3].

## 3. Related Works

When a maritime accident/incident is mentioned, the first thing that comes to mind is search and rescue activities. The Main Search and Rescue Coordination Center under the Ministry of Transport and Infrastructure is responsible for the general coordination of search and rescue activities in our country [3]. Records of maritime accidents and other incidents in the Turkish search and rescue region are kept by The Main Search and Rescue Coordination Center, and descriptions of accidents/incidents are publicly published on the institution's official website [3]. When the previous records are examined, it is seen that a total of 2058 maritime accidents/incidents took place in the Turkish search and rescue region only between 2012 and 2019, as presented in Table 1 [4].

Table 1: Number of Marine Accidents/Incidents in the Turkish Search and Rescue Zone Between 2012-2019.

Year	Total Number of Accidents/Incidents
2019	634
2018	238
2017	277
2016	504
2015	68
2014	96
2013	106
2012	135

It is also possible to come across various studies in the literature in which different samples from different periods are analyzed using The Main Search and Rescue Coordination Center accident/incident data. For example, In a study examining the relationship between the ships involved in the accident on the Bosphorus between 1982 and 2014 and the presence of a pilot on the ship, the rate of having a pilot was 21.6% in all ships involved in the accident during the specified period, "having a pilot reduces the accidents" and It was stated that the ships that did not hire a pilot were involved in the most accidents in the said period [3].

Again, in some of these studies, "the rate of occurrence of maritime accidents according to their types, the rate of occurrence according to the seasons, the distribution according to the time of the accident, the distribution according to the types, tonnage, and length of the ships involved in the accident" were examined. The results were analyzed statistically [3].

In another study, it was stated that human errors and these errors cause 95% of maritime accidents/incidents are "undetected errors due to workload, situational awareness, ergonomics of the working environment, and lack disciplined and regular training" [5]. For this reason, in this study, systems that can provide fully autonomous management of ship systems and routes are proposed to minimize human errors [5].

The continuation of all these studies investigating the causes of maritime accidents and questioning what kind of solutions can be developed by analyzing them statistically will significantly contribute to reducing marine accidents. A study that proposes to produce solutions using machine learning methods in the field of artificial intelligence on this subject has yet to be found during the literature search due to the effect of artificial intelligence being a newly developing technology.

This study that we will prepare, while adding a new one to the reflections in the fields of machine learning and deep learning in the prevention of maritime accidents, it is aimed to take a step to use machine learning more frequently in the prevention of marine accidents.

#### 4. Dataset Description

Records of maritime accidents/incidents occurring within the borders of the Turkish search and rescue zone are kept by The Main Search and Rescue Coordination Center of the Ministry of Transport, Maritime Affairs, and Communications and on the official website (<http://aakkm.udhb.gov.tr/>) It is publicly published in the "Accident/Incident Statistics" section. However, since the information on the ships involved in maritime accidents/incidents is entirely lacking in the records on the website of The Main Search and Rescue Coordination Center, some of the reasons leading to the occurrence of maritime accidents/incidents are defined as variables within the framework of the literature review mentioned in the previous section. A data record form was designed in which the data was recorded according to the system (0: Worst Case – 10: Best Case). It would be appropriate to give the points to be written for the subjective data in the registration above form by the supervisors who are experts in the subject by accurately observing the condition of the ship in related matters before the voyage.

This study, since it is aimed to evaluate the models in which effective results can be obtained on this type of problem, using the data above record form- considering that the reasons learned to cause the most common marine accident/incidents within the scope of the literature review may have a more significant impact on the probability of accident/incident occurrence - imaginary data has been created. The data registration form in question is presented in Table 2.

Table 2: Data Registration Form Sample Data.

Human Causes (Give a Score Between 0 and 10)				Other Causes				Accident Occurrence Status (1: Yes/ 0: No)
Comfort in Workload	Situational Awareness	Working Environment Ergonomics	Education and Discipline	Navigator (Yes-No)	Ship Age (0+)	Ship Tonnage	Ship Capacity/Load Ratio (%)	
7	3	4	7	1	44	1449	0,289	0
3	3	3	3	1	48	4126	0,760	1

Summary information about the data generated using the data above recording form is presented in Table (3-5).

Table 3: Data for the First 5 Rows in the Data Set.

Comfort in Workload	Awareness	Ergonomics	Education	Navigator	Ship Age	Tonnage	Ship Capacity	Accident
9	10	10	0	1	27	2947	0,005	0
2	3	4	1	0	57	2561	0,178	1
1	0	10	9	0	20	2767	0,423	1
2	6	0	1	1	55	3012	0,926	1
9	7	3	5	1	9	1399	0,956	0

Table 4: Mean, Standard Deviation, Min. and Max. Values.

	Count	Mean	Std	Min	25%	50%	75%	Max
Comfort in Workload	500	4,872	2,998	0,000	2,000	5,000	7,000	10,00
Awareness	500	5,044	3,106	0,000	2,000	5,000	8,000	10,00
Ergonomics	500	5,046	3,231	0,000	2,000	5,000	8,000	10,00
Education	500	4,724	3,167	0,000	2,000	5,000	7,000	10,00
Navigator	500	0,532	0,499	0,000	0,000	1,000	1,000	1,000
Ship Age	500	29,87	17,98	0,000	14,75	28,00	47,00	60,00
Tonnage	500	2563	1412	30,00	1304	2571	3776	4997
Ship Capacity	500	0,507	0,291	0,004	0,238	0,506	0,760	0,9986
Accident	500	0,636	0,482	0,000	0,000	1,000	1,000	1,000

Table 5: Correlation Matrix.

	Comfort in Workload	Awareness	Ergonomic	Education	Navigator	Ship Age	Tonnage	Ship Capacity	Accident
Comfort in Workload	1,000	-0,001	0,055	0,022	-0,096	-0,015	0,011	0,009	-0,274
Awareness	-0,001	1,000	-0,084	-0,006	-0,008	-0,054	0,054	-0,024	-0,241
Ergonomics	0,055	-0,084	1,000	-0,036	-0,014	0,067	0,046	0,001	-0,247
Education	0,022	-0,006	-0,036	1,000	-0,074	-0,014	-0,067	0,036	-0,632
Navigator	-0,096	-0,008	-0,014	-0,074	1,000	-0,009	0,077	-0,074	-0,068
Ship Age	-0,015	-0,054	0,067	-0,014	-0,009	1,000	0,004	-0,814	0,024
Tonnage	0,011	0,054	0,046	-0,067	0,077	0,004	1,000	0,003	0,115
Ship Capacity	0,009	-0,024	0,001	0,036	-0,074	-0,814	0,003	1,000	0,006
Accident	-0,274	-0,241	-0,247	-0,632	-0,068	0,024	0,115	0,006	1,000

The correlation matrix is a matrix that shows the extent to which the variables of the data are related to each other. The results obtained from the experiments can generally be compared with the correlation matrix, and it can be interpreted how significant the results are. In this study, no problems were detected regarding the relationship criteria of the data on the correlation matrix. In particular, the results of the Univariate Linear Regression experiments were examined and checked in terms of the effect of each variable on the dependent variable  $y$  (0-1), which indicates the occurrence of the accident/incident. The results were evaluated to be significant.

It is essential to create a sensitive and real-time data recording infrastructure to produce models that give healthier and more accurate results in data science projects that will be studied in this and many similar areas in our country and to complete the digital data transformation in the areas needed to increase the acceleration in technological development without harming the principle of confidentiality of private and personal information. offers<sup>1</sup>. The data registration form designed in this study will shed light on this issue.

This scope of work;

- Comfort in Workload,
- Situational Awareness at Sea,
- Working Environment Ergonomics,
- Education-Discipline,
- Navigator,
- Age of Ship,
- Ship's Tonnage,

<sup>1</sup> Creating the data recording infrastructure and the digital data transformation project is necessary for technological development. However, when this project is carried out, a meaningless result will emerge, considering that the technical goal to be achieved is to make people's lives more accessible when the privacy of personal information and the private rights and freedoms of the person being harmed. Although this issue should be emphasized, many ongoing studies exist on the ethical use and legal binding of artificial intelligence.

- Ship's Capacity/Load Ratio

According to the eight variables examined in terms of their causes, the occurrence of accident/incident at sea Experiments were carried out on 500 pieces of data indicating (0: The Accident Did Not Occur, 1: The Accident Occurred).

## 5. Proposed Approach

The problem examined in the study (0-1) involves estimating the binary dependent variable. To get successful results in the study, we need to reach the most suitable machine-learning algorithm for our problem. In this context, to understand the model we want to go, we should examine the algorithms and their usage areas within the scope of machine learning. Machine learning algorithms are generally divided into four groups according to the functions they provide [6]. These are supervised, unsupervised, semi-supervised, and reinforcement learning [6]. Unsupervised learning methods are generally applied for problems where the groups in the data set are unknown, and the data is unlabeled. In semi-supervised learning, a tiny part of the data is labeled, but the remaining data is marked by using the labeled data in question. Thus estimation or classification processes are made on the corrected data set.

Reinforcement learning falls into a completely different scope. Although they have similar aspects to supervised and unsupervised learning, they also have other aspects. Reinforcement learning is applied to the problems in which the algorithm continues its learning process with the reward-punishment method over the given situations. An example is the definition of rewards and punishments as labeled data. The self-learning process of the algorithm can be compared to unsupervised learning methods. As a result, reinforcement learning models, simulation, games, etc. It is applied in areas with stochastic processes. The approach we will use in our study is the supervised machine learning approach. Supervised learning is that the data set consists of labeled data and regression, classification, estimation, etc., over these labeled data. It contains algorithms in which the operations are applied. For this reason, supervised machine learning models are considered appropriate for our problem labeled as (0-1) binary dependent variable.

Training data will be used to realize learning through the models to be created, and test data will be used to measure the performance of the developed models. In our study, data labeled as binary (0-1) were separated as 70% training and 30% test data. The models we compared in our study within the scope of supervised learning are presented in the following items.

- Univariate Linear Regression
- Multivariate Linear Regression
- Logistic Regression
- Gaussian Naive Bayes Classifier
- K-Neighbor Nearest – KNN
- Decision Tree Classifier
- Support Vector Classifier – SVC
- Random Forest Classifier
- Gradient Boosting Machines
- Artificial Neural Network – ANN

In the models mentioned above, linear methods such as linear regression and logistic regression were used, as well as nonlinear methods such as SVC. The mentioned methods are used for similar purposes (regression and classification) [7]. Which of these methods better expresses our data and performs better with fewer errors is presented in detail in the experiments and results section. In this context, as a result of the experiments, it has been determined that Artificial Neural Networks provide the best performance. For this reason, with the help of data trained using artificial neural networks for our current problem, it

will be possible to reveal how risky the said ship is in terms of marine accident/incident by estimating the data filled in on the data record form mentioned in the section of defining the data set before sailing.

## 6. Experiments and Results

The models above were created in the experimental phase using the "Keras" library and the "Python" software language. The coding in question was applied in the "Jupyter Notebook" environment. The results obtained as a result of the experiments are summarized in Tables 6 and 7.

- Root Mean Squared Error – RMSE<sup>2</sup> Evaluation of Linear Regression Models on the Metric:

Table 6: Linear Regression Models RMSE Values.

Variable	RMSE Value
$X_1$	0.463
$X_2$	0.467
$X_3$	0.467
$X_4$	0.373
$X_5$	0.480
$X_6$	0.481
$X_7$	0.478
$X_8$	0.481
$X_{1,4,5,7}$	0.338
$X_{All\ Attributes}$	<b>0.287</b>

• When the Table above is examined, it is seen that some variables have a more significant effect on the result; however, it is seen that no single variable contributes significantly to the development. Compared to the univariate models, a better error performance was obtained in the model created by combining the variables that affect the result the most. A better error performance was obtained in the multivariate linear regression model in which all variables were used. This shows that the probability of correct prediction will increase gradually as the number of variables explaining the data increases. For this reason, other models evaluated after this stage will be created using all variables.

- Accuracy Score<sup>3</sup> Evaluation of Other Models Used in the Study:

Table 7: Prediction Accuracy Performance by Models Used.

Model	Accuracy Score
Logistic Regression	85%
Gaussian Naive Bayes	84%
K-Neighbor Nearest – KNN	63%
Support Vector Classifier – SVC	64%
Decision Tree Classifier	83%
Random Forest Classifier	83%
Gradient Boosting Machines	86%
Artificial Neural Network – ANN	96%

<sup>2</sup> It is a quadratic metric that measures the magnitude of error often used to find the distance between the values predicted by a machine learning model and the actual values. The RMSE is the standard deviation of the estimation errors (residues). That is, residuals measure how far the regression line is from the data points; The RMSE measures how widespread these residues are. In other words, it tells how dense the data is around the line that best fits the data. RMSE value changes from 0 to  $\infty$  [7]. The formulation of the RMSE metric is presented below. In this context,  $P_i$  predicted values,  $O_i$  absolute values,  $I$ -related observation in the dataset, and  $N$  represents the total number of words in the data set.

$$RMSE = \sqrt{\frac{\sum_{i=1}^N (P_i - O_i)^2}{N}}$$

<sup>3</sup> Accuracy Score =  $\frac{True\ Negatives + True\ Positives}{True\ Negatives + False\ Negatives + True\ Positives + False\ Positives}$

- When the above Table is examined, it is seen that the KNN and SVC models perform poorly. Therefore they are not suitable for this problem. It is seen that the Decision Tree, Random Forest, Gaussian Naive Bayes, Logistic Regression, and Gradient Boosting Machines models, respectively, show progressively better (between 83%-86%) but average performance. It is seen that the best prediction performance- with a large margin- is obtained with artificial neural networks at 96%.

Finally, Multivariate Linear Regression Model and Artificial Neural Networks were compared in terms of the RMSE metric. Accordingly, the RMSE metric, which was found to be 0.28 in the Multivariate Linear Regression Model, was 0.2 with Artificial Neural Networks. In this context, it is seen that Artificial Neural Networks perform better than the Multivariate Linear Regression Model.

## 7. Conclusion and Discussion

An independent evaluation can be made in terms of a completely objective assessment by specifically storing the occupational accidents experienced by the Turkish flagged ships and the ship workers who are citizens of the Republic of Turkey in a foreign-flagged ship (as mentioned in this study by making use of the inspection scores to be made by an appropriate data record form and expert personnel). It is of great benefit to create an accident/incident database at sea across an occupational accident database so that scientific analyses can be made more quickly and healthily (by designing a system), thus minimizing work accidents.

This study it is aimed to analyze the risk of a possible marine accident/incident during the voyage of a ship, which will be evaluated in terms of various criteria before embarking on a maritime accident/incident dataset to be created. For this purpose, different supervised machine learning models and artificial neural networks were used. As a result of the experiments, the best performance was obtained with artificial neural networks. For this reason, the most suitable model among the other alternatives to the problem defined in this study is artificial neural networks.

In the future, the number of variables in the data set will be increased, and models that produce more inclusive and sensitive results on the problem will be developed. In addition, since the accuracy of the data to be obtained with the digital data transformation that will be developed nationwide over time, the predictions produced will be able to give more accurate results. In addition, the data set of the current problem can be expanded with the statistics of the accidents that occurred in a certain period and can be converted into time series data. In this context, prediction performance can be evaluated with the Long-Short-Term Memory (LSTM) model, a variation of Recurrent Neural Networks (RNN), within the scope of deep learning algorithms; however, by using Cross-Validation.<sup>4</sup> Method, the most realistic estimation performance of the selected model will be observed.

## Contribution of Researchers

All researchers have contributed equally to writing this paper.

## Conflicts of Interest

The authors declare no conflict of interest.

## References

- [1] Deniz Kazalarını ve Olaylarını Araştırma ve İnceleme Yönetmeliği, 2014: Madde 4.
- [2] "shorturl.at/hkDJK" adresli web sitesinin "Gemiler Zehir Saçıyor" başlıklı ve 30.01.2012 tarihli haberi.

---

<sup>4</sup>Cross-validation is a model validation technique that tests statistical analysis results on an independent data set [8].

- [3] “Türk Bayraklı Gemilerin Karıştığı Deniz Kazaları ve Denizcilere Etkilerine İlişkin Bir Analiz”, Fatih YILMAZ, Mustafa Necmi İLHAN, Mart 2018.
- [4] TC. Ulaştırma ve Altyapı Bakanlığının "[https://atlantis.udhb.gov.tr/istatistik/diger\\_deniz\\_kazalari.aspx](https://atlantis.udhb.gov.tr/istatistik/diger_deniz_kazalari.aspx)" adresli kurumsal web sitesi, son erişim tarihi 10.04.2021.
- [5] “Deniz kazalarında insan faktörü ve bir çözüm olarak e-seyir”, Bandırma Onyediy Eylül University, Mühendislik ve Doğal Bilimler Fakültesi, Ulaştırma Mühendisliği Bölümü, C.PENSE.
- [6] "<https://tr.wikipedia.org>" adresli web sitesi, son erişim tarihi 10.06.2021.
- [7] "<https://veribilimcisi.com/>" adresli web sitesi, son erişim tarihi 10.06.2021.
- [8] Kohavi, Ron (1995). "A study of cross-validation and bootstrap for accuracy estimation and model selection." Proceedings of the Fourteenth International Joint Conference on Artificial Intelligence. 2 (12). San Mateo, CA: Morgan Kaufmann. Ss. 1137-1143.



## Game Theory Applications in Disaster Management Research

**Pınar USTA<sup>1</sup>, Nesibe UYSAL<sup>2\*</sup>, Özgür BOZDAĞ<sup>3</sup>**

<sup>1</sup>Isparta University of Applied Science, Technology Faculty, Civil Engineering Department, Isparta, Turkey; ORCID: [0000-0001-9809-3855](https://orcid.org/0000-0001-9809-3855)

<sup>2</sup>Isparta University of Applied Science, Graduate School of Education, Civil Engineering Department, Isparta, Turkey; ORCID: [0000-0003-3277-517X](https://orcid.org/0000-0003-3277-517X)

<sup>3</sup>Dokuz Eylül University, Engineering Faculty, Civil Engineering Department, Izmir, Turkey; ORCID: [0000-0002-5389-5739](https://orcid.org/0000-0002-5389-5739)

\* Corresponding author: [nesibeuyosal80@gmail.com](mailto:nesibeuyosal80@gmail.com)

Received: 30 November 2022; Accepted: 13 December 2022

**Reference/Atıf:** P. Usta, N. Uysal, Ö. Bozdağ, "Game Theory Applications in Disaster Management Research", Researcher, vol. 02, no. 02, pp. 81-95, Dec. 2022, doi:10.55185/researcher.1212681

### Abstract



Natural disasters are sudden, dangerous events that affect nations and cause disasters in the human life. The research on effective planning and response to natural disasters is vital. Managing effective humanitarian operations is an important part of disaster management. Therefore, research on effective planning and response to natural disasters is quite important. In this paper, the literature on disaster management has been categorized. The studies on disaster management were examined using scopus and web of science databases. Statistical analysis of eligible studies selected according to keywords was made with the VOS viewer. As a result of the article analysis, it was seen that the articles on the subject decreased in the last 2 years, and the analyzes revealed that more studies should be done and that there is a work gap on the subject. It is aimed to present this study as a contribution to disaster management studies and literature.

**Keywords:** disaster, disaster management, game theory, data analysis, network

### 1. Introduction

The disaster causes enormous loss of life and property. Considering the disasters such as flood, tsunami, typhoon, earthquake and landslide in the past years, it is seen that serious damage has occurred in the regions where the said disasters occurred. It is quite important that the location of the disaster, its duration, the number of people affected, the extent of the damage, the location of the aid resources, and similar information are up-to-date and reliable in order to respond adequately and necessarily to the places where disasters occurred [1]–[3].

In recent years, frequent natural disasters and man-made catastrophic events have brought great loss to human beings. Any occurrence of natural disasters, such as earthquakes, typhoons, floods, or drought, cause huge property damage and human injuries [4]. Effective and rapid response to natural disasters is of great importance as many people are seriously affected by such events. Disaster response includes a range of activities that help minimize the impact of disasters, such as search and rescue operations, evacuation of affected people, food, water, medical aid. If these effectively planned interventions are not implemented in a timely manner, the situation will worsen for the survivors [5].

Disaster management involves a systematic approach to deal with natural and man-made disasters. The cycle of disaster management consists of four main phases: mitigation, preparation, response and recovery. Disaster Management Cycle is shown in Figure 1. If the stages are defined; The mitigation phase can be defined as long-term efforts to prevent disasters from occurring or to reduce their effects. Preparedness is the stage where various strategic (long-term) decisions and procedures are designed before a disaster occurs. The response phase includes operational decisions of relief supplies in affected areas after a disaster occurs, and finally the recovery phase can be defined as the activities undertaken to restore the previous condition of the affected areas.





Figure 1. Disaster Management Cycle

Duran et al. (2013) suggest three core stages of disaster relief management; The stages given in Figure 2.



Figure 2. Disaster relief management stages

Many studies have been carried out on disaster management and strategy formulation. Goli and Alinaghian (2017) investigated an indefinite integrated model was examined for the simultaneous location of temporary health centers in the affected areas, allocating the affected areas to these centers and determining routes to transport necessary goods [6]. Goli and Keshavarz (2022) examined a parallel machine queue dependent group scheduling problem was investigated in order to minimize the total weighted earliness and latency [7]. Goli et. al. (2019) were examined of this study is based on the application of a hybrid improved artificial intelligence and robust optimization and presenting a new method for calculating the risk of a product portfolio [8]. Goli et. al. (2021) were examined an integrated framework based on statistical tests, time-series neural networks, and improved MLP, ANFIS, and SVR with novel meta-heuristic algorithms in order to obtain the best prediction of demand for dairy products in Iran [9]. Goli and Malmir (2020) an optimization method based on reliability theory are designed and an allocation and routing model is presented for relief vehicles in areas affected by a disaster [10]. Goli and Muhammedi (2021) improved a new method the supply chain performance based on its sustainable strategies is proposed [11]. Tirkolae et. al. (2022) were developed a novel mathematical model to design a sustainable mask Closed-Loop Supply Chain Network (CLSCN) during the COVID-19 outbreak for the first time [12].

A well-designed disaster relief process should involve the following key activities, Relief process shown in Figure 3.

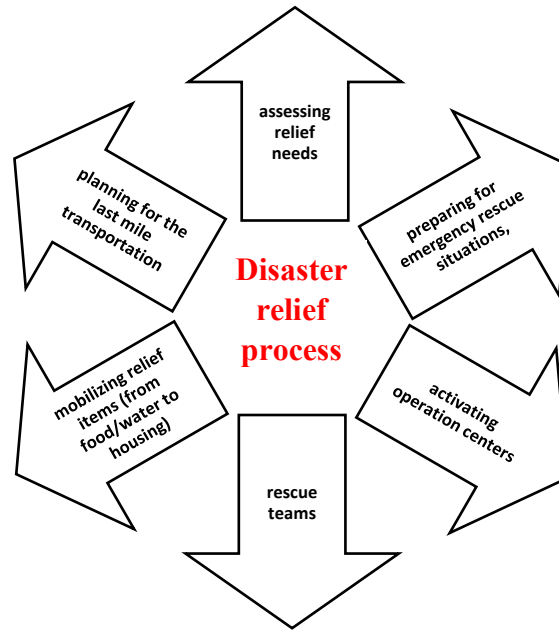

Figure 3. Disaster relief process [13].

Post-disaster management has different approaches and different priorities in countries. Different views and interpretations in countries also create differences in post-disaster management and strategies [14].

Game theory is concerned with the analysis of individuals strategies for overcoming competitive situations and is highly useful in a variety of applications [15].

One of the most important and urgent problems in post-disaster management is the supply of necessary materials to the disaster area. In most cases, supplies of essential goods enter the affected area from the nearest port or airport. Materials are then sent to a pre-warehouse near the affected area and delivered from that warehouse to a series of final warehouses. The aim here is to provide the right services and materials on time [16].

Although game theory is actively used in many areas, there is still very limited use of game theory approaches to disaster relief and management, but there is new literature. This article aims to draw attention to this gap by evaluating academic articles on game theory and disaster management with data sources and statistical analysis.

## 2. Game Theory

Game theory is a method derived from Mathematical Sciences where it is used in the competitive or collaborative position to find the most appropriate choices to lead to the desired outcome. Each game will feature at least two players who will walk to maximize their own interests in relation to the opponent's decision. In fact, it is becoming popular and interesting in some areas, such as economics, sociology, construction, politics and Management Sciences. In the areas mentioned, Game Theory can be used to predict the best outcome [17].

Typically, in game theory models, the "players" in the game are identified with their strategies, reflected by the variables they control, and the objective functions they individually try to optimize, often represented as utility functions. It depends on your strategies and the strategies of other players. Also, each player in the game has strategies that are subject to restrictions. There are non-cooperative games and cooperative games in which players compete with each other. In a sense, game theory problems and models are based on classical optimization models in which there is a single decision maker trying to determine an optimal solution given an objective function, variables, and constraints [18].

It shows new possibilities in solving problems encountered in disaster management situations with Game Theory applications. These are management and construction etc. They are initiatives aimed at providing maximum benefit in the conduct of their business [19].

Game theory makes it possible to simply model human behavior from a rational perspective and works according to a logic of equilibrium to achieve this [20].

### 3. Data source and statistical analysis

In this article, data from the Social Science Citation Index (SSCI) and the Science Citation Index Expanded (SCI-E) scopus base in the Web of Science database were used. Analysis search query is set to “TS = (Game theory) AND TS = (disaster or disaster management)”. The 1983 to 2021 interval has been determined as the research period. After the necessary adjustments were made, 1115 articles were left for analysis in the data set. Figure 4 shows the number of articles working on game theory and disaster.

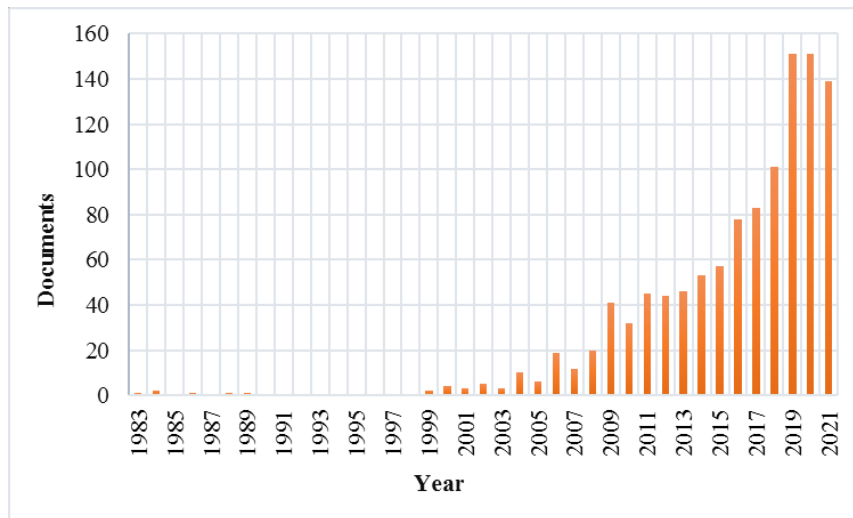

Figure 4. The number of articles working on game theory and disaster.

As seen in Figure 4; from 1999 to 2020, there has been an increase in the number of articles on this subject. The same number of (151 articles) was published in 2019 -2020. In 2021, this number is currently seen as 139. that is, there has been a decrease in the number of articles on the subject.

It can be thought that the reason for this decrease in this subject, which is still lacking in studies, in the last year, has recently turned the direction of scientists to look at a current issue, Covid-19.

In addition, when the percentage of articles published by fields is examined, it is seen that the articles in the field of engineering constitute 21.1% of the total number of newspapers, followed by the field of computers and mathematics. This shows that game theory and disaster issues have been studied extensively by scholars in this field. The Documents types by area is shown in Figure 5.

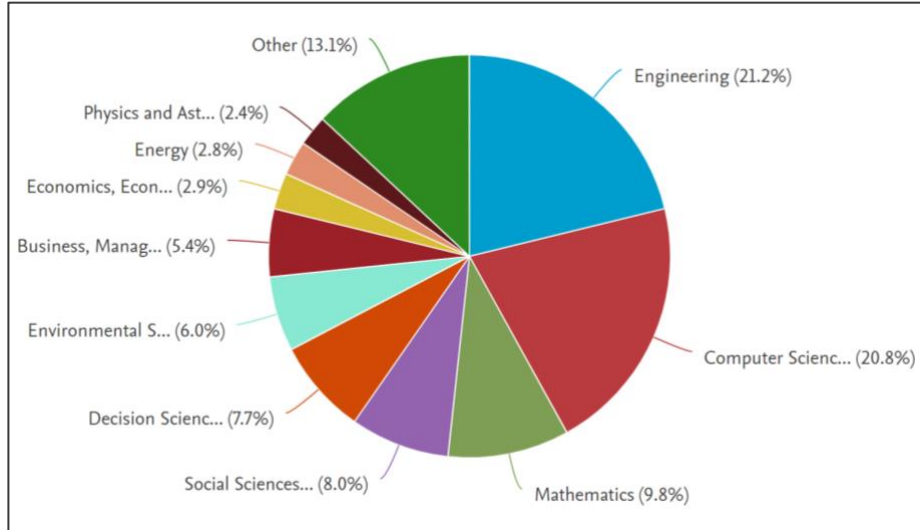

Figure 5. Documents types by area

#### 4. Data analysis

VOSViewer can be defined as a knowledge mapping tool for co-authoring and co-occurrence analysis. can create visual meshes with nodes and links in this tool. Nodes represent references, authors, and journals. Links show the relationship between nodes [21].

##### 4.1. Keyword co-Occurrence Analysis

Keywords represent the most important information about an article. Therefore, keyword co-occurrence network can be applied to analyze the research trend in the field of game theory. In the generated network, keywords are represented by nodes, the size of the nodes changes according to the frequency of keyword usage.

Depending on the keywords used in the articles and the frequency of their use in the same article group, the co-occurrence relationship between the keywords can be determined. Frequencies are taken into account in this analysis and accordingly a network of keyword co-occurrence is created.

The size of a node is positively correlated with the frequency of occurrence of the keyword, and each node in the network represents a keyword.

The keyword co-occurrence network created by VOSViewer as a result of the analysis are shown in Figures 6 to 8.

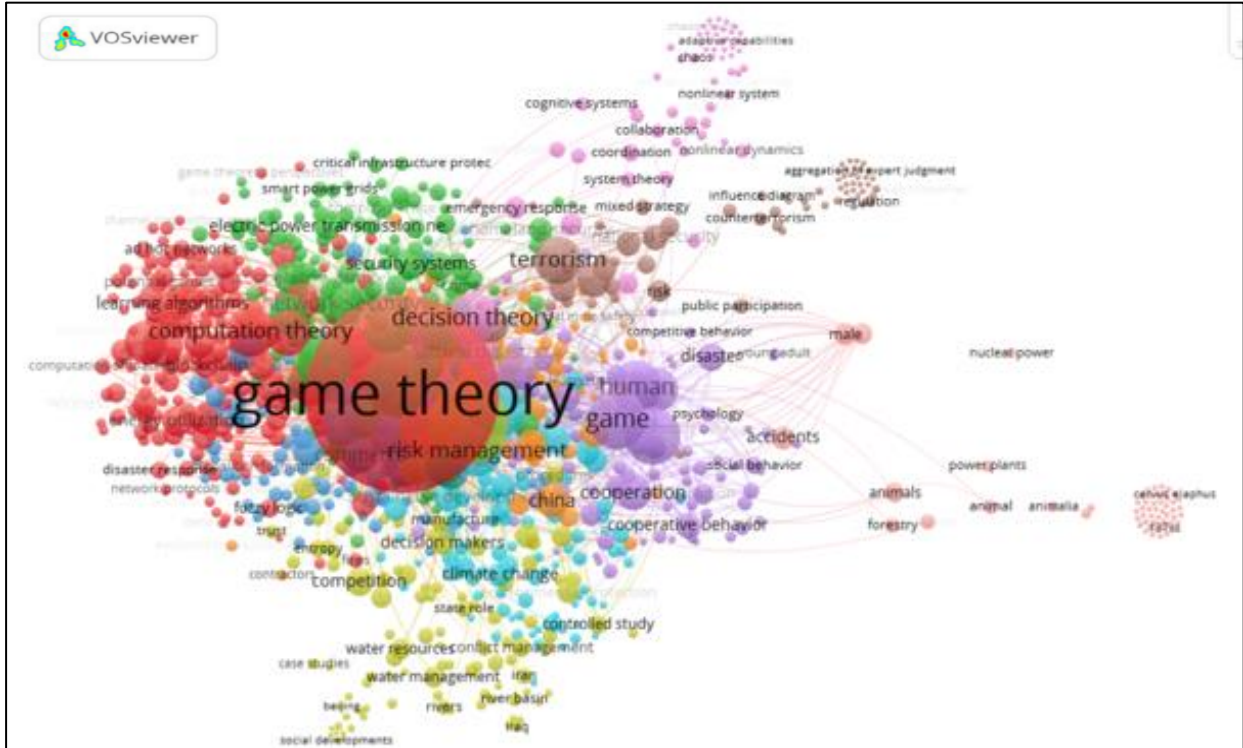

Figure 6. Keyword co-occurrence network Visualization

Looking at the relationship of keywords co-occurring over the years from the overlay visualization section, it can be seen from the contour coloring that the frequency of use increased between 2016 and 2019.

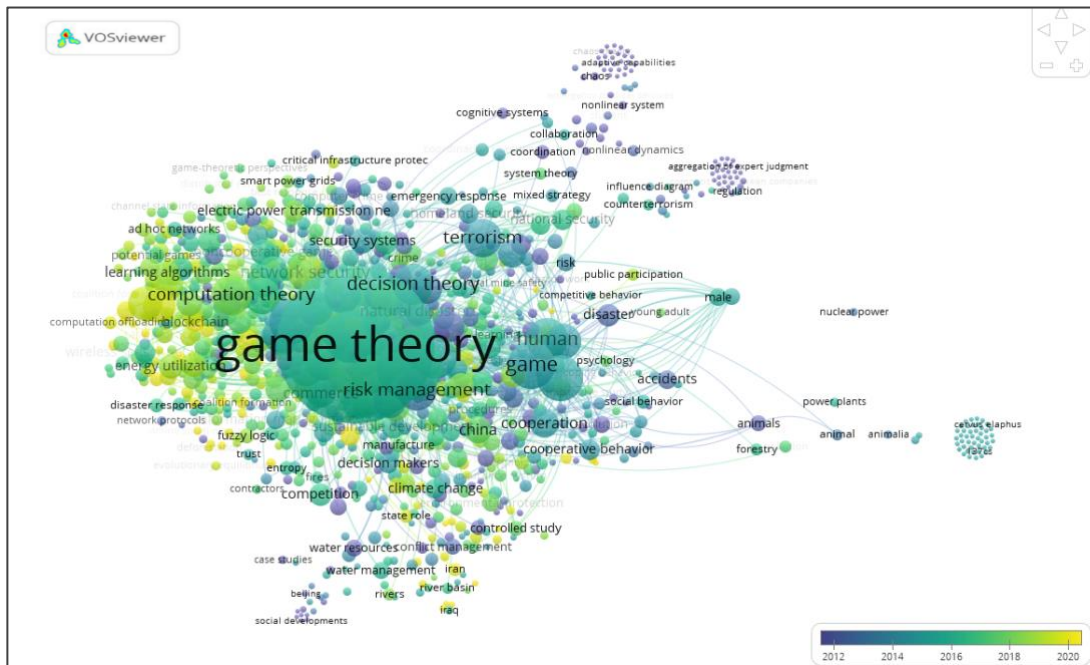

Figure 7. Game Theory and disaster Keyword co-occurrence Overlay Visualization

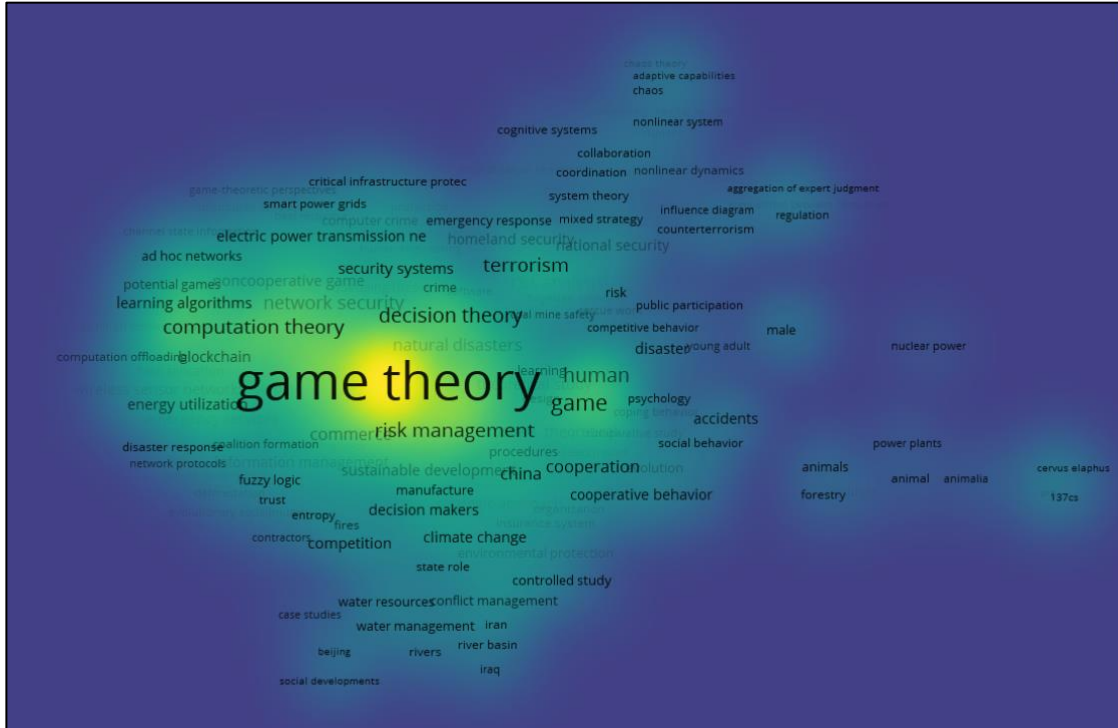

Figure 8. Keyword co-occurrence Density Visualization

Looking at the relationship of keywords co-occurring over the years from the overlay visualization section (in Figure 6 to 8), it can be seen from the contour coloring that the frequency of use increased between 2016 and 2019.

When we boundry the keywords to only game theory and disaster, we can easily see from the Figures 9 to 11 that the networks and studies decrease.

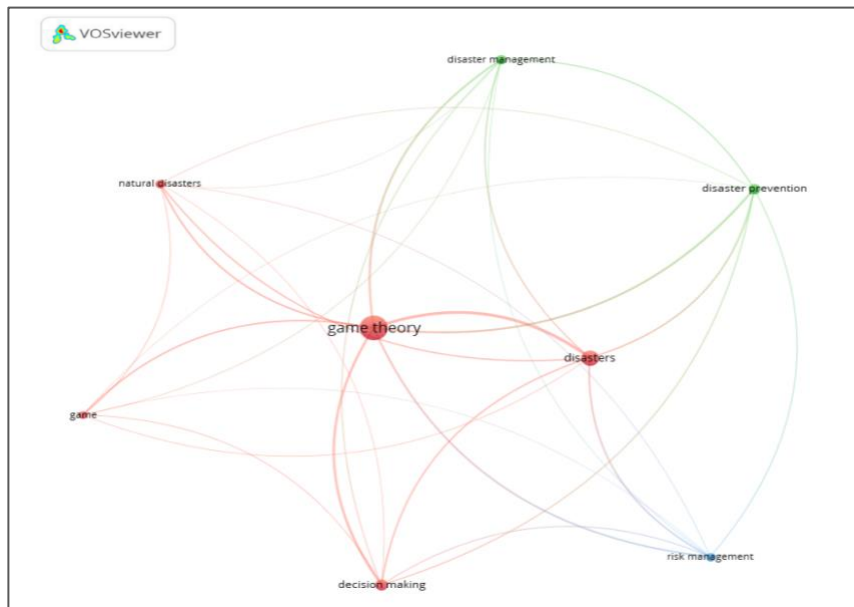

Figure 9. Game Theory and disaster Keyword co-occurrence network Visualization











of authors' citation frequency was limited to more than 50. As a result of this limitation, it was seen that 135 of all authors met the criteria. Author co-citation network. Author co-citation analysis results are shown in Figure 15.

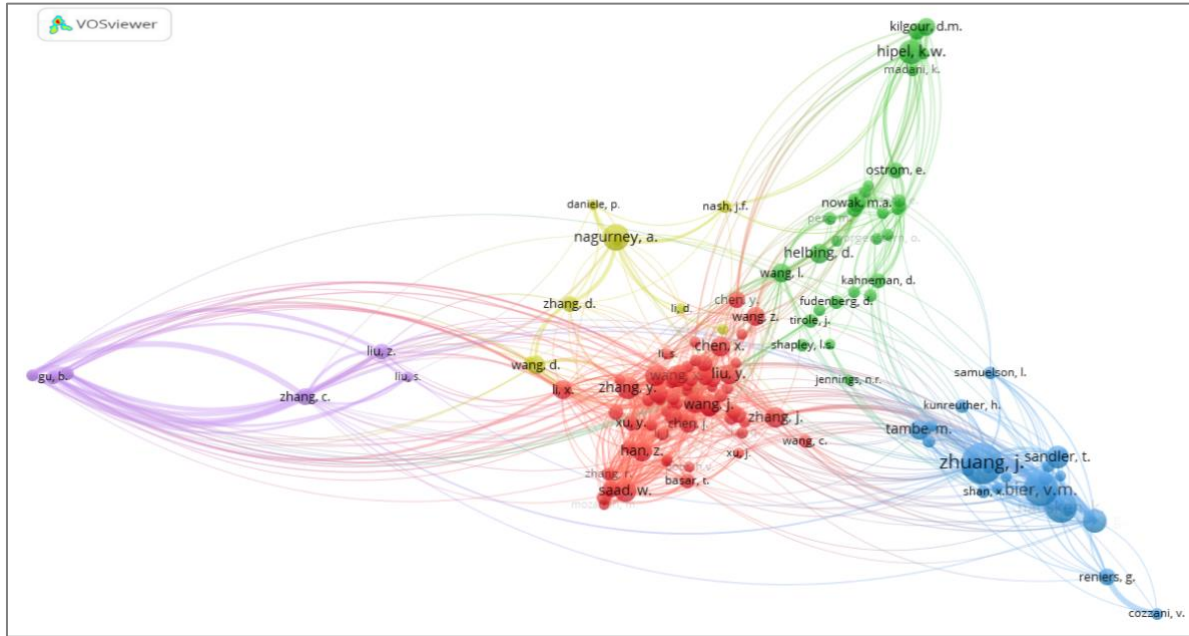

Figure. 15. Author co-citation network

As seen in the figure 15, each author is represented by nodes in the network. The thickness found in these conductnets and ties is directly related to the number of citations. Writers in the field of game theory and disaster can be grouped into six groups. Among all networks, Zhuang is the strongest networked author with 697 citations, followed by Gu, B. and Tanaka, C. They can be listed as the authors with the strongest network. While Zhuang has worked in many areas related to game theory, he has made valuable and highly cited articles on disaster.

## 5. Results

In recent years, many studies have been carried out related to humanitarian or disaster relief logistics. The existing studies may be categorized based on their focus on the subject. In this section, we review some of the contributions in the game theory approach and disaster management problems. Some of the valuable studies on game theory and disasters are shown in the Table 1. When these studies are examined, it is possible to identify the issues that are lacking and that need more work and focus.

Table 1. Literature Studies

Author-Year	Paper- Title	Subject
Hausken et al. (2009) [22]	Defending against terrorism, natural disaster, and all hazards. In: Bier VM, Azaiez MN (eds) Game theoretic risk analysis of security threats.	Natural disaster
Zhuang and Bier (2007) [23]	Balancing terrorism and natural disasters defensive strategy with endogenous attacker effort	Cost of natural disasters

Zhuang et al. (2012) [24]	Strategic interactions in disaster preparedness and relief in the face of man made and natural disasters.	Cost of natural disasters
Eid et al. (2015) [25]	Evolutionary stable strategy for postdisaster insurance: game theory approach.	Disaster mitigation
Yan and Fengyong (2008) [26]	Analysis of the mechanisms of emergency management based on game theory.	Disaster management
Chen et al. (2015) [27]	Robust supply chain strategies for recovering from unanticipated disasters.	Disaster disruption
Mulyono (2015) [28]	Mutual support in energy sector: toward energy resilience	Disaster disruption
Peng et al. (2014) [29]	The feasibility of concentrated rural settlement in a context of post-disaster reconstruction: a study of China.	Disaster recovery
Peng et al. (2014) [30]	Modeling the integrated roles of insurance and retrofit in managing natural disaster risk: a multi-stakeholder perspective.	Natural Disasters
Haphuriwat and Bier (2011) [31]	Trade-offs between target hardening and overarching protection	Disaster management
Ahmed, 2011 [32]	An overview of post-disaster permanent housing reconstruction in developing countries	Disaster
Zawawi et al., 2018 [33]	Adoption of post-disaster waste management plan into disaster management guidelines for Malaysia	Disaster management
Seaberg et al., 2017 [34]	A review of game theory applications in natural disaster management research	Natural disaster management
Madu and Kuei, 2014 [16]	Disaster relief supply chain quality management (QRSCQM)	Disaster relief
Kaklauskas et al., 2009 [14]	Knowledge model for post-disaster management	Post disaster management
Du et al, 2016 [35]	Post-disaster building repair and retrofit in a disaster-prone historical village in China: A case study in Shangli, Sichuan	Post-disaster management
Ahmadi et al, 2015 [36]	A humanitarian logistics model for disaster relief operation considering network failure and standard relief time: A case study on San Francisco district	Disaster relief operation
Celik, 2017 (37)	A cause-and-effect relationship model for location of temporary shelters in disaster operations management	Disaster operations management
Kova'cs and Spens, 2007 (38)	Humanitarian logistics in disaster relief operations	Disaster relief operations
Hosseini et al, 2016 [39]	Multi-criteria decision-making method for assessing the sustainability of post-disaster temporary housing unit technologies: A case study in Bam 2003	Post-disaster

## 6. Conclusions

Recently, Turkey, like many countries in the world, has been struggling with disasters such as earthquakes and floods. These disasters show that the issue should be dealt with in more detail, before and after, because countries still have deficiencies in disaster management. Therefore, there is a need for all kinds of useful studies that can be done on this subject. In addition, the analyzes made in this article show that studies on disaster in Turkey are quite lacking. Analysis in this article based on data from Scopus and Web of Science. Based on data from Web of Science, bibliometric approaches, including reference co-citation analysis, author co-citation analysis, and keyword association analysis were applied.

When the data obtained from the bibliographic coupling Country Analysis results are examined, the countries that conduct the most research are determined as the USA, China and the United Kingdom. When the data obtained from the Co-Authorship results are examined, the author that strongest network is determined as Zhuang. This situation reveals that the researches on game theory should be increased.

In this article, the use of game theory in disaster management is discussed. Studies in the field of game theory and disaster have been analyzed from different perspectives and statistically. In addition, some

of the most interesting articles in the field have been researched and presented in tables for more detailed analysis.

In this article, researches related to the subject are introduced and the importance of disaster management is taken into consideration. It is thought that the study will make a new contribution to the literature on the subject. In addition, it can lead to new and useful approaches in this regard by drawing attention to post-disaster studies, which are quite costly.

With this study, gaps in the field of disaster management will be identified and work can be started in these gaps. so that research studies on the subject can focus on less-represented stages in meat management.

The variety of disasters and the intensity of these disasters are different for each country. Therefore, deficiencies in the literature can be identified separately for country-specific disasters in future studies. This situation will provide for more detailed data analysis.

### **Contribution of Researchers**

All researchers have contributed equally to writing this paper.

### **Conflicts of Interest**

The authors declare no conflict of interest.

### **Referances**

- [1] M. Laituri and K. Kodrich, "On Line Disaster Response Community: People as Sensors of High Magnitude Disasters Using Internet GIS," *Sensors*, vol. 8, no. 5, pp. 3037–3055, May 2008, doi: 10.3390/s8053037.
- [2] P. Tran, R. Shaw, G. Chantry, and J. Norton, "GIS and local knowledge in disaster management: a case study of flood risk mapping in Viet Nam," *Disasters*, vol. 33, no. 1, pp. 152–169, Jan. 2009, doi: 10.1111/j.1467-7717.2008.01067.x.
- [3] Y. He, D. Zhang, and Y. Fang, "Development of a mobile post-disaster management system using free and open source technologies," *International Journal of Disaster Risk Reduction*, vol. 25, pp. 101–110, Oct. 2017, doi: 10.1016/j.ijdr.2017.08.007.
- [4] S. Ergün, P. Usta, S. Z. Alparslan Gök, and G. W. Weber, "A game theoretical approach to emergency logistics planning in natural disasters," *Annals of Operations Research*, May 2021, doi: 10.1007/s10479-021-04099-9.
- [5] R. Majumder, R. R. Warier, and D. Ghose, "Game Theory-Based Allocation of Critical Resources during Natural Disasters," in *2019 Sixth Indian Control Conference (ICC)*, Dec. 2019, pp. 514–519. doi: 10.1109/ICC47138.2019.9123232.
- [6] M. Alinaghian and A. Goli, "Location, Allocation and Routing of Temporary Health Centers in Rural Areas in Crisis, Solved by Improved Harmony Search Algorithm," *Int. J. Comput. Intell. Syst.*, vol. 10, no. 1, p. 894, 2017, doi: 10.2991/ijcis.2017.10.1.60..
- [7] A. Goli and T. Keshavarz, "Just-in-time scheduling in identical parallel machine sequence-dependent group scheduling problem," *J. Ind. Manag. Optim.*, vol.18, no. 6, pp. 3807, 2022, doi: 10.3934/jimo.2021124.
- [8] A. Goli, H. Khademi Zare, R. Tavakkoli-Moghaddam, and A. Sadeghieh, "Hybrid artificial intelligence and robust optimization for a multi-objective product portfolio problem Case study: The dairy products industry," *Comput. Ind. Eng.*, vol. 137, pp. 106090, Nov. 2019, doi: 10.1016/j.cie.2019.106090.
- [9] A. Goli, H. Khademi-Zare, R. Tavakkoli-Moghaddam, A. Sadeghieh, M. Sasanian, and R. Malekalipour Kordestanizadeh, "An integrated approach based on artificial intelligence and novel meta-heuristic algorithms to predict demand for dairy products: a case study," *Netw. Comput. Neural Syst.*, vol. 32, no. 1, pp. 1–35, Jan. 2021, doi: 10.1080/0954898X.2020.1849841.
- [10] A. Goli and B. Malmir, "A Covering Tour Approach for Disaster Relief Locating and Routing with Fuzzy Demand," *Int. J. Intell. Transp. Syst. Res.*, vol. 18, no. 1, pp. 140–152, Jan. 2020, doi: 10.1007/s13177-019-00185-2.
- [11] A. Goli and H. Mohammadi, "Developing a sustainable operational management system using hybrid Shapley value and Multimoora method: case study petrochemical supply chain," *Environ. Dev. Sustain.*, vol. 24, no. 9, pp. 10540–10569, Sep. 2022, doi: 10.1007/s10668-021-01844-9.
- [12] E. B. Tirkolae, A. Goli, P. Ghasemi, and F. Goodarzian, "Designing a sustainable closed-loop supply chain network of face masks during the COVID-19 pandemic: Pareto-based algorithms," *J. Clean. Prod.*, vol. 333, Jan. 2022, doi: 10.1016/j.jclepro.2021.130056.

- [13] S. , E. O. , K. P. and S. J. L. Duran, "Humanitarian Logistics: Advanced Purchasing and Pre-Positioning of Relief Items," in *Handbook of Global Logistics –Transportation in International Supply Chains*, J. H. Bookbinder, Ed. New York: Springer, 2013, pp. 447–461.
- [14] A. Kaklauskas, D. Amaratunga, and R. Haigh, "KNOWLEDGE MODEL FOR POST-DISASTER MANAGEMENT," *International Journal of Strategic Property Management*, vol. 13, no. 2, pp. 117–128, Jun. 2009, doi: 10.3846/1648-715X.2009.13.117-128.
- [15] B. M. Roger, *Game theory: Analysis of conflict*. USA.: The President and Fellows of Harvard College, 1991.
- [16] C. N. Madu and C.-H. Kuei, "Disaster relief supply chain quality management (DRSCQM)," *International Journal of Quality & Reliability Management*, vol. 31, no. 9, pp. 1052–1067, Sep. 2014, doi: 10.1108/IJQRM-08-2013-0136.
- [17] A. S. Barough, M. V. Shoubi, and M. J. E. Skardi, "Application of Game Theory Approach in Solving the Construction Project Conflicts," *Procedia - Social and Behavioral Sciences*, vol. 58, pp. 1586–1593, Oct. 2012, doi: 10.1016/j.sbspro.2012.09.1145.
- [18] A. Nagurney, "Game Theory and the COVID-19 Pandemic," in *Tutorials in Operations Research: Emerging Optimization Methods and Modeling Techniques with Applications*, INFORMS, 2021, pp. 83–130. doi: 10.1287/educ.2021.0226.
- [19] E. S. , G. S. Z. A. , Usta P., " Game Theory Applications in Civil Engineering, Construction, and Building Industry," Nov. 2019.
- [20] Q. Commine and J. Aboiron, "Application of Game Theory in Middle-Management: A Military Historical Study of the Role of the Middle-Manager as a Correlated Equilibrium Factor in the Decision-Making Process," *International Journal of Applied Research in Business and Management*, vol. 2, no. 1, pp. 51–64, Jun. 2021, doi: 10.51137/ijarbm.2021.2.1.5.
- [21] J. Liu, Y. Chen, and Y. Chen, "Emergency and disaster management-crowd evacuation research," *Journal of Industrial Information Integration*, vol. 21, p. 100191, Mar. 2021, doi: 10.1016/j.jii.2020.100191.
- [22] B. V. Z. J. Hausken K, "Defending against terrorism, natural disaster, and all hazards. In: Bier VM, Azaiez MN (eds) *Game theoretic risk analysis of security threats*," in *International series in operations research and management science*, vol. 128, Boston, MA: Springer, 2009.
- [23] J. Zhuang and V. M. Bier, "Balancing Terrorism and Natural Disasters—Defensive Strategy with Endogenous Attacker Effort," *Operations Research*, vol. 55, no. 5, pp. 976–991, Oct. 2007, doi: 10.1287/opre.1070.0434.
- [24] C. J. G. P. H. F. S. X. Zhuang J, "Strategic interactions in disaster preparedness and relief in the face of man-made and natural disasters," 2012.
- [25] E. I. C. K. Eid MS, "Evolutionary stable strategy for postdisaster insurance: game theory approach," *J Manag Eng* , vol. 31, no. 6, 2015.
- [26] F. Z. Yan W, "nalysis of the mechanisms of emergency management based on game theory," in *roceedings of 2008 international conference on construction and real estate management*, vol. 1–2, X. K. S. Q. Wang YW, Ed. 2008, pp. 1565–1568.
- [27] L.-M. Chen, Y. E. Liu, and S.-J. S. Yang, "Robust supply chain strategies for recovering from unanticipated disasters," *Transportation Research Part E: Logistics and Transportation Review*, vol. 77, pp. 198–214, May 2015, doi: 10.1016/j.tre.2015.02.015.
- [28] N. B. Mulyono, "Mutual Support in Energy Sector: Toward Energy Resilience," *Procedia Computer Science*, vol. 60, pp. 1041–1050, 2015, doi: 10.1016/j.procs.2015.08.149.
- [29] Y. Peng, L. Shen, X. Zhang, and J. J. Ochoa, "The feasibility of concentrated rural settlement in a context of post-disaster reconstruction: a study of China," *Disasters*, vol. 38, no. 1, pp. 108–124, Jan. 2014, doi: 10.1111/disa.12032.
- [30] J. Peng et al., "Modeling the integrated roles of insurance and retrofit in managing natural disaster risk: a multi-stakeholder perspective," *Natural Hazards*, vol. 74, no. 2, pp. 1043–1068, Nov. 2014, doi: 10.1007/s11069-014-1231-3.
- [31] N. Haphuriwat and V. M. Bier, "Trade-offs between target hardening and overarching protection," *European Journal of Operational Research*, vol. 213, no. 1, pp. 320–328, Aug. 2011, doi: 10.1016/j.ejor.2011.03.035.
- [32] I. Ahmed, "An overview of post-disaster permanent housing reconstruction in developing countries," *International Journal of Disaster Resilience in the Built Environment*, vol. 2, no. 2, pp. 148–164, Jul. 2011, doi: 10.1108/17595901111149141.
- [33] E. M. A. Zawawi, N. S. Yusof, and Z. Ismail, "Adoption of post-disaster waste management plan into disaster management guidelines for Malaysia," *Journal of Material Cycles and Waste Management*, vol. 20, no. 1, pp. 223–236, Jan. 2018, doi: 10.1007/s10163-016-0569-x.

- [34] D. Seaberg, L. Devine, and J. Zhuang, "A review of game theory applications in natural disaster management research," *Natural Hazards*, vol. 89, no. 3, pp. 1461–1483, Dec. 2017, doi: 10.1007/s11069-017-3033-x.
- [35] F. Du, K. Okazaki, C. Ochiai, and H. Kobayashi, "Post-disaster building repair and retrofit in a disaster-prone historical village in China: A case study in Shangli, Sichuan," *International Journal of Disaster Risk Reduction*, vol. 16, pp. 142–157, Jun. 2016, doi: 10.1016/j.ijdr.2016.02.007.
- [36] M. Ahmadi, A. Seifi, and B. Tootooni, "A humanitarian logistics model for disaster relief operation considering network failure and standard relief time: A case study on San Francisco district," *Transportation Research Part E: Logistics and Transportation Review*, vol. 75, pp. 145–163, Mar. 2015, doi: 10.1016/j.tre.2015.01.008.
- [37] E. Celik, "A cause and effect relationship model for location of temporary shelters in disaster operations management," *International Journal of Disaster Risk Reduction*, vol. 22, pp. 257–268, Jun. 2017, doi: 10.1016/j.ijdr.2017.02.020.
- [38] G. Kovács and K. M. Spens, "Humanitarian logistics in disaster relief operations," *International Journal of Physical Distribution & Logistics Management*, vol. 37, no. 2, pp. 99–114, Mar. 2007, doi: 10.1108/09600030710734820.
- [39] S. M. Amin Hosseini, A. de la Fuente, and O. Pons, "Multi-criteria decision-making method for assessing the sustainability of post-disaster temporary housing units technologies: A case study in Bam, 2003," *Sustainable Cities and Society*, vol. 20, pp. 38–51, Jan. 2016, doi: 10.1016/j.scs.2015.09.012.



# Frugal innovation concept as an indispensable solution for normal and crisis situations Morocco facing COVID-19

Bilal KARROUMİ<sup>1\*</sup>, Abdelfettah SEDQUI<sup>2</sup>

<sup>1</sup>Innovative technologies laboratory; [0000-0002-1746-1300](https://doi:10.55185/researcher.1210872)

<sup>2</sup>Innovative technologies laboratory; [0000-0002-7446-0400](https://doi:10.55185/researcher.1210872)

\*Corresponding Author: [karroumi.bilal@gmail.com](mailto:karroumi.bilal@gmail.com)

Received: 17 September 2022; Accepted: 18 December 2022

**Reference/Atf:** B. Karroumi, A. Sedqui, "Frugal innovation concept as an indispensable solution for normal and crisis situations Morocco facing COVID-19", Researcher, vol. 02, no. 02, pp. 96-105, Dec. 2022, doi:10.55185/researcher.1210872

## Abstract



The world occasionally experiences serious natural or man-made problems that have an impact on several industries. These circumstances affect both established and emerging nations, and they call for swift, nimble, and adaptable responses from concerned decision-makers. COVID-19 is an illustration. Due to its traits, frugal innovation is a good way to respond to regular or urgent problems that call for swift adaptation to the current environment and a lack of resources. The purpose of this effort is to: Clarify the concept of frugal innovation and its features; investigate how well the frugal innovation strategy adapts to both normal and emergency scenarios; expose how Morocco is responding to the COVID-19 Pandemic using this technique, and propose frugal innovation as a crucial component for success in the Moroccan context. The study's findings proved that frugal innovation may be a beneficial solution in a variety of real-world situations for all nations, and they supported Morocco's use of this approach as a development tool in normal situations and a crisis-relief tool.

**Keywords:** frugal innovation, crises, resource constraints, covid-19, resilience.

## 1. Introduction

Economic, social, and health crises threaten the stability of the global community and its pursuit of unceasing progress. Because these crises are characterized by shifting priorities and increased consumer demands, decision-makers must be able to respond quickly to potential threats and ensure that needs are met to the highest standard. Since they have a limited amount of time to develop solutions and few resources at their disposal, they must come up with quick and adaptable solutions to make the most efficient use of what they do have.

The sudden emergence of economic, social, and health crises necessitates unprecedented responses. Because the crisis affects all nations in the world, the various scenarios are built on the exploitation of what is already in place. This exploitation is furthered by adopting a frugal innovation strategy based on the idea of getting more done with less.

Researchers and inventors from developing nations are familiar with and use the concept of frugal innovation (India, Kenya...). It aims to boost design and development processes' efficiency while raising the standard of the services provided and reducing costs, producing more social and economic benefits by using less money and limited natural resources, and leading to the creation of sustainable concepts that can adapt to different life circumstances.

In addition to worldwide crises, such as COVID-19, other crises that are often connected to the country's economic or social issues also afflict specific nations. While the crises that strike individual nations are marked by solidarity and assistance from nearby countries as a consequence of contracts and agreements signed between these countries, the managing of these crises varies in the source of support and the means that may be utilized to satisfy the urgent demands stated, while the modular crises need exploitation of existing resources internally and to design local, economic solutions particular to the country in question. By developing crisis management strategies based on domestic resources, the frugal innovation idea increases independence, which will lessen the effects of reversing course to other nations after the crisis.

Morocco is held up as an example for its adaptability, leadership—particularly its coherence in decision-making—and the participation of the populace through the COVID-19 Special Fund and the media to maintain public trust. Whether they are focused on society, the economy, or the environment. It draws attention to the nation's inventiveness and utilization of thrifty methods. Additionally, it places a crisis regarding the UN's goals for sustainable development and the new economic model. [1]

The purpose of this research is to: Simplify the concept of frugal innovation and its traits; investigate the adaptability of the approach in both normal and emergencies with a focus on its impact on supply chain resilience; expose Morocco's abuse of this approach in its response to the COVID-19 Pandemic, and introduce frugal innovation as a factor in the success for the context of Morocco.

The remainder of this article is structured as follows. Summarize the idea of frugal innovation and its attributes in Section 2. The flexibility of the frugal innovation strategy in both regular and emergency scenarios is then described in section 3. In Section 4, we reveal how Morocco used this strategy to combat the COVID-19 Pandemic. Conclusions supporting frugal innovation as a successful element in the Moroccan setting are presented in Section 5.

## **2. Frugal innovation: Definition and characteristics**

In recent years, there have been several definitions of frugal innovation. The various definitions exhibit evolution even if they share certain fundamental traits. Therefore, existing definitions in the literature have been examined throughout time to offer a thorough knowledge of the word. The phrase "frugal engineering," which was first used in 2006 by Carlos Ghosn, President, and CEO of the Renault-Nissan Alliance, and which has been able to develop quickly, affordably, and with very little resources, is where the idea of frugal innovation first emerged (Soni and Krishnan, 2013). The Economist published one of the first definitions in 2010: "Frugal items must be reliable and simple to use (...). Rethinking all business models and production processes is also a part of frugal innovation, in addition to product design [2][3].

Similar to how Rajnish Tiwari and Cornelius Herstatt defined the term "frugal innovation," they believed that it applied to new goods and services that "seek to minimize the use of material and financial resources in the entire value chain (development, manufacturing, distribution, consumption, and disposal) to reduce the cost of ownership while meeting or even exceeding certain predefined criteria of acceptable quality standards" [4].

According to Bhatti, Y.A. (February 1, 2012), frugal innovation can refer to both procedures and results, hence its definitions might overlap. It can relate to cost-effective innovation methods including reverse diffusion (Govindarajan and Ramamurti, 2011) [5], reverse engineering, DIY (Levi-Strauss, 1967), creative improvisation (jugaad) (Gulati, 2010), design methodologies, and the use of tools like open-source approaches. Jugaad is described as an improvisational innovation method driven by resource depletion and focused on the urgent demands of customers rather than their lifestyle (BusinessWeek, 2009) [6].

Affordably priced, high-quality solutions that are targeted at underserved clients in the low and medium-market sectors are known as frugal innovations (Zeschky et al., 2014; Ernst et al. Young, 2011; Soni, 2013) [7]. They are created efficiently and responsibly, reducing their negative effects on the environment. maximizing societal value via the efficient use of resources, materials, and capital across the whole company (Bhatti, 2012; Tiwari and Herstatt, 2014; Radjou and Prabhu, 2015) [8].

## **3. Frugal innovation during Normal and Crisis situations**

Frugal innovation is a sustainable development technique that tries to create flexible and economical adaptive solutions in situations with limited resources. From an economic standpoint, Frugal innovation may be quite profitable. Using fewer resources and energy, may support environmental goals and strives to accomplish more with less. This theory applies to a variety of life circumstances, including both critical and normal circumstances [8][9]. The following examples demonstrate how this strategy may work in both scenarios.



### **3.1 Frugal innovation: Normal situation**

The purpose of frugal innovation is to provide simple, cost-effective solutions for consumer groups with high price sensitivity. This study analyzes the similarities and contrasts between two key strategies; corporate innovation and grassroots innovation and offers some early suggestions for how the two streams could complement one another. The next paragraphs provide descriptions of both strategies.

#### **3.1.1 Corporate frugal innovation**

Changing the working methods and mindsets of R&D teams can be a complicated process, especially when new ways of thinking present risks in their consequences for the teams involved. In this context, the development of frugal solutions makes it a challenge to design high-end products with reduced costs while maintaining the quality of the company or entity brand.

Developed countries venture with frugal innovations especially when it comes to meeting the specific needs of well-selected customer segments. After selecting the segments based on the cost sensitivity of the customers and after a detailed analysis of the expressed needs, decisions are made to meet the need with satisfactory quality and at affordable prices. Sometimes, additional relevant features are added for targeted customers although these features increase the price of products or services rendered. The conclusion of this process is a product of good quality and cheaper than the one already provided in those developed countries [10].

#### **3.1.2 Grassroot frugal innovation**

The frugal innovation strategy arose in underdeveloped nations with huge grassroots populations. Going back to the beginning of frugal innovation, we see that it prioritizes meeting the demands of this market segment.

Research and analysis performed on developing economies have shown that the reuse of materials and objects that are easy to exploit represents the core of frugal innovation. In addition, these innovations are characterized by the ingenious way in which they find solutions to replace the lack of tools and means stated in different situations. The remarkable difference between these economies and developed economies is the level of skills and tools used for the same practices.

The comparison demonstrates how several frugal streams might benefit in some manner from one another. Businesses may learn how to fundamentally rethink innovation by studying the resource-constrained development methods used by grassroots frugal innovators. Both approaches' methods and resources can be useful [10].

Category	Corporate Frugal	Grassroot Frugal
<b>Driver</b>	Companies	Individual inventors
<b>Impulse</b>	Market opportunity	Clever idea
<b>Sustainability</b>		
Economic	1-High profitability Targeted	1-Low economic profitability accepted
Environmental	2-Secondary motivation	2-Secondary motivation
Social	3-Secondary motivation	3-Secondary motivation
<b>Quality</b>	In line with brand	Good enough for target customers
<b>Production scale</b>	Mass- manufacturing	Single items and small series
<b>Development process</b>	1-Complex, Resource -intensive 2-Structured 3-Elaboration prototypes	1-Simple, resource-restricted 2-Improvised 3-Early, fast, frequent prototyping
<b>Success factors</b>	Corporate R&D teams	Input from other designers
<b>Challenges</b>	Cannibalization of existing offering	Upscaling

Figure 1: Comparison between Corporate and Grassroot frugal innovation

### 3.1.3 Frugal innovation: Environment aspects

As an indispensable factor, the environment takes an important space among new projects, technologies, and development projects. The frugal innovation approach as a general concept is valid for different fields including the environmental aspect, the proposition of frugal solutions to reduce pollution, optimize natural resources consumption, manage waste, and produce renewable energy become a priority and not an option. In this regard, Erfan Babae Tirkolae and Gerhard-Wilhelm Weber performed several studies and proposed different environmental solutions such as using Pareto-based methods, multi-objective optimization performed for the reliable pollution-routing issue with cross-dock selection [11], using Pareto-based algorithms in a novel model for the sustainable garbage collection arc routing problem [12] and For urban solid waste management, a hybrid augmented ant colony optimization for the multi-trip capacitated arc routing issue with ambiguous needs [13]. The proposed solutions example of cross-docking practice contributes to improving the efficiency of environmental aspects.

From the perspective of the frugality concept and in other fields than the environment, Erfan Babae Tirkolae and Gerhard-Wilhelm Weber performed case studies in supply chain management such as a strong just-in-time flow shop scheduling problem with subcontractor outsourcing options [14]. Other efforts were done during the crisis such as the COVID-19 pandemic, an example of a problem of managing medical waste during the COVID-19 epidemic sustainably using fuzzy multi-trip location-routing, the last work was initiated in 2020 [15].

Successful studies present a great opportunity and show the ability to achieve a good result through the application of frugal innovation concepts. Some authors propose frugal solutions under other concept

names; economic, optimized, reliable, and flexible solutions with the same finality. And from this vision, a lot of occasions are available to conceptualize our proposed concept and make it a helpful concept to improve several situations.

### 3.2 Frugal innovation: Crisis situations

#### 3.2.1 Frugal innovations during crisis situations

Finding quick, adaptable, and reasonably priced solutions in contexts with constrained resources is the goal of the frugal innovation sustainable development method. The strategy is more well-known in emerging and underdeveloped nations as a result. This strategy is regarded as a cornerstone of development in developing nations, while it also serves as a life-saving component in impoverished and affected nations. The success of thrifty innovation in underdeveloped and suffering nations makes it a success factor for resolving many problems.

In crises, people show their ingenuity in finding solutions that fit their needs. Necessity is the mother of invention is a very favorable principle in these situations. Regulatory norms can become additional constraints to respond to urgent needs, for this reason, it is recommended to renounce these norms to react quickly to the expressed demands with affordable prices. The need for frugal solutions in developing countries to increase the quality of healthcare services has long been recognized, and the same is true for developed countries that are adopting this humble approach to innovation. The impact of the global crisis on the way innovation is done needs to be verified for this field of health care. This context encourages the adoption of reverse innovation concepts to facilitate the work of researchers in developing countries in dealing with the improved global knowledge flow [16].

The most essential lesson for mankind here may be to learn from everyone and for everyone when the COVID-19 epidemic is over. The pandemic may be the greatest equalizer of our time and educate us to understand the weakness of all of our healthcare systems. At least this one good thing may come out of it.

In summary, the table below demonstrates how frugal innovation may be used in every situation; An illustration of entrepreneurial action in a crisis [17]:

Crisis phase	Frugality
Pre-Crisis	<ul style="list-style-type: none"> <li>Adopt a frugal culture incentivize resourceful behaviors and focus on the long-term survival of the venture</li> </ul>
In-Crisis	<ul style="list-style-type: none"> <li>Focus on resource conservation, identify and Prioritize resources the contribute directly to the product/service revenues</li> </ul>
Response	<ul style="list-style-type: none"> <li>Sell-off and divest resources with no contribution to the long-term vision</li> </ul>
Post-Crisis	<ul style="list-style-type: none"> <li>Adopt a frugal culture for resource acquisition. Focus on quality goods and service instead of the most cost-effective</li> </ul>
Recovery	<ul style="list-style-type: none"> <li>Time acquisitions to reinforce your negotiation power.</li> </ul>

Figure 2: Framework for Frugal Innovation in different crisis phases

#### 3.2.2 Resilient supply chain during the crisis

##### 3.2.2.1 Resilience Definition

The resilient as interest concept will be explained first to describe the resilience of the supply chain and how it may be developed. Resilience has two straightforward definitions, according to the Oxford Dictionary: the capacity to quickly recover from a challenging circumstance and the ability of an object

to return to its former shape. Resilience is the capacity of a system to return to its initial condition or to transition to a new, more desired state after being disrupted, according to the definition provided by M. Christopher and H. Peck [18] [19]. Resilience will be used in this sense to refer to the supply chain with a frugality mindset. [20].

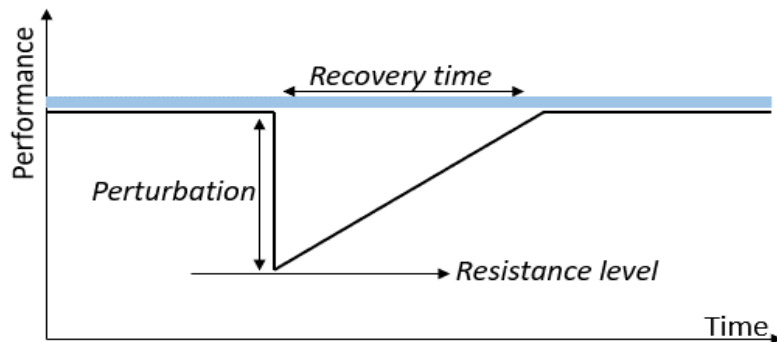

Figure 3: Resistance and Recovery ability of resilience supply chain

### 3.2.2.2 Resilient supply chain building

A supply chain's resilience is determined by a set of requirements that have been described differently by various writers. Four guiding principles were established by M. Christopher and H. Peck [18] for creating a resilient supply chain: Supply Chain Collaboration, which includes “collaborative planning”, “supply chain intelligence”, “Agility”, and “Supply Chain Risk Management Culture” are all components of supply chain reengineering. To accomplish the required supply chain resilience, Tang [21] cites the following nine strategies: “deferral, strategic stock, flexible supply base, make-and-buy trade-off, economic supply incentives, flexible transportation, revenue management, dynamic assortment planning, and quiet product rollover”. From other voices, Iakovou, Vlachos, and Xanthopoulos [22] proposed “flexible sourcing, demand-based management, strategic safety stock, comprehensive SC visibility, and process and knowledge backup” as the guiding principles for the ideal architecture of resilient supply chains. Resilience may be built on two distinct pillars, according to Y. Sheffi and J. Rice [23]: building redundancy or constructing flexibility.

To develop a resilient supply chain, Wicher, P., & Lenort, R. [20] have divided the previously described components into three categories: “supply chain design”, “process design”, and “relationship design”.

The supply chain design is built on many sources of sourcing, the agility principle, and matching design and needs. To minimize potential interruptions, the process design is concerned with the redundancy of inventories, spare capacity to offer efficiency and flexibility when necessary, and velocity to enable a swift flow of material between partners. Ultimately, the relationship design emphasizes partner cooperation, data and information exchange, and trust networks.

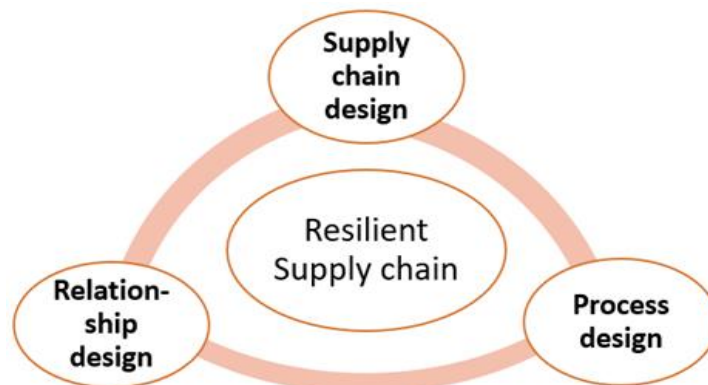

Figure 4: Categories of Resilient Supply Chain

### 3.2.2.3 Resilient supply chain during the crisis

Due to a lack of resources and restrictions on the physical movement of goods in many industries, the crisis has brought to light the supply chain's limitations and created new obstacles that cause delays in lead time needs. To meet these issues, it is essential to build a resilient supply chain, which is based not only on creative solutions but also on economical ones that will enable foresight of expressed demands, resistance to resource shortages, and flexibility to the changes imposed by the crisis. This flexibility is demonstrated by the factories' ability to substantially alter their operations and build additional plants to fulfill demand.

By using frugal alternative resources and locally developed solutions, the supply chain's resilience strengthens the fight against the super-cycle of raw materials during the crisis. These traits provide other nations independence and, in the end, reduce the consequences of dependency after the crisis.

## 4. Morocco facing COVID-19 through Frugal innovation

To achieve significant economic and social performance with a sensible consumption of available resources, Morocco's status as a developing nation is viewed as a favorable environment for the implementation of frugal innovation concepts.

Morocco had an interesting ability to respond to the requirements of several levels; social, economic, and health during the COVID-19 epidemic. According to the adage "necessity is the mother of invention," economical inventions have been put forth and put to use in Morocco, a country recognized for its scarce resources and the extremely short reaction times needed to deal with the COVID-19 epidemic.

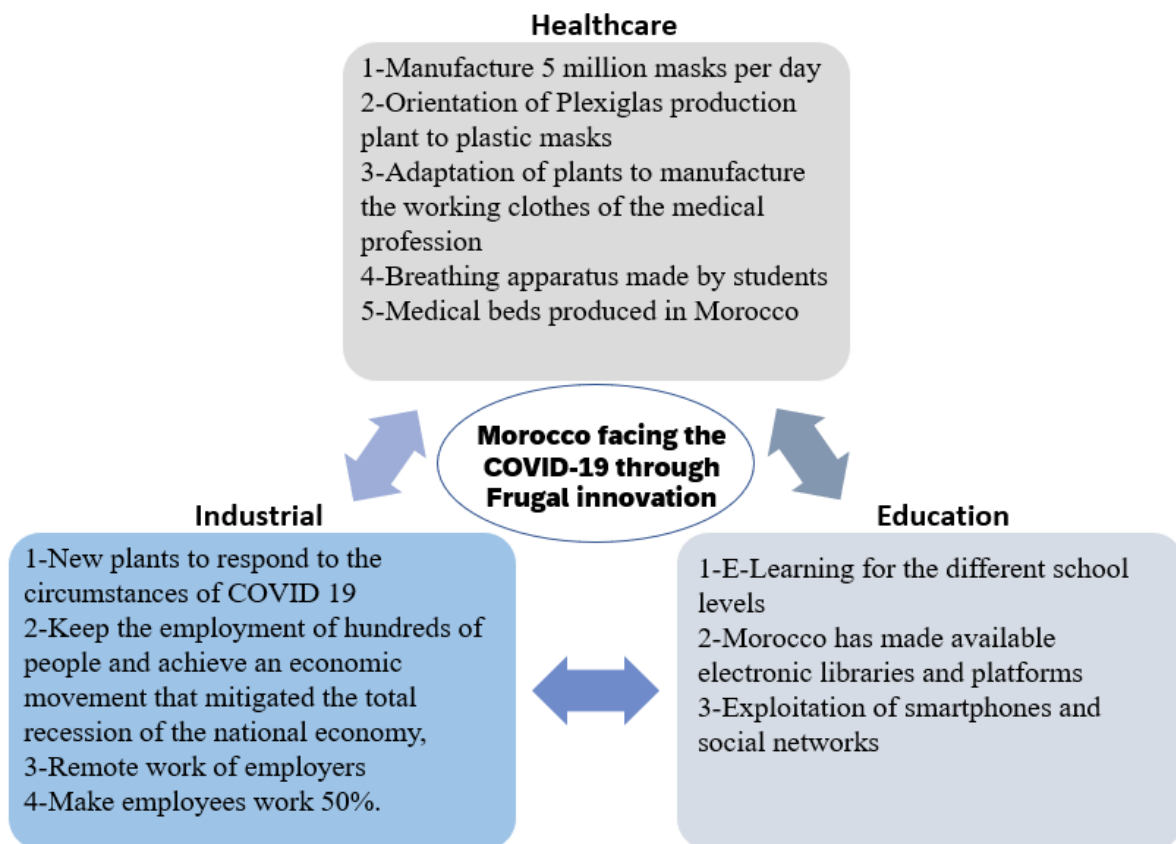

Figure 5: Morocco facing COVID-19 through Frugal innovation

*Healthcare:* Frugal innovation in healthcare refers to the capacity to offer safe treatment in the most cost-effective manner feasible given the conditions and limits. The Ministry of Industry, Green Economy, and Digital Technology of Morocco has partnered with textile mills to produce subsidized masks for widespread distribution via a variety of channels. To satisfy the population's demands for protection, the factory was guaranteed to be able to create 5 million masks per day commencing in April 2020. To stop the spread of infection, Plexiglas-cutting experts reorganized their factories to make plastic masks. Additionally, the production facilities have been modified to produce the medical workers' uniforms in record time [1]. A novel breathing apparatus was created by MIT (Multi Information Technology) students, who also made the world's usage and assembly instructions more understandable. To meet the need for artificial respirators and medical equipment, many inventive people were able to adapt the invention, which had become affordable in Africa and other parts of the world. Additionally, Morocco is upgrading its hospital equipment by using Moroccan-made beds rather than paying four times as much to buy them from elsewhere.

*Education:* Morocco has immediately responded to the COVID-19 situation in the educational sphere by depending on E-Learning for the various school levels, including exams and debates of theses. By utilizing cell phones, social networks, and television channels, Morocco has made sure that there are electronic platforms available to make information access easier. This helps to achieve the Moroccan orientation [1].

*Industrial:* The development of new plants with activities in response to COVID-19's circumstances and the radical alteration of some plants' activities to satisfy the expressed needs enable these plants to maintain their viability throughout the crisis, maintain the employment of hundreds of people, and accomplish economic movement that lessened the overall economic downturn in the country. Companies have also suggested other adaptable and quick-thinking solutions during this crisis in Morocco, such as remote work employers, several factories have chosen to require workers to work 50% of the time rather than permanently removing them from their jobs, and in this way, the businesses have been able to maintain the employment of hundreds of people while minimizing the effects of this global crisis [1].

#### 4.1 Results of Frugal innovation exploited by Morocco facing the COVID-19

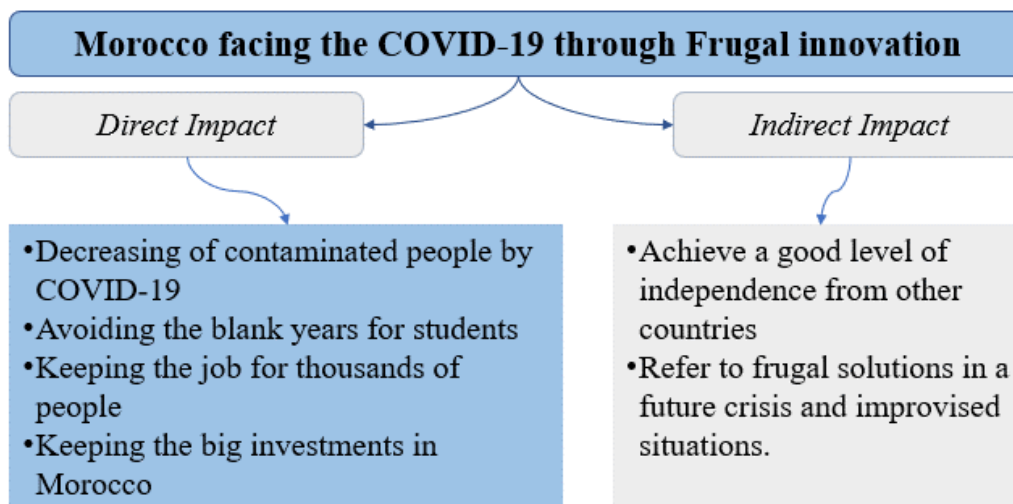

Figure 6: Results of Frugal innovation exploited by Morocco facing the COVID-19

As result, a positive impact was reached by frugal solutions for several sectors; Decreasing interest in the percentage of contaminated by COVID-19 as well as people hospitalized, avoiding the blank years for students for different levels, keeping the job for thousands of people by adopting home-office and half-time working approach, in addition to keeping the big investments during a difficult situation. The direct listed results guide to achieving an important indirect goal such as independence from other countries during and after the crisis and refer to frugal solutions in a future crisis or improvised

situations. The success of Morocco during the COVID-19 pandemic by using simple solutions and exploiting existing resources was proven by reasonable reactivity vis à vis the appearance of different coronavirus waves, and it has managed to pass them without health crises or deterioration of the country's economy.

## **5. Conclusion and Future Research**

The global economy is under intense pressure from a variety of factors, including consumer expectations, competitiveness, and resource limitations in everyday situations, as well as rapid responses and nimble, adaptable solutions in critical situations. The frugal innovation notion is important at this point as an approachable option as this demand is rising in emerging nations. At the level of small and large firms, Morocco has demonstrated excellent flexibility in the frugal innovation method.

**Small business:** The term "bricolage" is frequently used to describe the resourceful ways that poor, ordinary people manage to come up with creative solutions to expensive difficulties, including several traditional crafts.

**Major business:** Carlos Ghosn, the head of the Renault-Nissan company, integrated the idea by producing an economical automobile in an economical plant; the initiative was a huge success [24].

To retain public trust in society, the economy, and the environment, Morocco is recognized as an example for its adaptability, leadership, and particularly its coherence in decision-making and the engagement of the populace through the media and the COVID-19 Special Fund. It highlighted the ingenuity and resourcefulness that the nation has displayed.

We conclude that frugal innovation plays a role in the success and development of nations; the strategy will assist Morocco in framing and giving significance to "system D" jobs and craft activities, particularly given that a sizable portion of the Moroccan people depends on these activities; on the other hand, the success of big projects like Renault-Nissan will inspire Moroccan and international enterprises to embrace the idea of frugal innovation and increase foreign investment to settle in Morocco. Morocco may also take use of the benefits offered by a robust supply chain built on economical solutions for various industries.

Morocco's accomplishment against COVID-19 through the deployment of frugal solutions will show this idea as a relief element in crisis scenarios, particularly when the outcomes are mainly favorable when compared to the techniques utilized in an emerging market like Morocco. This success has been continued by managing the coronavirus waves without health crises or deterioration of the country's economy.

Future research will highlight this approach as an important axis to be well studied and provide it as a guiding and close-to-use solution for crisis prevention and as a relief factor during difficult situations which may be a complicated problem, a difficult challenge, or a crisis in any field. On the other hand, the concept of frugal innovation can be developed within maker space and Fablabs in Morocco as a trigger for interesting ideas of improvements and inventions. This will change the mindset of people towards the acceptance of changes and ensure a dynamic and continuity of development in all sectors.

### **Contribution of Researchers**

All researchers have contributed equally to writing this paper.

### **Conflicts of Interest**

The authors declare no conflict of interest.



## References

- [1] Bouhia, Hynd. "Le Maroc face au Covid-19: Agilité, Cohésion et Innovation/Morocco and Covid-19: Agility, Cohesion, Innovation.", 2020.
- [2] The Economist, <https://www.economist.com/special-report/2010/04/17/first-break-all-the-rules>. 2010.
- [3] Soni, Pavan, and Rishikesh T. Krishnan. "Frugal innovation: aligning theory, practice, and public policy." *Journal of Indian Business Research*, 2014.
- [4] Tiwari, Rajnish, and Cornelius Herstatt. "Frugal innovation: A global networks' perspective." *Unternehmung: Swiss Journal of Business Research and Practice* 66.3, 2012.
- [5] Govindarajan, Vijay, and Ravi Ramamurti. "Reverse innovation, emerging markets, and global strategy." *Global strategy journal* 1.3-4: 191-205, 2011
- [6] Bhatti, Yasser Ahmad. "What is frugal, what is innovation? Towards a theory of frugal innovation." *Towards a Theory of Frugal Innovation (February 1, 2012)*, 2012.
- [7] Zeschky, Marco B., Stephan Winterhalter, and Oliver Gassmann. "From cost to frugal and reverse innovation: Mapping the field and implications for global competitiveness." *Research-Technology Management* 57.4: 20-27, 2014.
- [8] Radjou, Navi, and Jaideep Prabhu. *Frugal Innovation: How to do more with less*. The Economist, 2015.
- [9] Radjou, Navi, Jaideep Prabhu, and Simone Ahuja. *Jugaad innovation: Think frugal, be flexible, generate breakthrough growth*. John Wiley & Sons, 2012.
- [10] Wohlfart, Liza, et al. "Corporate and grassroot frugal innovation: a comparison of top-down and bottom-up strategies." *Technology Innovation Management Review* 6.4: 5-17, 2016.
- [11] Tirkolae, Erfan Babae, et al. "Multi-objective optimization for the reliable pollution-routing problem with cross-dock selection using Pareto-based algorithms." *Journal of Cleaner Production* 276: 122927, 2020.
- [12] Tirkolae, Erfan Babae, et al. "A novel model for sustainable waste collection arc routing problem: Pareto-based algorithms." *Annals of Operations Research* : 1-26, 2022.
- [13] Babae Tirkolae, Erfan, et al. "A hybrid augmented ant colony optimization for the multi-trip capacitated arc routing problem under fuzzy demands for urban solid waste management." *Waste management & research* 38.2: 156-172, 2020.
- [14] Goli, Alireza, Erfan Babae Tirkolae, and Mehdi Soltani. "A robust just-in-time flow shop scheduling problem with outsourcing option on subcontractors." *Production & Manufacturing Research* 7.1: 294-315, 2019.
- [15] Tirkolae, Erfan Babae, Parvin Abbasian, and Gerhard-Wilhelm Weber. "Sustainable fuzzy multi-trip location-routing problem for medical waste management during the COVID-19 outbreak." *Science of the Total Environment* 756: 143607, 2021.
- [16] Harris, Matthew, et al. "Fast and frugal innovations in response to the COVID-19 pandemic." *Nature Medicine* 26.6: 814-817, 2020.
- [17] Giones, Ferran, et al. "Revising entrepreneurial action in response to exogenous shocks: Considering the COVID-19 pandemic." *Journal of Business Venturing Insights* 14 (2020): e00186.
- [18] Christopher, Martin, and Helen Peck. "Building the resilient supply chain.", 2004.
- [19] Lenort, Radim, and Pavel Wicher. "Agile versus resilient supply chains: commonalities and differences." *Carpathian logistics congress*. 2012.
- [20] Wicher, Pavel, and Radim Lenort. "The ways of creating resilient supply chains." *Proceedings of CLC: Carpathian Logistics Congress*. 2012.
- [21] Tang, Christopher S. "Robust strategies for mitigating supply chain disruptions." *International Journal of Logistics: Research and Applications* 9.1: 33-45, 2006.
- [22] Iakovou, Eleftherios, Dimitrios Vlachos, and Anastasios Xanthopoulos. "An analytical methodological framework for the optimal design of resilient supply chains." *International Journal of Logistics Economics and Globalisation* 1.1: 1-20, 2007.
- [23] Sheffi, Yossi, and James B. Rice Jr. "A supply chain view of the resilient enterprise." *MIT Sloan management review* 47.1: 41, 2005.
- [24] Esca, <https://www.esca.ma/blog/linnovation-demystifiee-innovez-aujourd'hui-grace-a-linnovation-frugale/>, 15/02/2021.



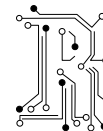

# Impact of Covid-19 on Employees Transportation in Morocco: Optimization using OCVRPTW

Anas Laassiri<sup>1\*</sup>, Abdelfettah Sedqui<sup>2</sup>

<sup>1</sup> Innovative Technologies Laboratory, Abdelmalek Essaadi University, National School of applied sciences of Tangier, Tangier, Morocco; [0000-0003-3692-4216](https://doi.org/10.55185/researcher.1210785)

<sup>2</sup> Innovative Technologies Laboratory, Abdelmalek Essaadi University, National School of applied sciences of Tangier, Tangier, Morocco; [0000-0002-7446-0400](https://doi.org/10.55185/researcher.1210785)

\*Corresponding Author: [laassiri.anas@gmail.com](mailto:laassiri.anas@gmail.com)

Received: 28 November 2022; Accepted: 13 December 2022

**Reference/Atf:** A. Laassiri, A. Sedqui, "Impact of Covid-19 on Employees Transportation in Morocco: Optimization using OCVRPTW", Researcher, vol. 02, no. 02, pp. 106-117, Dec. 2022, doi: 10.55185/researcher.1210785

## Abstract



This Study aims to show the impact of covid-19 on employees' transportation in Morocco, particularly in industrial field, the daily routes between homes and workplace. Moroccan government is led to make strong decisions unexpectedly with immediate turnaround time depending on pandemic state in function of the propagation speed of the virus and its mutated versions and capacity of the health ministry to hold the active and serious cases. These decisions should be made taking into consideration the economic situation, defining restriction to manage the pandemic situation and at the same time avoid hindering of slowing the industrial activity. The frequency of changing the restrictions is not known, it is revealed at unexpected time which make the transportation planning a difficult task. Besides, these decisions have huge impact on transport management for both sides, companies, and service providers. Through this work we will quantify the impact of restrictions on transport budget (20% up to 96% of increase) and propose a decision-making tool to plan daily routes of vehicles using a sequential coupling of vehicle routing problem (VRP) and Bin packing problem in a real case study. This tool have allowed to limit the increase of budget by optimizing the routing process.

**Keywords:** covid-19, vrp, bin-packing, transport management

## 1. Introduction

Covid 19 is among the highly contagious respiratory disease around the world. In Morocco the first case was detected on 2 March 2020 and since then, the country has launched a state of emergency which lasts until these lines are written. Morocco has experienced total confinement for several months, and to lift this confinement it has taken barrier and restriction measures to control the pandemic situation. We find that public transport and employee transportation are the highly impacted sectors due to these decisions. In function of the pandemic situation the government authorizes a maximum capacity load of vehicles switching from 50% up to 100% in all means of transport with the respect of distancing and regular disinfection. This rate have direct impact on transportation cost which is likely to increase. In the literature, the problem of the transport of employees arouses a strong interest from the researchers in logistics, it is seen as a NP-Hard problem because it stands for a variant of Vehicle Routing Problem (VRP) that can be shared into two sub-problems: routing & scheduling (mixture between Traveling Salesman Problem (TSP) & Bin-packing). Each point of pickup must be visited once and served by the same vehicle & the vehicles don't have to come back to the company knowing that the fleet is not in its propriety, this model is called an Open VRP, in which all vehicles follow a Hamiltonian path rather than a Hamiltonian cycle in the case of the real VRP. They pick up employees from their home and drive them back using the same path.

The rest of this paper is organized as follows; we will present the important phases of the pandemic in Morocco and the decisions taken regarding the speed of propagation of the virus, then approach the state of art regarding the VRP and its variances, then, the problem and formulation. We will propose a resolution demarch to quantify the impact of those decisions on transportation budget using OCVRP model. By the end we will discuss the obtained results and conclude the subject

This document is the manuscript template of Ankara Science University, Researcher. With this template, we provide the recommended structure and specific styles for the formatting of the manuscript. Author(s) should use these specific styles for each part (for example title, abstract, keyword, etc.) of the manuscript. Besides being a template, this document includes information about the formatting of your work.

### 1.1 Pandemic numbers in Morocco

The fight against the spread of the Covid19 virus has forced all states to take urgent and exceptional measures to face the risks that the World Organization Health has called it a pandemic. The Kingdom of Morocco has reacted proactively and has taken several decisions to this effect according to current pandemic situation (from Rapport du Conseil Economique, Social et Environnemental/Conseil Economique Social et Environnemental du Royaume du Maroc (cese.ma))

- 09/03/2020 Border closures
- 13/03/2020 Closure of schools and universities
- 14/03/2020 Ban on all public gatherings of more than 50 people
- 16/03/2020 Closure of public places
- 20/03/2020 Declaration of health emergency
- 21/03/2020 Travel prohibition between cities- Suspension of rail lines
- 07/04/2020 Introduction of compulsory mask wearing
- 23/04/2020 No night-time travel during the month of Ramadan from 7:00 p.m. to 5:00 a.m. except for people working in specific sectors
- 11/06/2020 Gradual lifting of containment and distribution of the national territory into 2 zones 1 and 2 with different relief from restrictions.

The gradual lifting of the lockdown began with an authorization of 50% of the capacity of public and private transport, then 75% and after total easing of the restrictions, the state authorized a capacity of 100%. However, this decision is not stable over time, you can go straight back to 50% after being at 100%. Each change in authorized occupancy rate generates a new organization of staff transport, their allocated budget, etc. Hence the need for robust route planning to meet state restrictions in the 'state of emergency' phase. Then quantify the financial impact to see the possibility of integrating it into the framework of the major forces and having support funds from the state. Finally, it is imperative to have improved responsiveness since the time between the announcement of decisions and their execution does not exceed 24 hours. The government's latest extension decision of emergency state is set to expire on November 30/2021 (a total duration of 18 months), but it was extended again before it expired which is becoming a common decision of the government to curb the spread of the COVID-19.

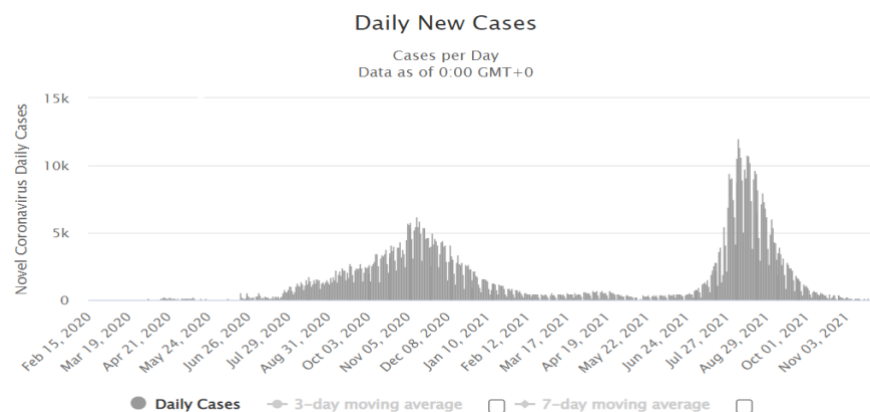

Figure 1: daily covid cases in Morocco

## 1.2. State of art

The Vehicle Routing problem is a class of the combinatorial optimization problems that has drawn much research attention, it was introduced first by [1] and it is one of the NP-Hard problem [2] [3] [4]. VRP has more than 20 variants, the objective is to define routes for vehicles to serve customer demands; this is expressed by the following parameters:

- An edged weighted directed graph:  $G = (V, A)$ , where  $V$  is the set of customers, including the also the depot, and  $(A)$  is the set of arcs.
- The weighting function that defines the cost between an arc  $i$  and  $j$  (distance of travel or duration).

Since the work of [1], there was different applications of VRP in the literature. Particularly, the Capacitated VRP (CVRP), the vehicles must respect the constraint of capacity. The VRPTW the vehicle routing problem with time windows, the vehicles have the constraint of the total travel time or the driving hours. The transport of employee is one of its special applications which are similar to the bus routing problem introduced by [5] and it is an application of the well-known Open capacitated vehicle problem, that was firstly solved by [6] where vehicles don't have to return to the depot and follow a Hamiltonian path described also as NP-Hard [7]. We can find an optimal solution for small instances using exact methods, but if we consider a big instance, we have to opt for an approximate method to have a solution that is near to the optimal and with a good quality.

## 2. Problem: Formulation and modelling

### 2.1. Assumptions and objectives

Through this work, we aim to define a model to:

- Develop a dynamic model solving the scheduling and routing of the transport of employees in pandemic situation,
- Respect the restriction of Covid 19 in terms of capacity and evaluate the impact.
- Respect the total route duration: 45 Min.
- Optimize the daily routes travelled by vehicles.

The assumptions considered for the treatment of this problem are as follows:

1. The service provider has a homogenous fleet.
2. We have various pick-up points.
3. The management constraints are the global route time, the capacity of the bus and the number of used vehicles.
4. The route of each vehicle can be modified for the reasons below:
  - a. Resignation/ Recruitment.
  - b. Shift rotation.
  - c. Extra hours/ Special events.
  - d. Modification of restrictions by government
5. No new transport request arrives when executing the assignment problem.
6. Each bus has only one route for transporting employees to the company in the morning and driving them back to their home after working hours.
7. If the bus visiting a pickup point it must pick up all the employees at that point.
8. The driving time of the bus from one pick up point to another includes jams, road condition, and waiting time in traffic light, those data are extracted from a GIS web system.

9. Each pick up point is assigned to only one vehicle.

10. The model developed will yield just a one-sense itinerary: from the company to initial pick-up points, knowing that a single bus follows the same path, but in a reverse way.

The assumptions 1,4,5,6,9,10 are counted as limits of the method proposed.

## 2.2. Problem formulation

To formulate our COVRPTW problem, we present a mixed integer programming model that aims to maximize the net profit, by maximizing the load of the bus times the united cost, minus the total trip cost. All variable and parameters are summarized in the table below:

To formulate our COVRPTW problem, we present a mixed integer programming model that aims to maximize the net profit, by maximizing the load of the bus times the united cost, minus the total trip cost. All variable and parameters are summarized in the table below:

Table 1. Problem variabes

Variable	Description
$V_D$	The set vertex of depot
$V_C$	The set vertex of customers (employee)
$G=(V, A)$	Complete directed network $V = V_D \cup V_C$
$p_i$	Cost of picking up a customer $i \in V_C$
$q_i$	Pick up amount for the customer $i \in V_C$
$\wedge q_i$	The delivery amount for a customer $i \in V_C$
$S_i$	Service time for the customer $i \in V_C$
$[a_i, b_i]$	Time interval for the customer $i \in V_C$
$K$	The set of vehicles $k \in K$
$o^k$	The origin depot for the vehicle $k, o^k \in V_D$
$T^k$	Work start time for the vehicle $k \in K$
$f^k$	Fixed cost using the vehicle $k \in K$
$Q^k$	The capacity of the vehicle $k \in K$
$D^k$	The distance limit of the vehicle $k \in K$
$\wedge D^k$	Driving time limit for the vehicle $k \in K$
$W^k$	Working time limit for the vehicle $k \in K$
$d_{i,j}$	Distance associated with the arc $(i, j) \in A$
$\wedge d_{i,j}$	Driving duration associated with the arc $(i, j) \in A$
$C_{i,j}^k$	Travel cost on the arc $(i, j) \in A$
$x_{i,j}^k$	Decision variable equals 1 if the vehicle $k$ traverses the arc $(i, j) \in A$ ; 0 otherwise
$y_i^k$	Equals 1 if the vehicle $k$ visit $i$ and serve it; 0 otherwise
$w_{i,j}^k$	Pick up number of people carried by the vehicle $k$
$z_{i,j}^k$	Delivery number of people carried by the vehicle $k$
$t_i^k$	Time when $k$ arrives at the vertex $i$

The objective function is defined as:

$$F = MAX \sum_{i \in V_C} \sum_{k \in K} p_i y_i^k - \sum_{(i,j) \in A} \sum_{k \in K} C_{i,j}^k x_{i,j}^k \quad (1)$$

Following are the constraints:

$$\sum y_i^k = 1 \quad \forall i \in V_C \quad (2)$$

$$\sum_{j \in V \setminus \{i\}} x_{i,j}^k \leq \sum_{j \in V \setminus \{i\}} x_{j,i}^k \quad \forall j \in V_C, k \in K \quad (3)$$

$$\sum_{p \in S, q \in V \setminus S} x_{p,q}^k \geq y_i^k \quad \forall i \in V_C, k \in K, o^k \in V; i \in V \setminus o^k \quad (4)$$

$$\sum_{j \in V_C} x_{o^k,j}^k \leq 1 \quad \forall k \in K \quad (5)$$

$$\sum W_{i,j}^k - \sum W_{j,i}^k = q_i y_i^k \quad \forall i \in V_C, k \in K \quad (6)$$

$$\sum_{i \in V_C} W_{i,i}^k = \sum_{j \in V_C} q_j y_j^k \quad \forall i \in V_C, k \in K \quad (7)$$

$$\sum_{j \in V \setminus \{i\}} z_{j,i}^k - \sum_{j \in V \setminus \{i\}} z_{i,j}^k = \wedge q_i y_i^k \quad \forall k \in K \quad (8)$$

$$\sum_{i \in V_C} z_{o^k,j}^k = \sum_{i \in V_C} \wedge q_i y_i^k \quad \forall k \in K \quad (9)$$

$$w_{ij}^k + z_{ij}^k \leq Q^k \quad \forall (i,j) \in A; k \in K \quad (10)$$

$$t_{o^k}^k = T^k \quad \forall k \in K \quad (11)$$

$$\sum_{i,j} d_{ij} x_{ij}^k \leq D^k \quad \forall (i,j) \in A, k \in K \quad (12)$$

$$\sum_{i,j} \wedge d_{ij} x_{ij}^k \leq D^k \quad \forall (i,j) \in A, k \in K \quad (13)$$

$$\sum_{i \in V_C} S_i y_i^k + \sum_{i,j} \wedge d_{ij} x_{ij}^k \leq W^k \quad \forall (i,j) \in A, k \in K \quad (14)$$

$$x_{i,j}^k \in \{0,1\} \quad \forall (i,j) \in A, k \in K \quad (15)$$

$$y_i^k \in \{0,1\} \quad \forall i \in V_C, k \in K \quad (16)$$

$$w_{i,j}^k \geq 0; z_{i,j}^k \geq 0 \quad \forall (i,j) \in A, k \in K \quad (17)$$

• The function objective (1) tends to maximize the net profit; it contains a conflict between maximizing the load and minimizing the cost of usage. In fact, this objective function tends to amortize the cost paid by the company to ensure the transport, the maximum value of the objective function in our case will be 0, this means that the vehicle was fully loaded, and the cost was amortized.

• The constraint (2) ensures that a customer is visited just once.

• The constraint (3) ensures an inflow if there is an outflow (flow conservation).

- The constraint (4) ensures the connectivity between the customers visited and the depot.
- The constraint (5) ensures that each vehicle can be used just once.
- The constraint (6) & (7) ensure the flow conservation for pickup commodity.
- The constraint (8) (9) ensure the flow conservation for delivery commodity.
- The constraint (10) ensures the respect of vehicle capacity according to government decision.
- The constraint (11) ensures the working start for the vehicle.
- The constraint (12) (13) & (14) define respectively the distance, driving time, and working time limit.
- The constraint (15), (16), (17) ensure non negativity and integrity.

This model is valid only for small instances knowing that in our case we are facing a NP-Hard problem, thereby; it must be solved using approximate methods already proven their efficiency. We aim to have a simple and robust model with reasonable time of compilation, we will use the spreadsheet developed by Güneş Erdoğan with some modification related to our context:

Phase 1: Defining pick up points: Clustering of employees

- Forming the pick-up points using two steps clustering algorithm.

Phase 2: Routing

- Route construction using Local Neighbourhood Search (LNS).and Clark & Wright principle.
- Feasible solution maximizing the net profit.

Phase 3: Improvement

- Improvement of the solution using LNS incorporating the improvement heuristics: 2-Opt, Exchange (vehicle, routes), Remove/Add vertices.

### 3. Case Study

#### 3.1. Input Data:

We will apply the model developed in a real case study from the automotive industry, bellow we have all the input data:

Table 2: The input data of the case study

Number of employees	80
Coordinates of each employee	X, Y issued from Bing map
Cost of pickup for one employee	10 MAD
Distances	issued from GIS WEB
Duration of travel between employees	issued from GIS WEB
Number of vehicles	8 (current)
Cost/Trip	190 MAD
Capacity	19
Total travel time limit	45 min + Flexibility of 5 min
Service time for each stop	15 s
Work starts time (Morning shift)	7:00 A.M
Arrival time preference (Morning shift)	Before 8:00 A.M

Pickup points and number of employees:

Table 1: Detail of pick-up points

ID	Pick up Description	X	Y	Number of Employees
0	Company	35,715639	-5,92679	
1	Quartier AOUAMA	35,725405	-5,80445	4
3	Quartier AZIB	35,743706	-5,84431	4
4	Quartier Ben Diban	35,758756	-5,818516	1
5	Quartier Barnes	35,760307	-5,832528	3
6	Quartier Casa barata	35,766376	-5,824878	5
7	Quartier 7 village	35,762965	-5,844532	1
8	Complexe - Moustakbal	35,73412	-5,870079	3
9	Complexe - Nour	35,730375	-5,853235	3
10	Complexe el Hassani	35,735574	-5,858088	1
11	Quartier Daradeb	35,785505	-5,831259	4
12	Quartier Marjane	35,745838	-5,849469	3
13	Quartier Achakar	35,737182	-5,885006	1
14	Quartier Boukhalef	35,736764	-5,878639	1
15	Quartier Doha Marjane	35,749527	-5,847284	3
16	Quartier Drissia	35,757445	-5,805427	5
17	Quartier Girari	35,746414	-5,807998	3
19	Quartier Gzenaya	35,708051	-5,907357	3
20	Quartier Mghougha	35,759335	-5,790931	2
21	McDonald Marjane	35,744725	-5,843763	7
22	Quartier Mesnana	35,756984	-5,852997	2
23	Quartier place de ville	35,775301	-5,810942	3
24	Quartier Souani	35,770353	-5,825248	4
25	Quartier Sidi Driss	35,742331	-5,831769	1
26	Quartier Tanger Balia	35,772204	-5,770773	6
27	Quartier Val Fleuri	35,765797	-5,834518	1
28	Quartier Zemmouri	35,741341	-5,86805	4
29	Quartier Kharba	35,752539	-5,84642	2

According to Bing map, this is the distribution of pickup points and destination (company's address) in the map:

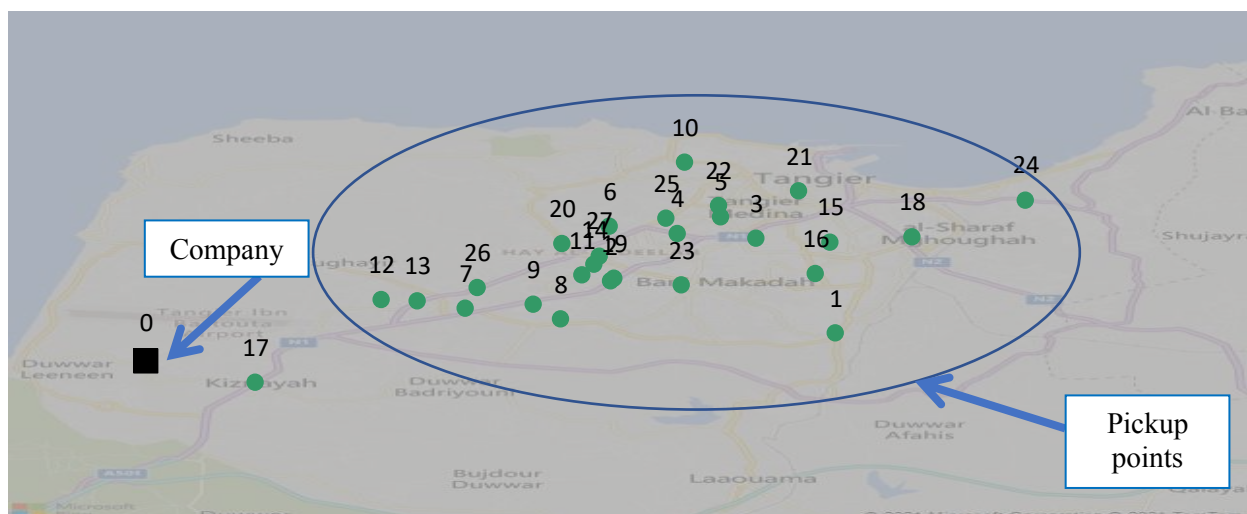

Figure 2: The distribution of pickup and delivery points

**3.2. Computational results: COVRPTW with 100% capacity:**

After 6800 iterations we obtain the results bellow:

Table 4: Summary of computational results: 100% capacity

Vehicle	Number of stops	Distance travelled	Driving time	Arrival time (company)	Working time	Load of the vehicle	Objective function
V1	2	7,85 km	16 min	7:16 AM	16 min	6	-130 MAD
V2	9	18,01 km	45 min	7:47 AM	47 min	19	0 MAD
V3	6	17,14 km	43 min	7:44 AM	44 min	19	0 MAD
V4	5	23,30 km	43 min	7:44 AM	44 min	18	-10 MAD
V5	5	15,89 km	43 min	7:44 AM	44 min	18	-10 MAD
V6	-	-	-	-	-	-	-
V7	-	-	-	-	-	-	-
V8	-	-	-	-	-	-	-

We need only 5 vehicles of 8 in the fleet. We obtain results that satisfy our constraints, and with a minimum load of 31% and maximum 100%, the mean value is acceptable: 84% this means that for each travel, on average 84% of costs are amortized. Knowing that for 4 travels of 5, we amortize 97% of transport costs. The driving time does not exceed 45 min adding maximum 5 minutes of service, based on the duration and distance issued from BING map, all vehicles arrive before 8h00 which is the stating working hour for administration staff. The map bellow shows the itinerary of each vehicle from the furthest pick up zone, up to the company:

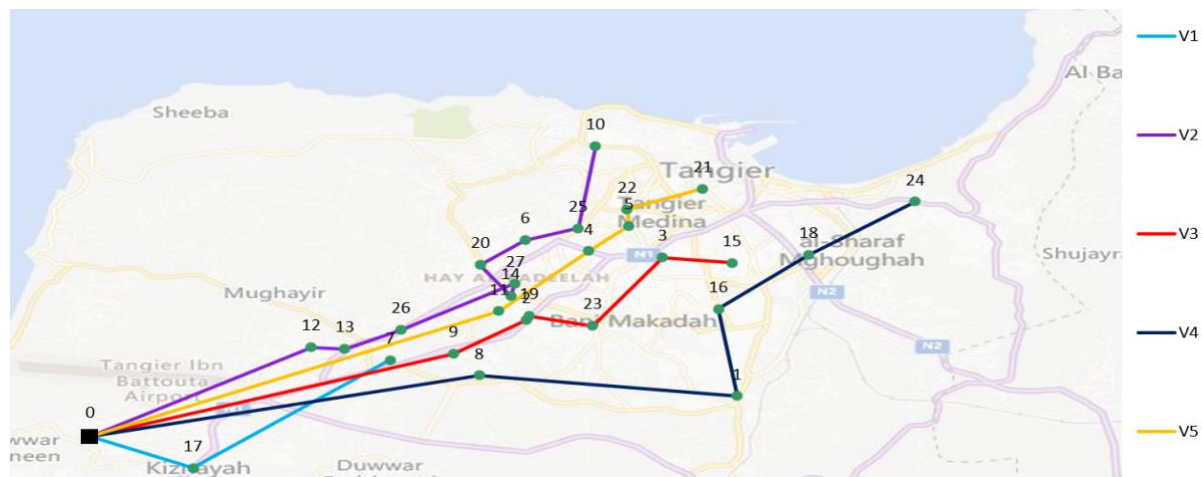

Figure 3: Routes in the case of 100% capacity

**3.3. Computational results: COVRPTW with 75% capacity:**

After 6089 iterations we obtain the results bellow:

Table 5: Summary of computational results: 75% capacity

Vehicle	Number of stops	Distance travelled	Driving time	Arrival time (company)	Working time	Load of the vehicle	Objective function
V1	4	20,06 km	44 min	7:45 AM	45 min	14	-50 MAD
V2	4	10,58 km	23 min	7:24 AM	24 min	10	-90 MAD
V3	4	20,19 km	40 min	7:40 AM	41 min	14	-50 MAD
V4	7	16,19 km	39 min	7:40 AM	40 min	14	-50 MAD
V5	4	13,46 km	36 min	7:27 AM	37 min	14	-50 MAD
V6	4	13,04 km	26 min	7:27 AM	27 min	14	-50 MAD
V7	-	-	-	-	-	-	-
V8	-	-	-	-	-	-	-



For 75% of capacity restriction equivalent to 14 seats, we need an additional vehicle, the number becomes 6 vehicles of 8 in the fleet (increase of transport budget of 20%). We obtain results that satisfy our constraints, and with a minimum load of 71% and maximum 100%, the mean value is acceptable: 95%. Although using only 75% of capacity, we pay full cost trip. The driving time does not exceed 45 min adding maximum 5 minutes of service, based on the duration and distance issued from BING map. All vehicles arrive before 8h00 which is the starting working hour for administration staff. The map bellow shows the itinerary of each vehicle from the furthest pick up zone, up to the company

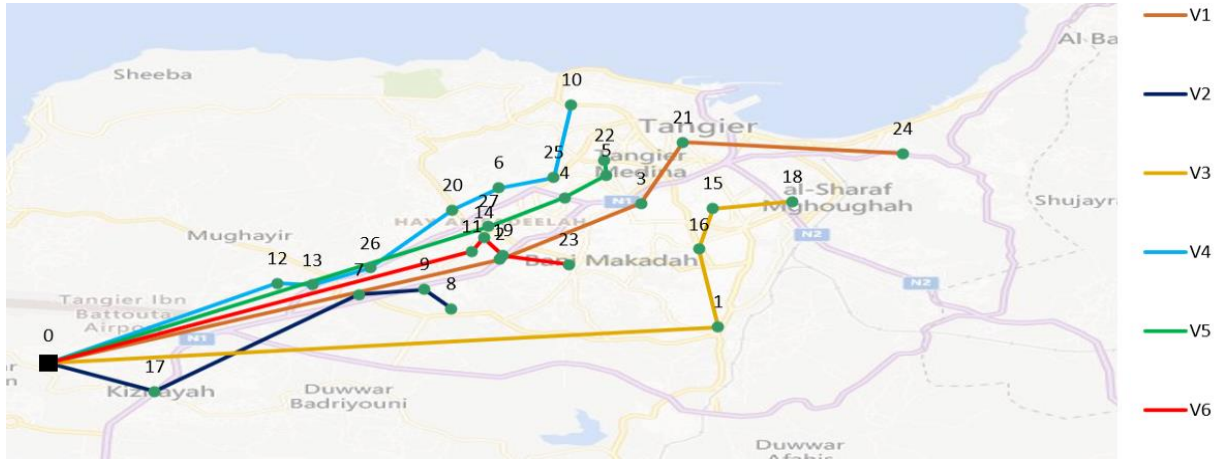

Figure 4: Routes in the case of 75% capacity

### 3.4. Computational results: COVRPTW with 50% capacity:

After 5992 iterations we obtain the results bellow:

Table 6: Summary of computational results: 50% capacity

Vehicle	Number of stops	Distance travelled	Driving time	Arrival time (company)	Working time	Load of the vehicle	Objective function
V1	2	10,11 km	19 min	7 :19 AM	19 min	8	-110 MAD
V2	3	10,82 km	21 min	7 :21 AM	21 min	9	-100 MAD
V3	2	17,18 km	29 min	7 :29 AM	29 min	9	-100 MAD
V4	3	16,47 km	40 min	7 :40 AM	40 min	9	-100 MAD
V5	3	15,81 km	36 min	7 :27 AM	36 min	9	-100 MAD
V6	4	17,16 km	38 min	7 :39 AM	39 min	9	-100 MAD
V7	3	10,15 km	21 min	7 :21 AM	21 min	9	-100 MAD
V8	4	12,61 km	29 min	7 :30 AM	30 min	9	-100 MAD
V9	3	19,28 km	39 min	7 :39 AM	39 min	9	-100 MAD

For 50% of capacity restriction equivalent to 9 seats only, we need four additional vehicles, the number becomes 9 vehicles versus 8 in the fleet (increase of transport budget of 80%). We obtain results that satisfy our constraints with a minimum load of 89% and a maximum of 100%, the mean value is acceptable: 99%. Although using only 50% of capacity, we pay full cost trip. The driving time does not exceed 45 min adding maximum 5 minutes of service, based on the duration and distance issued from BING map. All vehicles arrive before 8h00. The map bellow shows the itinerary of each vehicle from the furthest pick up zone, up to the company:

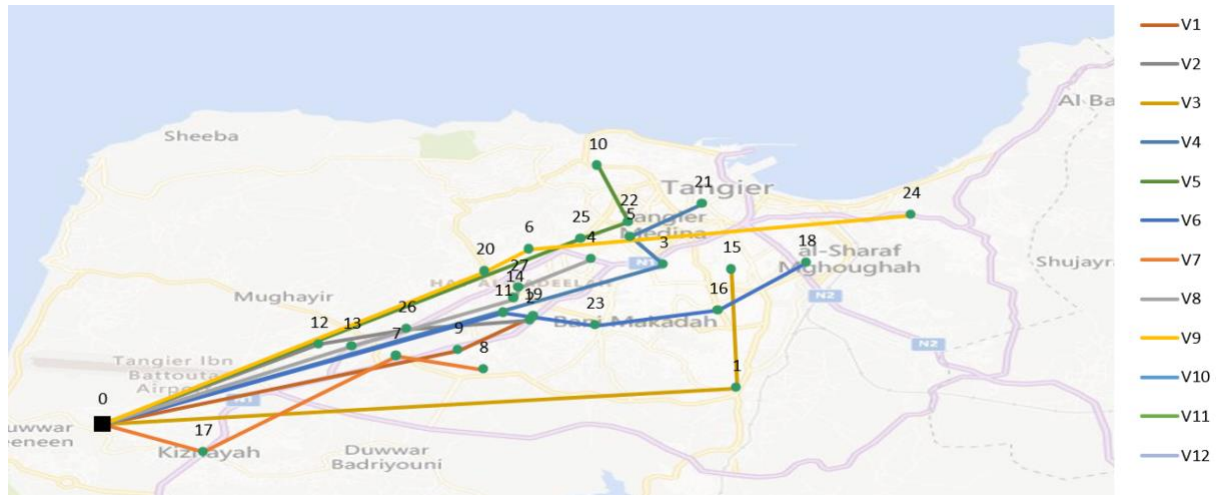

Figure 5: Routes in the case of 50% capacity

#### 4. Discussion and Synthesis

After obtaining the simulation data of the two scenarios. The tables below summarize the results obtained with full capacity, then 75% capacity and finally 50%, and the impact of each capacity restriction on transport budget. it is necessary to mention that without this tool, the company couldn't supervise the transport cost and the daily routes before Covid19 (100% of capacity), and couldn't quantify the impacts of Post covid19 (75% and 50% capacity restriction) compared to normal situation:

Table 7: Synthesis of Results: Objective Function

Vehicle	Objective function			% Cost not amortized		
	Scenario 100%	Scenario 75%	Scenario 50%	Scenario 100%	Scenario 75%	Scenario 50%
V1	-130 MAD	-50 MAD	-110 MAD	68%	26%	58%
V2	0 MAD	-90 MAD	-100 MAD	0%	47%	53%
V3	0 MAD	-50 MAD	-100 MAD	0%	26%	53%
V4	-10 MAD	-50 MAD	-100 MAD	5%	26%	53%
V5	-10 MAD	-50 MAD	-100 MAD	5%	26%	53%
V6	-	-50 MAD	-100 MAD	-	26%	53%
V7	-	-	-100 MAD	-	-	53%
V8	-	-	-100 MAD	-	-	53%
V9	-	-	-100 MAD	-	-	53%

Table 8: Synthesis of results: Budget impact

Vehicle	% Load based on current authorized load			% Load based on total capacity		Budget Impact %	
	Scenario 100%	Scenario 75%	Scenario 50%	Scenario 75%	Scenario 50%	Scenario 75%	Scenario 50%
V1	32%	100%	89%	74%	42%		
V2	100%	71%	100%	53%	47%		
V3	100%	100%	100%	74%	47%		
V4	95%	100%	100%	74%	47%		
V5	95%	100%	100%	74%	47%	+20%	+96%
V6	-	100%	100%	74%	47%		
V7	-	-	100%	-	47%		
V8	-	-	100%	-	47%		
V9	-	-	100%	-	47%		

- In the scenario of full capacity, the simulation gives good quality results, with only 16% of total costs that are not amortized, and a maximized load rate for four vehicles. The rest of employees were assigned to the last vehicle. This proves the strength of the model developed.
- In the scenario of 75% capacity restriction, the total costs not amortized becomes 30%, the load rate is maximized and balanced. The company must add one vehicle to ensure all routes, the financial impact of this decision compared to the initial budget (100% capacity) is 20% of increase.
- In the scenario of 50% capacity restriction, the total costs not amortized becomes 53%, the load rate is maximized and balanced because for the model developed the capacity constraint was slightly relaxed. The company must add four vehicles to ensure all routes, the financial impact of this decision compared to full capacity budget is almost doubled the budget, about 96% of increase.

The model developed allowed to optimize the daily routes by, first, regrouping employees into clusters to reduce the pickup points. Then by creating routes under an objective function which tend to amortize the cost paid by the company for transporting each employee from his home up to the company and vice versa. This could be identified through the results of simulation, except the last bus in the fleet, all buses have maximum load in the routes defined. Finally, by permitting the company to adjust the capacity of bus in order to abide by the restrictions set by the authorities in order to flatten the pandemic curve. Function of restrictions, which changes frequently. The dynamism degree of the model in addition to the results obtained were very satisfying.

## 5. Conclusion and perspectives

The model developed is dynamic and will serve as a decision-making tool in strong term. It gives good results under all the constraints defined at the beginning, regarding the capacity restriction, total route time and total net profit maximization. All the constraints were satisfied, and initial specifications were respected. It is also relevant to highlight the computing rapidity which is required for such situation of instant decision imposed by the government. After the simulation considering the different capacity restrictions due to Covid19, the results show that the impact of the pandemic is obvious on transport, and particularly in the transport of employee, these restrictions have direct impact on allowed transport budget, and swings from 20% to 96% of increase in function of the pandemic situation of the country.

For further work of research, we aim to minimize the total net profit to give companies more agility to face such pandemic situations which we will probably face in the future. We will propose a new model including a preliminary clustering before assignment to minimize the number of pick-up points and thus, minimize the total route time. Even though these two goals seem contradictory.

## Acknowledgments

I would like to express my gratitude to my primary supervisor, of thesis Abdelfettah Sedqui, who guided and assisted me throughout this work of research. I would also like to thank the logistics manager of the multinational company for the data, support, and the trust. A special thanks for my wife and family who supported me during this work till the redaction of these lines. I would like to thank also the two anonymous reviewers whose constructive and helpful comments have helped considerably in improving the contents as well as the presentation of the paper.

## Contribution of Researchers

All researchers have contributed equally to writing this paper.

## Conflicts of Interest

The authors declare no conflict of interest.

## References

- [1] G. B. Dantzig et J. H. Ramser, "The Truck Dispatching Problem", *Manag. Sci.*, vol. 6, no 1, p. 80-91, 1959.
- [2] M. W. P. Savelsbergh et M. Sol, "The General Pickup and Delivery Problem", *Transp. Sci.*, vol. 29, no 1, p. 17-29, févr. 1995, doi: 10.1287/trsc.29.1.17.
- [3] Christofides et al. "1979-VRP-REP: the vehicle routing problem repository". [En ligne]. Disponible sur: <http://www.vrp-rep.org/references/item/christofides-et-al-1979.html>. [Consulté le: 26-févr-2020].
- [4] J. B. Lenstra et A. H. G. R. Kan, "Complexity of vehicle routing and scheduling problems", *Networks*, 1979, doi: 10.1002/net.3230110211.
- [5] B. T. Bennett, "School Bus Routing by Computer", p. 1.
- [6] D. Sariklis et S. Powell, "A heuristic method for the open vehicle routing problem", *J. Oper. Res. Soc.*, vol. 51, no 5, p. 564-573, mai 2000, doi: 10.1057/palgrave.jors.2600924.
- [7] M. Michalski, "Discrete optimization algorithms with pascal programs" M. M. Syslo (Universität Bonn, Federal Republic of Germany), N. Deo (Washington State University, Pullman, Washington), J. S. Kowalik (Washington State University, Pullman, Washington). Prentice-Hall. Inc., Englewood Cliffs, N. J., 1983, xii + 542 pp., *Rep. Math. Phys.*, vol. 22, no 2, p. 293-294, 1985, doi: [https://doi.org/10.1016/0034-4877\(85\)90055-2](https://doi.org/10.1016/0034-4877(85)90055-2).
- [8] I. H. Dridi, "Optimisation heuristique pour la résolution du m-PDPTW statique et dynamique", p. 224.
- [9] P. Oliveira et A. P. Barbosa-Póvoa, "School Bus Routing and Scheduling: a Real Case Study", p. 39.
- [10] T. Pichpibul et R. Kawtummachai, "A Heuristic Approach Based on Clarke-Wright Algorithm for Open Vehicle Routing Problem", *Sci. World J.*, vol. 2013, p. 1-11, 2013, doi: 10.1155/2013/874349.
- [11] J. BRACA, J. BRAMEL, B. POSNER, et D. SIMCHI-LEVI, "A computerized approach to the New York Cityschool bus routing problem", *IIE Trans.*, vol. 29, no 8, p. 693-702, août 1997, doi: 10.1023/A:1018526202990.
- [12] R. M. Newton et W. H. Thomas, "Bus routing in a multi-school system", *Comput. Oper. Res.*, vol. 1, no 2, p. 213-222, août 1974, doi: 10.1016/0305-0548(74)90047-1.
- [13] R. Bowerman, B. Hall, et P. Calamai, "A multi-objective optimization approach to urban school bus routing: Formulation and solution method", *Transp. Res. Part Policy Pract.*, vol. 29, no 2, p. 107-123, Mars 1995, doi: 10.1016/0965-8564(94)E0006-U.
- [14] D. Ripplinger, "Rural School Vehicle Routing Problem", *Transp. Res. Rec.*, vol. 1922, p. 105-110, janv. 2005, doi: 10.3141/1922-14.

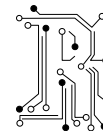

## COVID-19: Perceptions of public transit passengers on its management and influence on sustainable transport in Ibadan

Adeyinka Ajayi<sup>1\*</sup>

<sup>1</sup>Redeemer's University: Ede, Osun, NG; ORCID: [0000-0002-9031-7444](https://orcid.org/0000-0002-9031-7444)

\* Corresponding author: [ajayia@run.edu.ng](mailto:ajayia@run.edu.ng)

Received: 21 December 2022; Accepted: 27 December 2022

**Reference/Atf:** Adeyinka Ajayi, "COVID-19: Perceptions of public transit passengers on its management and influence on sustainable transport in Ibadan", Researcher, vol. 02, no. 02, pp. 46-56, Dec. 2022, doi: 10.55185/researcher.1222307

### Abstract



This research is an empirical assessment of how the outbreak of Covid-19 impacted the public transit system and the achievement of sustainable public transport during the period of partial restriction in Ibadan. Multistage and random sampling techniques were used in selecting 181 participants for the study. Two hypotheses were tested, results from the first regression model showed the five selected socioeconomic variables and dreadful perception of the public transit system as an epicenter of the contagion by the passengers explained a moderate 52% of the variance and was a significant determinant of public transit usage during the studied period ( $R^2 = .052$ ,  $F(6,175) = 7.6$ ,  $p < .005$ ). Furthermore, the regression model for the second hypothesis which explained a paltry 24% variance revealed that respondents' trip decisions during the period of the partial lockdown were not significantly determined by their belief in the government-formulated measures against the pandemic, safety practices deployed in the management of public transit system, their economic situations and their desires to help in the achievement of sustainable urban transport ( $R^2 = .024$ ,  $F(6,175) = 1.63$ ,  $p > .005$ ). The paper presents a novel attempt that aid the understanding of the dynamics between the SES of passengers using the public transit system, and the management of an outbreak of public health emergencies.

**Keywords:** covid-19, socioeconomic situation, public transit management, dreadful perception, public health emergency, sustainable transport.

### 1. Introduction

Nigeria, Africa's biggest economy got a rude awakening to the calamitous effects of COVID-19 on the lives of its nationals, fragile economy, and weak public institutional infrastructures when the first incidence case of the disease was discovered in the country on the 28th of February 2020 [1]. As should be expected for a country that is densely populated (over 200 million estimated population) saddled with a public health system in a deplorable state, with a disproportional percentage of its working-class either unemployed or underemployed: the harsh reality of the pandemic on the shores of the country elicited morbid fears among all stakeholders. The fear expressed was not in the least unfounded because of certain realities: two of the most popular containment methods against the covid-19 pandemic as outlined by the World Health Organization involve social behavioral changes and Non-Pharmaceutical Interventionist (NPI) approaches.

Some of these are social distancing and lockdown, these two NPI approaches come' with a huge cost to national economies [2]. Implementation of these two measures in severe cases of the pandemic strongly advocates limited or complete cessation of spatial mobility (except for essential services) in cities and even rural communities [2]. The effect of such decisions on developed economies of China, the United States, and the European Union where the number of citizens engaged in the formal employment sector of the labor market surpasses that of those in the informal employment are detailed to include significant negative changes in the troika of the economic indices of investment, consumption, and international trading - all of which led to the loss of jobs [4,56]. Empirical findings from earlier research equally indicated that most informal employees are usually the first and worst hits once 'spatial mobility is curtailed': it is an economic fact that there is a disproportional propensity for workers employed

informally to be more 'mobile' either within an urban space or across regional borders than their counterparts who are engaged in the formal sector in the course of their occupational pursuit [6, 7,8].

A 2018 International Labor Organization-sponsored study revealed that the African region has the highest proportion of its workers in informal employment when the global comparison was made, the region has 85.8 percent of its workforce engaged in the informal sector, the proportion for Asia was 68.2 percent, 40.0 percent in the Latin Americas, while for the more developed economies of the United States and European Union the figure hovered between 15 to 20 percent [9]. This reality formed a huge part of the trepidation for different stakeholders on how Nigerian nationals will maintain the intricate balance between the strict adherence to the COVID-19 WHO containment protocol of movement restriction and the achievement of economic livability.

This is particularly pertinent because a recently released statistic from the Nigeria Bureau of Statistics (NBS) indicated that 56.25% (nearly 71 million) of the Nigerian labor force (workers between the ages of 16 to 64) are employed informally and a huge proportion among them depends on the public transit system as mean of mobility rather than private vehicle ownership [10]. Employees engaged in the "shadow economy" or informally (Packard et al, 2012), have been observed to show a general emotional ambivalence in their reaction towards 'perceived' State overarching regulatory influences on labor practices, first they are 'happy to have the freedom that comes with working for themselves and unhappy 'with regulatory regimes of different State laws which are viewed as undue interferences in their businesses' [6, 9].

Added to this is the fact that discovery from recent research which examined the attitudinal dispositions of most urbanites who experienced mobility restrictions as a result of covid-19 lockdown showed that there is the re-emergence of the "dreadful behavior/perception" which past calamitous events (like SARS, 9/11 terrorist attacks) on transport networks produced in passengers globally [11, 12]. The concept of dreadful behavior as defined in the literature is a "fearful reaction to any calamitous incident which occurred on or near transport facilities and which a fully operational transport system can be a catalyst to its reoccurrence" [11,12]. The combination of these two opposed attitudinal dispositions (citizens being at variance with the government rules restricting movement and at the same time exercising fears on the risk of contracting the pandemic on public transit system) expectedly created a gap worthy of critical examination.

There is also a need to unravel the perception of the users of the public transit system as it relates to issues surrounding the sustainability of government-inspired safety measures rolled out against the spread of the contagion and the effect of such on the achievement of an overall urban transport sustainability goal. Another reality that can be gleaned from findings in recent research is the fact that the interrelationships between operational sustainable safety practices (in public transit systems) imposed by governments and the economic impacts on the livelihoods of nationals across different regions within countries seemingly encouraged the use of private automobiles as against public transit [12, 13, 14, 15, 16, 17]. For example, in Italy, richer regions (where there was an obvious preponderance in the usage of a personal automobile as against mass transit) which incidentally had a higher rate of the incidence of the pandemic at its peak had a lower rate of mobility contraction. While residents of poorer regions that reported a lower rate of the spread of the covid-19 pandemic (at its peak) had a higher level of mobility contraction [14]. A similar situation also played out in Paris, where it was reported that at the peak of the mobility restriction occasioned by the COVID-19 induced lockdown, poorer residents who naturally depend on the public transit system for intra-city mobility reported a near-total mobility contraction and experienced a slower spread of the contagion: a scenario which was a sharp contrast to the situation among car owners [15]. It is observable that the majority of available research conducted on safety practices (mobility contraction arising from the effects of the covid-19 pandemic) have some striking similarities: first, they relied heavily on secondary data [15, 17].

Second, most of these studies emanated from developed economies where the public transit system is highly formalized with a regulatory regime that is an offshoot of the competent eutaxy that often defines such an operational environment. Third, careful observation of most of the available works on the discourse also revealed that there is no deliberate attempt made by investigators to critically examine through empirical research how the mobility contraction occasioned by the covid-19 pandemic affected

the different occupational classes (formalized employees and those in the shadow economy) and also to objectively unravel critical determinants of the continual usage of the public transit system as against private automobiles even with the reality of possible infection of the contagion in the study area.

## 2. Literature Review

There has been an ongoing debate by scholars revolving around what should constitute an agreeable taxonomy for informal employment across the spatiotemporal divides [18, 19, 20, 21]. While it is a truism that the shadow economy has some striking similarities that give the participants in it some degrees of uniformity (generally their activities circumvent or otherwise avoid government regulation, taxation, or observation and, workers in it have higher indices of job turnover/mobility) wherever it is operational. In practice, the characterization of the shadow economy in sub-Saharan Africa (SSA) has some distinctive peculiarities that differentiated its form and daily operational quiddity from what is found in most Western societies.

Firstly, informal employment is the biggest employer in sub-Sahara Africa (with over 80% of the population of the working class in the region being in or another form of informal employment). This contradicts the employment structure in Western societies where employees in the shadow economy are merely small fractions of the entire working class [18, 19, 20, 21]. Secondly, statistics from Europe and the US show that most workers employed in the informal sectors are usually emigrants (mostly illegal immigrants) who both lacked the legally required immigration status to apply for formal jobs and who sometimes also are bereft of basic educational/professional certification to pick up formal employment [22, 19, 21].

The situation is different in most countries in the SSA region where a significant number of those employed in the shadow economy are nationals of their respective countries with a reasonable level of educational/professional training which should otherwise guarantee their employability into the formal employment category [21]. Kiaga et al, (2020) rightly observed that “there is little distinction between workers in the formal and informal labor sectors in SSA” (when educational qualification is used as a parameter). It is with the knowledge of the foregoing that analysts posited that workers in the shadow economy in SSA could be the fulcrum of the fight against the spread of the COVID-19 pandemic [2, 21]. Added to these salient observations are also the realities that research findings have shown that workers in the shadow economy in SSA are rarely captured in National Health Insurance Schemes (NHIS) and that their economic survival is strongly tied to being highly mobile, particularly where are beehives of human activities – urban markets, Central Business Districts, bus stations/motor parks [21]. As unearthed in the course of this study, without the medical protection of NHIS, most of these workers rely on drugs sourced from unlicensed and ill-trained hawkers (another member of the shadow economy) whenever they feel unwell. Going for the COVID – 19 test is a luxury they can hardly afford (as findings from this study indicated) even when they are promised free access by the government – the fear of losing their daily income which is normally a derivative of their daily ‘hustling’ make such thought repugnant to them.

At the global level, the spread of COVID-19 has resulted in a considerable slowdown of economic activities [3, 4, 5, 23, 24]. Statistics from the International Monetary Fund (2020) projected that the global economy would contract by about 4.9 percent before the end of 2020. The figure is higher than that of the 2008-2009 Global Financial Crisis of between 0.5-1.0 percent [23, 25]. As worrisome as the estimated figure appeared to be, the IMF still believed that it is subject to a downward review if there is a further need for mobility contraction, a steeper decline in productivity, and greater economic uncertainty all occasioned the virulent effects of the pandemic [23, 24]. The World Bank's estimate for Nigeria, however when compared to the global average painted a bleaker picture [26]. Before the outbreak of the pandemic the nation's economy which was just exiting a cataclysmic first recession in some forty years was projected to have a moderate growth of 2.1%. At the outbreak of the pandemic, the World Bank reversed the earlier projection and predicted that the economy will contract by 3.2%, in essence, the economy might likely shrink by 5.3% which is 0.4% lower than the global average [26].

Due to its evolving nature, few studies have assessed the impact of the covid-19 pandemic on the household economy, although there is a consensus that most individuals living within the fringes of the poverty line and those below it may feel the impact more than others [27]. [27] studied the socioeconomic impacts of covid-19 on household consumption and poverty in the San Francisco Bay Area, their study relied on secondary data in the form of census tract data and discovered that the poverty rate among the residents of the case study increased by a staggering 8.8% in just three months (from 17.1 to 25.9 percent). The study further posited that residents who relied on shared mobility and public transit system as means of accessing places of interest bore the heavier brunt of the pandemic.

The research by [27], just like those carried out in different EU cities and London (UK) concluded that there is a distinctive spatial pattern in the distribution of those who bore the most harrowing impact of the pandemic either nationally, regionally or within a city [12, 13, 14, 16, 17]. One central verity that most studies that examined the economic impact of the pandemic have established is that it is more impactful on the livelihoods of those in the lower rungs of the economic ladder. Pieces of evidence from some of the earlier studies on the management of the pandemic also indicated that the spread of the contagion responded positively to the use of behavioral changes and NPI approaches [13, 28] as means of curtailing the spread. Questions, however, are being asked if these measures which strongly advocate restriction or cessation of movement (in some instances) can be sustainable management practices in an economy where a disproportional percentage of the citizens are engaged occupationally in the informal sector and where these citizens also depend largely on shared mobility/public transit system as the main means of transportation.

This present study filled an important gap in the ongoing discourse by employing an empirical analysis to examine primarily sourced data on the effect of the pandemic on mobility decisions and the consequential impact on the economic well-being of informal employees in a developing economy. Findings from contemporary research on the discourse have shown that the deployment of mathematical modeling and empirical philosophical viewpoints in data analyses has brought some inimitable benefits for all stakeholders (research community, government agencies, and the industry) [29, 30, 31]. [30] developed a novel mathematical model that designed a novel sustainable mask Closed-Loop Supply Chain Network (CLSCN). The employment of a multi-objective Mixed-Integer Linear Programming (MILP) was created to address the locational, supply, production, distribution, collection, quarantine, recycling, reuse, and disposal decisions within a multi-period multi-echelon multi-product supply chain. Such applications provide an objective and directional result to the problems associated with the sustainable utilization of face masks as an NPI in the management of the COVID-19 pandemic, and the handling of any pandemic with a similar NPI attribute.

The study also analyzed the perceptions of respondents on how economically and operationally sustainable are the deployment of NPI approaches in the management of the covid-19 pandemic.

Findings from this study are critical given the second wave of the contagion being presently experienced in some globally. [32], while outlining some of the safety strategies public transport operators and vehicle manufacturers are incorporating as part of their 'new normal or Standard Operating Procedure (SOP) argued that it is very debatable if some of these itemized developments (reducing the number of boarding passengers, reconfiguring the internal layout of seats, periodic circulation spaces on buses and trains, installing contactless door sensors, hand sanitizer dispensers and clear screens between seats to provide a physical barrier to airborne aerosols) can be economically sustainable by operators in the long run [32, 33]. Given the foregoing, it is therefore imperative that detailed analyses on how Social Economic Situation (SES) variables of respondents (age, marital status, educational attainment, employment type, and occupational distribution) alongside important factors on how 'secured' (dreadful perception) do they passengers believed the entire public transit system is being carried out in the study area. Similarly, examination of the factors which informed respondents' trip decisions during the period of government-imposed lockdown is also necessary as this will deepen the understanding of the reactionary dispositions of the transiting public towards' issues bothering on public health and transport system. The identification of these two critical gaps led to the formulation of the following hypotheses which are tested in this study:



H1: Passengers' Social Economic Situations (age, marital status, educational attainment, employment type, and occupational type) and dreadful perception of transport facilities are not significant determinants of the usage of the public transit system for trips during the COVID -19 pandemic-induced lockdown.

H2: Respondents' trip decisions during the pandemic are significantly determined by their beliefs in the government-formulated measures against the spread of the pandemic, safety practices deployed in the management of the park, the economic situation of respondents, and their desire for a sustainable urban transport system.

### 3. Methodology

This research utilized a positivist approach. The data used were gotten from a primary source. The research instrument was a structured questionnaire. The sampling technique employed for this study is a combination of multistage and random sampling techniques. The two are used in selecting participants for this study. The targeted populations for the study are passengers which took inter-state trips between Ibadan (Oyo-state capital) and Lagos (Nigeria's commercial capital) during the period when the government-imposed movement restriction was fully /partly in place as a result of the pandemic. There are six (6) main bus parks in Ibadan which operates inter-state bussing system between Ibadan and Lagos under the management of the National Union of Road Transport Workers (NURTW). These 6 parks are sited in Ojoo, Iwo Road, Olomi Academy, Sango, University of Ibadan school gate, and Challenge. Three (3) of these parks were randomly picked for the study; these are those in Ojoo, Iwo Road, and Challenge. The study took place for three (3) months. It commenced in the first week of June and ended in the last week of September 2020.

The first phase of the Federal Government (FG) imposed lockdown due to the incidence of the pandemic began on the 29th of March and phase one ended on the 2nd of June 2020. The study was done when phase two of the lockdown was in operation (Table 1 depicted the timeline of phase two of the lockdown in Nigeria and its features). The choice of inter-city transit passengers between Lagos and Ibadan is borne out of some salient facts. First, the two cities are the biggest in terms of population sizes in the country (they have over 25 million inhabitants). Second, the volume of road traffic density between the two cities (as a reflection of the commercial activities between them) is perhaps one of the heaviest in the SSA region (NBS, 2018). It is therefore believed that findings from such a study can provide an informed insight into the perceptions of most public passengers on the management of the contagion and sustainable transport management in SSA's biggest economy (Figure 1 shows the daily incidences of the contagion between Feb 27 and Oct 10, 2020).

Table 1: Timeline of the Government Imposed Partial Lockdown in Nigeria

Timeline	Date	Features
Commencement of the second phase of the lockdown	2 <sup>nd</sup> of June, 2020 – 29 <sup>th</sup> of June, 2020	*Nationwide curfew from 10 pm -4am. Healthcare workers and journalists are exempted from the curfew. *Banks are to resume normal working hours. *Government offices are to be open between 9 am to 12 pm, from Monday to Friday. *The ban on interstate road transport movement remains in effect except for essential services (food, energy products, manufactured goods and essential services). *All airports remain closed to both domestic and international flights.
First adjustment of the second phase of the lockdown	30 <sup>th</sup> of June-27 <sup>th</sup> of July, 2020	*Safe reopening of schools for graduating class * Ban on interstate travel lifted, buses are allowed to take trips but must only travel with 50% of their carrying capacity.
Full Reopening of the economy, after six months of different phases of lockdowns	15 <sup>th</sup> October 2020	*Safe reopening of schools at all levels *Reopening of all economic activities

Source: Author Analysis, 2022

A selected park had ten days slated for it, each month in the fieldwork program drawn up by the research team: at the end of the exercise each selected park was visited for a month. Available records obtained from the park managers of these parks showed that an estimated 9,900 passengers boarded busses from the parks to the Lagos metropolis in the first three months of the year (January to March 2020). Due to the outbreak of the pandemic and the movement restriction in place that made the busses operate at half full capacities for the periods of the field-work, an estimated population of 4,950 passengers (50% of the passengers' population between January and March) served as the targeted population for the study. Five percent of the targeted population (4,950 passengers) were randomly selected for the study. This translated to 248 passengers being sampled. At each of the three parks visited the odd-numbered busses to load passengers for the trips were chosen on the days and all the passengers inside such busses were sampled, 181(73%) of the 248 randomly distributed questionnaires were retrieved and utilized for the analysis. The breakdown of how the questionnaires were randomly sampled and retrieved for the study is thus:

Table 2: Breakdown of questionnaires' sampling in the selected parks

Parks	Numbers of respondents sampled	Numbers of questionnaire retrieved	Percentage
Ojoo	74	49	66.2
Iwo Road	94	75	79.8
Challenge	80	57	71.3
Total	248	181	72.9

Source: Author's Analysis 2022.

The research instrument is a structured questionnaire with pre-tested items that provided a measurement for the objectives of this study. The questionnaire was sub-divided into four sections: (i) socio-economic characteristics of the respondents (ii) measurement of respondents' dreadful perception concerning transport facilities as a means of the spread of the covid-19 (iii) respondents' beliefs in the capability of the sustainable management against the spread of pandemic by the government (iv) economic situations of the respondents (v) desire for the sustainable urban transport system.

This research protocol got approved by the Ethical Committee of the Redeemer's University (Nigeria). All respondents were informed of the objectives behind the research, and their consent was obtained, effort was also made to ensure strict confidentiality of all information from the respondents as outlined in the approved research protocol. This was done by the use of code rather than respondents' identities in data representation.

The research team had a pre-field exercise to ensure the validity, and reliability of the research instruments. In addition, the Cronbach alpha test was carried out on each of the constructed multi-items instruments to observe their internal reliability and capability to effectively measure the research variables. A Cronbach's alpha lower than 0.60 indicates poor reliability, values between 0.6 and 0.7 are acceptable, and values equal to or higher than 0.70 indicate good scale reliability [34, 35, 36, 37]. The respondents' perceptual beliefs in the sustainability of the measures provided by the government against the spread of the pandemic subscale which contained 9 items have a Cronbach alpha of .89 ( $\alpha=.89$ ).

The subscale that assessed how the park managers implemented the safety practices outlined by the government in the management of the park had 7 items with a Cronbach's alpha of .79 ( $\alpha=.79$ ). The subscale on the role played by the economic situation of respondents on trip decisions had 8 items with a Cronbach alpha of .86 ( $\alpha=.86$ ). The subscale on how Covid-19 influenced the desire for sustainable urban transport system had 7 items with a Cronbach alpha of .75 ( $\alpha=.75$ ).

The last subscale which measured the dreadful perception of transport facilities as a means of the spread of the Covid-19 had 7 items with a Cronbach alpha of .79 ( $\alpha=.79$ ). All the information obtained from the questionnaires was codified into Microsoft Excel (2014) workbook sheet for database management activities. Subsequent statistical analyses were carried out using IBM Statistical Package for Social Sciences (SPSS), version 23.

#### 4. Results

Below is the breakdown of the demographic and inferential analyses from the gathered data.

Table 3: Socioeconomic Attributes of the Respondents

Attributes	Total Number of Respondents	Percentage (%)
<b>Gender</b>	181	100
Male	95 (52.48)	52.48
Female	86 (47.52)	47.52
<b>Age</b>	181	100
21-25	20	11
26-30	23	12.7
30-34	37	20.44
35-39	30	16.57
40-44	33	18.23
45 and above	38	20.99
<b>Marital Status</b>	181	100
Single	47	26.5
Married	102	56.35
Divorced	17	9.40
Widowed	15	8.20
<b>Educational Status</b>		
Primary School Leaving Certificate	2	0.8
Secondary School Leaving Certificate	48	18.11
Ordinary National Diploma	190	(71.70)
Bsc and others	25	9.40
<b>Types of Employment</b>		
Informal	156	86.18
Formal	25	13.82
<b>Occupational Type</b>		
Business owners	83	45.86
Artisans	39	21.54
Technicians	34	18.78
Civil /Public servants	25	13.82
<b>Major means of Mobility</b>		
Personal Vehicle	42	
Shared Mobility (Taxi)	32	
Shared Mobility (Commercial Bus)	107	
<b>Effect of the Pandemic on the Use of Shared Mobility</b>		
Strongly Affected	82	45.30
Affected	75	41.43
Indifferent	10	5.52
Not Affected	14	7.73
<b>Willingness to Comply with Public Transit Covid-19 Prevention Protocol</b>		
Strongly Willing	51	28.18
Willing	78	43.09
Not Willing	30	16.58
Strongly Not Willing	22	12.15

Source: Author's Analysis, 2022

#### 4.1 Inferential Statistics

Table 4: Summary of Multiple Regression Analysis showing the prediction of respondents' socioeconomic status and dreadful perception of public transport facilities on the usage of public transit during lockdown

Predictor	B	T	P	R	R <sup>2</sup>	F	p
Gender	-.04	-.32	.73				
Age	-.4.1	-2.1	.03				
Marital Status	-.08	-0.5	.95	0.58	0.38	7.6	<.05
Educational Attainment	.04	3.3	.01				
Employment Type	.03	.31	.01				
Occupational Distribution	-.04	-2.3	.02				
Dreadful Perception	-.10	-.40	.70				

Dependent Variable: Usage of public transit during lockdown

The result of the multiple regression analysis is depicted in Table 4. The first derived hypothesis stated that: the ‘‘Socio-Economic Situation of respondents (age, marital status, education, employment type, and occupational distribution) and the dreadful perception of the public transit system does not significantly predict the usage of public transit system during lockdown’’ had seven predictors which explained 58% of the variance ( $R^2 = .0.58$ ,  $F(6,175) = 7.6$ ,  $p < .005$ ). It was found that the Socio-Economic Situation of the respondents regarding the public transit system and their dreadful perception of the public transit system significantly predicted its usage in the study area during the period the lockdown rule was in place. The result further indicated that of the seven independent variables (Table 4), 4 of them namely age ( $\beta = -.41$ ,  $t = -2.1$ ;  $p < .05$ ), educational attainment ( $\beta = .40$ ,  $t = 3.3$ ;  $p < .05$ ), employment type ( $\beta = .03$ ,  $t = -.021$ ;  $p < .05$ ) and occupational distribution ( $\beta = -0.35$ ,  $t = -0.23$ ;  $p < .05$ ) significantly predicted the usage of public transit system during the period the lockdown in the study area. On the other hand, two of the SES variables of gender ( $\beta = -0.46$ ,  $t = -0.3$ ;  $p > .05$ ), marital status ( $\beta = -0.8$ ,  $t = -0.5$ ;  $p > .05$ ), and the variable measured the respondents likely dreadful perception of the entire public transit system ( $\beta = -0.10$ ,  $t = -.20$ ;  $p > .05$ ) do not significantly predict the usage of the public transit system during the period the lockdown was in place in the study area (Table 4).

Table 5 detailed the multiple regression analysis of the derived hypothesis which tested that the respondents' trip decisions during the pandemic are significantly determined by their beliefs in the government formulated measures against the spread of the pandemic, safety practices deployed in the management of the park, the economic situation of respondents, and their desire to observe urban transport sustainable practices’’. The result from the analysis ( $R^2 = .0.24$ ,  $F(6,175) = 1.63$ ,  $p > .005$ ) showed that the hypothesis was rejected. In essence, the result which showed that the four predictors explained a paltry 24% of the variance also indicated that the respondents' trip decisions during the period of the lockdown were not significantly determined by the selected variables.

Table 5: multiple regression analysis of the derived hypothesis

Predictor	B	T	P	R	R <sup>2</sup>	F	p
Perception on Govt Measures	.10	1.5	.13				
Mgt. of Public Transit System	.12	.24	.81	.20	.24	1.63	>0.05
Economic Situation	.16	2.0	0.4				
Desire for Sustainable Urban Transport	.01	.12	.10				

Dependent Variable: Determinants of Trip Decision during Lockdown

A more detailed analysis of the result indicated that it was only the ‘economic situation’ variable ( $\beta = .16$ ,  $t = 2.0$ ;  $p < .05$ ) which significantly predicted the respondents' trip decisions during the period of the lockdown. All three remaining variables are not significant predictors of the respondents' trip decisions during the period examined.

## 5. Discussion

An indubitable fact unearthed from this study is that the bulk of those who felt the need and who engaged in inter-state trips during the period the partial lockdown was in place, where workers who are informally employed (86.19% of the randomly selected respondents are all engaged informally at the time of the study). The figure is much higher than the 56.25% that the Nigeria Bureau of Statistics declared as the national average [10]. A major inference that can be drawn from this is that more informal employees who are not on salaried income felt the greater urge to go out and engaged in economic activities – regardless of the risk of the contagion. Another reality that this research brought to light is that most of those engaged in the informal sector in Nigeria are educated over 97% of the respondents had more than six years of primary or basic education, the import of these two highlighted facts (employment structure and educational distribution) on the management of the contagion cannot be underestimated.

Research findings have shown that educational attainment enjoys a causality with determinants of healthiness in a given population by predicting key indices such as health behaviors, risky contexts, and preventative service use [38, 39, 40]. There seems to be a substantial element of such correlation in this study, as the bulk of the respondents 129 (94.09%) affirmed their willingness to adhere to the public health protocol guiding the use of the public transit system due to the incidence of the contagion. Shreds of evidence from a Japanese study on the development of a sustainable approach to the management of the contagion indicated that the literacy level of the general population helped in the assimilation of the “Three Cs” (3Cs) concept which was used to tactically denote high-risk places and situations to be avoided: 1) Closed spaces with poor ventilation; 2) Crowded spaces with a lot of people; and 3) Close contact with other persons [41, 2]. Moreover, the result of the first hypothesis showed that a substantial element of SES variables measured in the study (including educational attainment) constituted significant predictors of the use of the public transit system during the period studied. Four (4) of them, namely the gender ( $\beta = -.41$ ,  $t = -2.1$ ;  $p < .05$ ), educational attainment ( $\beta = .40$ ,  $t = 3.3$ ;  $p < .05$ ), employment type ( $\beta = .03$ ,  $t = -.021$ ;  $p < .05$ ) and occupational distribution ( $\beta = -0.35$ ,  $t = -0.23$ ;  $p < .05$ ) significantly predicted the usage of public transit system during the period the lockdown in the study area.

Another inference that can be drawn from this result is perhaps the possibility of the existence of a causal relationship between employment type, the economic well-being of citizens, and promptness in obeying emergency public health guidelines that either limit or restrict movement. Public health law theorists [42] provided an incisive understanding of the likelihood of the existence of misalignments between legislation, regulation, and the reasonable limits that governments may place on personal freedom to promote the health of the population. Generally, citizens tend to be more responsive and responsible to either a subsisting or a new emergency rule on public health when they believe that the government will be equally responsive to their needs as occasioned by the emergent public health situation. As earlier established, findings from this study showed that the bulk of the randomly sampled respondents are informally employed (86.17%) while the result from regression analysis also indicated that employment type ( $\beta = .03$ ,  $t = -.021$ ;  $p < .05$ ) and occupational distribution ( $\beta = -0.35$ ,  $t = -0.23$ ;  $p < .05$ ) (amongst other SES variables) significantly determined the usage of public transit system during the period studied (when there was a partial lifting of the lockdown). Based on the foregoing it is, therefore, safe to surmise that most of the respondents who refused to implicitly obey the ‘stay at home order of the government did so for personal economic reasons: workers who are not assured of the regular payment of salaries and those who are not on salaried income obviously, had difficulty obeying stipulated Covid-19 protocols.

The second hypothesis which x-rayed the determinants of trip decisions among the respondents during the period of the partial lockdown equally indicated that their economic situation is the sole significant predictor ( $\beta = .16$ ,  $t = 2.0$ ;  $p < .05$ ) among the other considered variables. It is particularly worrisome that the respondents' faith in the government-formulated measures to prevent the spread of the contagion ( $\beta = .10$ ,  $t = 1.5$ ;  $p > .05$ ), their belief in the implementation of sustainable Covid-19 safety protocol by the operators and managers of the public transit system ( $\beta = .12$ ,  $t = 0.24$ ;  $p > .05$ ), and their desires to positively contribute to the achievement of sustainable urban transit system ( $\beta = .01$ ,  $t = 0.12$ ;  $p > .05$ ) are not significant determinants of their trip decisions during the studied period. On a positive note is

the fact that respondents' "dreadful perception" of the public transit system was not a significant determining factor ( $\beta = -0.10$ ,  $t = -.20$ ;  $p > .05$ ) behind the usage of the public transit system during the studied period. The implication of this salient fact is unquantifiable for stakeholders desirous of achieving an impressionable level of societal sustainable transport development in the study area. A major concern of experts in the field of sustainable transport is that the outbreak of the contagion has quickly redefined the gains made in the last two decades – when the drive for sustainable transportation witnessed massive traction among the global community [43, 44, 45].

In recent times, it has been noticed that urban mass transit system, cycling and walking share of the public transit system has been in the ascendency when compared with the use of personal automobiles as evinced through verifiable data [43, 44, 45]. Concerted efforts must therefore be made by all stakeholders to prevent the public transit system from being denoted as an 'epicenter' of the spread of the contagion, such perceptions will do incalculable damage to the goal of achieving the much-desired societal sustainable transport development. This could be done by conducting scientific research on the spatiotemporal pattern of the incidences of contagion across key interactive locations within the urban space. Results gotten from such research will prevent simplistic assumptions (mostly anecdotally obtained) that public transit systems are epicenters of the contagion. It is surprising that even though most of the sampled respondents (84.75%) affirmed that the outbreak of the contagion negatively affected their decisions to utilize the public transport system; it remained their modal choice for trips even at the risk of being infected by the contagion. This result further reinforces the belief of experts that the economic situation of a populace should be a salient consideration in the quest for a rational selection of a sustainable urban transportation option by politicians and policymakers [46, 47]. Sustainable urban transport modal options centered on the promotion of non-motorized means of mobility (biking and walking) as credible alternatives to motorized transport systems are no popular choices in the study area.

## 6. Conclusion and Areas of Further Research

Conclusively, some salient lessons could be learned through results garnered from this research. One such is the lucidity of the fact that some SES variables (educational attainment, gender, employment type, and occupational distribution) are significant determinants of respondents' usage of the public transit system during the studied period. Another reality brought to the fore through this research is the fact that implicit compliance with government-formulated measures aimed at restricting movement and maintaining social distancing amid the pandemic is not guaranteed. Unlike the situation available in more prosperous Western nations where governing authorities rolled out measures that discouraged the use of public transportation as means of curtailing the contagion [48, 49, 50, 51], such approaches may not readily work in SSA. Conversely, the curtailment of the contagion in the region might go beyond the holistic 'importation of any model evolved in other places' without incorporating salient socioeconomic situations as it concerns the employment nature prevalent in the region and the income levels of the bulk of the citizens in the region.

Findings from this research also indicated that respondents are highly knowledgeable about the contagion, ordinarily; this is a positive development as it is reflected in the willingness among a huge proportion of the respondents to personally observe rules (wearing face masks, maintaining social distance in transit and the use of hand sanitizers) against the spread of the contagion. However, the expression of distrust between the governed and the government reflective in their lack of faith in the government-formulated measures or the capability of the public transit managers to successfully implement sustainable measures to curtail the contagion is disturbing. Available statistics have clearly shown that the ownership holdings of the public transit system in SSA are largely concentrated in the hands of private individuals/investors who owned most of the automobiles conveying passengers and goods in the region [21].

Based on the foregoing, concerted efforts must be made by the government and these private investors to systemically improve the quality of the public transit system in the region to reposition the faith of the transiting public in it. There is no doubt that the incidence of the contagion revealed the parlous state of the public transit system in Nigeria and the disheartening state of the country's public transit system

on a timely response to health emergencies, which could be a more regular occurrence given the increasing fragility of the global public health system in the future. It is safe to suggest that the developers of national sustainable transportation policies in developing countries must carefully consider the economic situations of the populace in the designing of their programs. As could be gleaned from findings in this study, respondents' desires to positively contribute to the achievement of sustainable urban transit was not a significant determinant of trip decisions during the studied period most of the respondents presently utilize public mass transit mainly because they have no personal means of mobility (over 70% affirmed this).

An inference that could be drawn from the result is the likelihood of causality between the economic situations of respondents and their willingness to utilize the public mass transit system. Studies which investigate the perceptual beliefs of the troika of the users of the public transit system, private investors in the public transit system, and government policymakers on the implementation of a sustainable urban transportation plan in the study area are therefore needful.

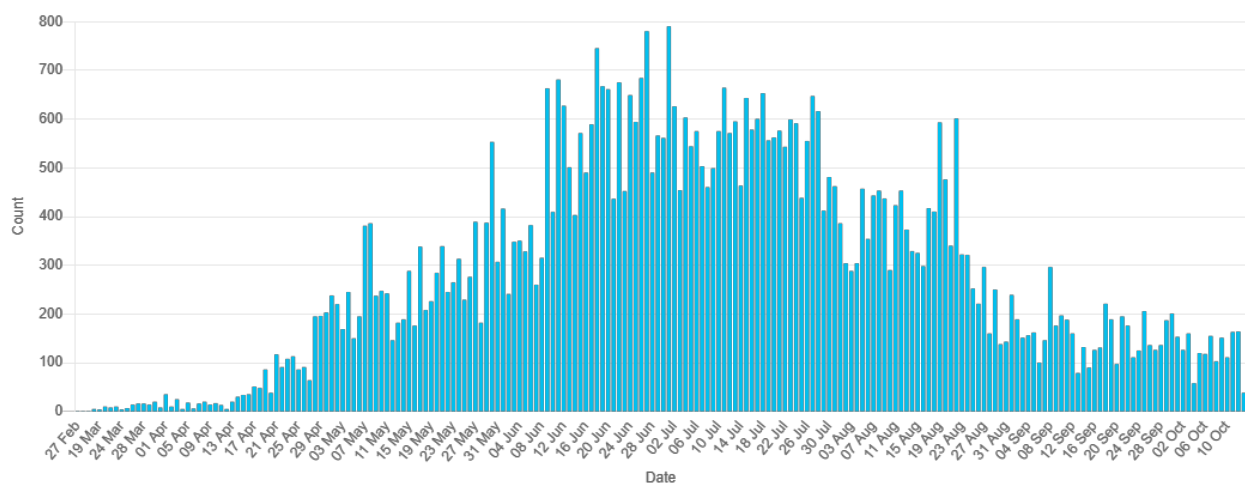

Figure 1: Graphic representation of daily incidences of covid-19 for the period the study covered (Feb 27-10 Oct, 2020)

### Contribution of Researchers

All researchers have contributed equally to writing this paper.

### Conflicts of Interest

The authors declare no conflict of interest.

### References

- [1] Nigeria Centre for Disease Control.: Covid-19 Outbreak in Nigeria. Situation Report. Available online: (2020)<https://ncdc.gov.ng/news/227/first-case-of-corona-virus-disease-confirmed- in-nigeria> Accessed on 15<sup>th</sup> of May, 2020. 2020
- [2] World Health Organization.: United Nation Educational Scientific and Cultural Organization. Considerations for school-related public health measures in the context of COVID-19. Annex to Considerations in adjusting public health and social measures in the context of Covid-19. Available online: <https://apps.who.int/iris/handle/2020>
- [3] M. Nicola Z. Alsafi C. Sohrabi, et al. "The socio-economic implications of the coronavirus pandemic (COVID-19): A review". International Journal of Surgery (London, England). Jun, 78:185-193. DOI: 10.1016/j.ijsu.2020.04.018. 2020
- [4] PricewaterhouseCoopers.: Macroeconomic impact of COVID-19 in China and policy suggestions. <https://www.pwccn.com/en/covid-19/macro-economic-impact-covid19-policy-suggestions.pdf>. Accessed 4th June, 2020. 2020
- [5] B. Dhar, "Impact of COVID-19 on Chinese Economy". Economic Affairs. 9. 23-26 2020

- [6] T. Packard, J. Koettl, and C. Montenegro, In from the Shadow Integrating Europe's Informal Labor. International Bank for Reconstruction and Development / The World Bank. DOI: 10.1596/978-0-8213-9550-9. 2012
- [7] M. Arbex, R. Freguglia, and C. Flavia, "Informal economy and spatial mobility: Are informal workers economic refugees". *Journal of Economic Studies*. 40. 10.1108/JES-08-2011-0104.201. 2013
- [8] V. Almenar, J. Sánchez, and J. Sapena, "Measuring the shadow economy and its drivers: the case of peripheral EMU countries". *Economic Research- Ekonomska Istraživanja* 33:1, 2904-2918, DOI: 10.1080/1331677X.2019.1706601. 2020
- [9] Carsten ten Brink: "More than 60 per cent of the world's employed population are in the informal economy". ILO Home. 30<sup>th</sup> April. [https://www.ilo.org/global/about-the-ilo/newsroom/news/WCMS\\_627189/lang--en/index.htm](https://www.ilo.org/global/about-the-ilo/newsroom/news/WCMS_627189/lang--en/index.htm) , 2018
- [10] Nigeria Bureau of Statistics.: [https://nigerianstat.gov.ng/elibrary?queries\[search\]](https://nigerianstat.gov.ng/elibrary?queries[search]). Accessed 6<sup>th</sup> June 2020. 2020
- [11] P. Aytyon, S. Murray and J. Hampton, "Terrorism, dread risk and bicycle accidents". *Judgment and Decision Making*, 14, 3<sub>pg</sub>. 280-287. 2019
- [12] International Energy Agency: Changes in transport behaviour during the Covid-19 crisis, IEA, Paris. <https://www.iea.org/articles/changes-in-transport-behaviour-during-the-covid-19-crisis> (assessed 4<sup>th</sup> June, 2020). 2020
- [13] L. Budd, and S. Ison, "Responsible Transport: A post-COVID agenda for transport policy and practice". *TRIP*. 6. Pg 1-4. DOI: <http://dx.doi.org/10.1016/j.trip.2020.100151> 2590-1982, 2020
- [14] G. Bonaccorsi, F. Pierri, M. Cinelli, A. Flori, A. Galeazzi, F. Porceli, A. Schmidt, C. Valenise A. Scala, W. Quattrociochi and F. Pammolli, "Economic and social consequences of human mobility restrictions under COVID-19". *PNAS*. <doi.org/10.1073/pnas.2007658117>. 2020
- [15] UITP b.: Public Transport after COVID-19 current and future challenges in 5 major cities. (2020) <https://www.uitp.org/news/public-transport-after-covid-19-current-and-future-challenges-in-5-major-cities/> (assessed 4<sup>th</sup> May, 2020). 2020
- [16] D. Loske, "The impact of COVID-19 on transport volume and freight capacity dynamics: An empirical analysis in German food retail logistics". *TRIP*, 6, 1-6 <http://dx.doi.org/10.1016/j.trip.2020.100165>. 2020
- [17] A Aloï, B Alonso, J Benavente, R. Cordera, E. Echániz, F. González, C.L. Ladisa, et al. "Effects of the COVID-19 lockdown on urban mobility: empirical evidence from the City of Santander (Spain)". *Sustainability* 12 (9), 3870. <https://doi.org/10.3390/su12093870>. 2020
- [18] F. Schneider, and C.C. Williams, *The shadow economy*. "The Institute of Economic Affairs". 2 Lord North Street Westminster London sw1p 3lb in association with Profile Books Ltd. 2013
- [19] A. Sinha, and R. Kabur, "Informality: Concepts, Facts and Models Introduction to a Special Issue of Margin"— *The Journal of Applied Economic Research* 6, pp.91-102. 2012.
- [20] D. Brown, and G. McGrahanan, "The urban informal economy, local inclusion and achieving a global green transformation. *Habitat International*, 53, pg 97-105. <https://doi.org/10.1016/j.habitatint.2015.11.002> 2015
- [21] A. Kiaga, F. Lapeyre, and P. Marcadent, The impact of the Covid-19 on the informal economy in Africa and the related policy responses 1. *International Labor Organization*. 14<sup>th</sup> April 2020. Available online: [www.ilo.org/wcms/741864](http://www.ilo.org/wcms/741864) Accessed 18<sup>th</sup> of May, 2020
- [22] F. Schneider, "Shadow economies around the world: What do we really know" *European Journal of Political Economy* 21:3 : 598–642. 2005
- [23] A. Brodeur, A. Gray, A. Islam, S.J. and Bhuiyan, "A literature review of the economics of COVID- 19". Discussion Paper Series, Institute of Labor Economics. Initiated by Deutsche Post Foundation. [www.iza.org](http://www.iza.org). (accessed 4<sup>th</sup> November, 2020), 2020
- [24] N. Donthu, and A. Gustafsson, Effects of COVID-19 on business and research. *Journal of Business Research*. 117. <https://doi.org/10.1016/j.jbusres.2020.06.008>. 2020
- [25] C. Devonshire-Ellis, A. Livermore, R. Kapur, M. Kotova, P. Varejao, and D. Shira, D, The current social and economic impact of COVID-19 upon The BRICS nations. April 13, (2020). <https://www.silkroadbriefing.com/news/2020/04/12/current-social-economic-impact-covid-19-upon-brics-nations/> 2020
- [26] S. Chaudhuri, and M. Hernandez, "Nigeria's Economy Faces Worst Recession in Four Decades, says New World Bank Report", <https://www.worldbank.org/en/news/pressrelease/2020/06/25/nigerias-economy-faces-worst-recession-in-four-decades-says-new-world-bank-report>. (Accessed 22<sup>nd</sup> of May, 2020), 2020
- [27] A. Martin, M. Markhvida, S. Hallegatte, B. Walsh, "Socio-Economic Impacts of COVID-19 on Household Consumption and Poverty". *EconDisCliCha*. 4, 453–479 <https://doi.org/10.1007/s41885-020-00070-3>. 2020
- [28] T. Edwards, Coronavirus: Will London embrace walking and cycling? 4<sup>th</sup>May, 2020 <https://www.bbc.co.uk/news/uk-england-london-52532893> (accessed 20 September 2020), 2020



- [29] F. Goodarzian, P. Ghasemi, A. Gunasekaren, et al. "A sustainable-resilience healthcare network for handling COVID-19 pandemic". *Ann Oper Res* 312, 761–825 <https://doi.org/10.1007/s10479-021-04238-2>. 2022
- [30] E. Tirkolaei, A. Goli, P. Ghasemi, and F. Goodarzian, "Designing a sustainable closed-loop supply chain network of face masks during the COVID-19 pandemic: Pareto-based algorithms", *Journal of Cleaner Production* 333, <https://doi.org/10.1016/j.jclepro.2021.130056>. 2022
- [31] P. Ghasemi, F. Goodarzian, A. Gunasekaran, and A. Abraham, (Accepted/In press). "A bi-level mathematical model for logistic management considering the evolutionary game with environmental feedbacks". *International Journal of Logistics Management*. <https://doi.org/10.1108/IJLM-04-2021-0199>. 2022
- [32] A. Paton, "Fairness, ethnicity, and COVID-19 ethics". *Bioethical Inquiry*, 17, 595-600. <https://doi.org/10.1007/s11673-020-09999-2>. 2020
- [33] Transformative Urban Mobility: The covid 19 outbreak and implications to public transport some observations. <https://www.transformative-mobility.org/news/the-covid-19-outbreak-and-implications-to-public-transport-some-observations> (assessed 10th July, 2020). 2020
- [34] G.A. Churchillill GA, "A paradigm for developing better measures of marketing constructs". *J Mark Res* 16:64–73. 1979
- [35] D. Simchi-Levi, P. Kaminsky E. Simchi-Levi, *Designing and Managing the Supply Chain: Concepts, Strategies and Case Studies*, "McGraw-Hill", New-York. 2003
- [36] H. Quesada, R. Gazo, S. Sanchez, *Critical factors affecting supply chain management: a case study*. "In Groznik A (Ed.): *The US Pallet Industry, Pathways to Supply Chain*". Excellence, ISBN: 978–953–51- 0367-7, InTech. 2012
- [37] A.P. Ajayi, "Uber: examination of socio-economic situation of its clientele and security components in Lagos", *Journal of Transportation Security*, 13, 1-17 <https://doi.org/10.1007/s12198-020-00216-0>. 2020
- [38] E. Zimmerman, and S. Woolf, *Understanding the relationship between education and health*. Discussion Paper, Institute of Medicine, Washington, DC. Available at: <http://nam.edu/wp-content/uploads/2015/06/understandingtherelationship>. (Accessed 2<sup>nd</sup> June, 2020). 2014
- [39] R.A. Hahn, B.I. & Truman, "Education Improves Public Health and Promotes Health Equity", *International Journal of Health Services: Planning, Administration, Evaluation*, 45(4), 657–678. <https://doi.org/10.1177/002073141558598>. 2015
- [40] A. P. Ajayi and S.P. Mazinyo, "Socio-economic situation and substance use disorder influences on safety practices among truckers". *The Open Transportation Journal* 14:78–85. <https://doi.org/10.2174/1874447802014010078>. 2020
- [41] H. Oshitani, and Experts Members of The National COVID-19 Cluster Taskforce at Ministry of Health, Labour and Welfare, Japan.: "Cluster-based approach to Coronavirus Disease 2019 (COVID-19) response in Japan-February-April 2020". *Jpn. J. Infect.Dis.* doi:10.7883/yoken.JJID.2020.363. 2020
- [42] P. Kowal, and T. Bubela, *Legal Issues in Public Health*, Editor(s): Stella R. Quah, *International Encyclopedia of Public Health (Second Edition)*, Academic Press, Pages 384-390. <https://doi.org/10.1016/B978-0-12-803678-5.00250-2>. 2017
- [43] A. Arturo, "With COVID-19, the case for sustainable transport is stronger than ever" <https://blogs.worldbank.org/transport/covid-19-case-sustainable-transport-stronger-ever> 2020
- [44] C. Musselwhite, E. Avineri, and S. Yusak, "The Coronavirus Disease COVID-19 and implications for transport and health". *Journal of Transport & Health*, 16 <https://doi.org/10.1016/j.jth.2020.100853>. 2020
- [45] B. Welle, and S. Avelleda, "Safer More Sustainable Transport in a Post-COVID-19 World, <https://thecityfix.com/blog/coronavirus-public-transport-stimulus-packages-ben-welle-sergioavelleda/> (assessed 20<sup>th</sup> December, 2020). 2020
- [46] D. Pojani, and D Stead, "Policy design for sustainable urban transport in the global south". *Policy design and practice*. 1:2, 90-102. DOI:10.1080/25741292.2018.1454291. 2018
- [47] Cigu, E.; Agheorghiesei, D.T.; Gavriluță, A.F.; Toader, E. *Transport Infrastructure Development, Public Performance and Long-Run Economic Growth: A Case Study for the Eu-28 Countries*. *Sustainability* 11, 67. 2019
- [48] Department for Transport.: *Coronavirus (COVID-19): safer travel guidance for passengers*. Department for Transport, United Kingdom. Last updated July 25, 2020. <https://www.gov.uk/guidance/coronavirus-covid-19-safer-travel-guidance-for-passengers>. (Accessed 31<sup>st</sup> August, 2020). 2020
- [49] International Association of Public Transport a., *Management of COVID-19 guidelines for public transport operators* [https://cms.uitp.org/wp/wp-content/uploads/2020/06/Corona\\_Virus\\_EN.pdf](https://cms.uitp.org/wp/wp-content/uploads/2020/06/Corona_Virus_EN.pdf). (Assessed 16<sup>th</sup> September, 2020). 2020
- [50] A. Tirachini, and O. Cats, "COVID-19 and Public Transportation: Current Assessment, Prospects, and Research Needs". *Journal of Public Transportation* Vol. 22 No. 1 pp. 1-21.2020
- [51] K. Arnaud, "Urban transport and COVID-19 challenges and prospects in low- and middle-income countries". *Cities and Health*.DOI: 10.1080/23748834.2020.1791410. 2020



# Optimum Power Flow by using Interior Point Optimization Method

Yunus YALMAN<sup>1</sup>, Özgür ÇELİK<sup>2</sup>, Adnan TAN<sup>3</sup>, Kamil Çağatay BAYINDIR<sup>1</sup>

<sup>1</sup>Ankara Yıldırım Beyazıt University, Ankara, Turkey; ORCID: 0000-0003-1032-9814; [0000-0002-9413-5162](https://orcid.org/0000-0002-9413-5162)

<sup>2</sup>Adana Alparslan Türkeş Science and Technology University, Adana, Turkey; ORCID: [0000-0002-7683-2415](https://orcid.org/0000-0002-7683-2415)

<sup>3</sup>Çukurova University, Adana, Turkey; ORCID: [0000-0002-5227-2556](https://orcid.org/0000-0002-5227-2556)

\* Corresponding author: [yyalman@ybu.edu.tr](mailto:yyalman@ybu.edu.tr)

Received: 21 December 2022; Accepted: 29 December 2022

**Reference/Atf:** Y. Yalman, Ö. Çelik, A. Tan, K. Ç. Bayındır, “Optimum Power Flow by Using Interior Point Optimization Method”, Researcher, vol. 02, no. 02, pp. 131-138, Dec. 2022, doi: 10.55185/researcher.1222156

## Abstract



The electric power industry is mainly responsible to ensure the high-quality, reliable, and economical operation of power systems by defining the limits and constraints of power system equipment. This paper uses the interior-point method to solve the nonlinear OPF problem. This method adjusts optimum values of OPF control variables, including the generator's active and reactive power output, with the objective function of minimizing total system losses. The interior-point method has been analyzed on a standard IEEE-14 bus test system using optimum power flow/unit commitment tools of DIgSILENT/Powerfactory. The analyses are conducted for alternating current (AC) power flow analysis and optimum power flow analysis, which represent Case 1 and Case 2, respectively. The results indicate that the total losses of the power system are reduced from 13.39 MW to 2.31 MW with the proposed algorithm.

**Keywords:** optimum power flow, optimization methods, interior point method, power system network

## 1. Introduction

Power system engineers concentrate on OPF which provides an efficient solution for power system planning and operation. The main objective of OPF is to minimize operational costs and power system losses with reliable and uninterrupted electricity [1]. To maintain reliable and uninterrupted electricity, OPF should satisfy all equality constraints: the bus real and reactive power balance, the set points of generator voltage, the megawatt interchange of area, and inequality constraints. The constraints consist of the flow limits of the transmission line/transformer, active and reactive power limits of the generator, and the bus voltage magnitudes [2].

In this paper, the OPF problem is solved using the interior point method in optimum power flow/ unit commitment tools of DIgSILENT/Powerfactory to minimize total system losses. The proposed method is implemented in the IEEE-14 bus. To illustrate the performance of the optimization algorithm, the obtained results are compared with the AC power flow case. The main contributions of the present research are explained as follows:

- The interior point optimization method for the OPF problem is applied to minimize power system losses in DIgSILENT/Powerfactory
- The application to the standard IEEE test system is performed. Thus, the capability of the proposed method is acquired.
- Technical and economic objective functions for the tested power system are explained.

The paper is organized as follows: In section two, the methodology of OPF is presented. In section three, the OPF study of the IEEE-14 bus system is realized using interior-point and AC optimization methods. In section four, the results are compared for the IEEE-14 bus system. Finally, a brief conclusion is presented in section five.

## 2. Optimum Power Flow

In the literature, gradient-based method [3], nonlinear and quadratic programming [4], linear programming (LP) [5] and interior-point methods (IPM) [5]–[7], Genetic algorithm (GA) [1]–[8], glowworm swarm optimization [9], sine cosine algorithm [8]–[9], artificial bee colony algorithm [12]–[15], adaptive charged system search algorithm [16], Particle swarm optimization (PSO) [17]–[20], are used to solve OPF problem. Conventional methods such as the gradient-based method or LP are susceptible to points of starting and usually converge local optimum. LP methods are fast but have a disadvantage due to utilizing only linear objective functions. The disadvantage of NLP is that it has a complex algorithm. Methods based on modern optimization techniques such as GA, PSO, artificial be colony algorithm, and sine/cosine algorithm produce better results thanks to the robust and parallel algorithm for the OPF problem.

The OPF techniques are realized to determine the optimum operating state of the power system satisfying all operational and physical constraints. OPF is defined as complex nonlinear mathematical programming. The OPF problem involves some controllable variables to get desired operating conditions [20]. The main objective of OPF is to ensure specific objectives, such as minimizing losses and generator costs by optimizing control variables. The OPF problem can be mathematically stated as follows:

$$\text{minimize: } f(x, u) \quad (1)$$

$$\text{subject to: } g(x, u) = 0 \quad (2)$$

$$h(x, u) \leq 0 \quad (3)$$

where  $f(x, u)$  is the total losses function of the power system which needs to be optimized,  $g(x, u) = 0$  is the equality constraint presenting the load flow equation,  $h(x, u) \leq 0$  is the inequality constraint presenting state variable limit. The "u" vector comprises of independent variables or control variables, and the "x" vector consists of dependent variables or state variables. State variables are shown in (4).

$$[x]^T = [V_{L1} \dots V_{LN}, P_{G1}, S_{L1} \dots S_{LM}] \quad (4)$$

$V_{L1}$ : bus voltage

$P_{G1}$ : slack bus active power

$S_L$ : transmission line loading

Control variables are shown in (5)

$$[x]^T = [P_{G1} \dots P_{GZ}, Q_{G1} \dots Q_{GZ}] \quad (5)$$

$P_G$ : generator active power

$Q_G$ : generator reactive power

Z: number of total generators

N: number of buses

M: number of transmission line

P: number of transformers

### 2.1 Equality Constraint:

Active and reactive power balance usually describes as the equality constraints at each load bus as shown in (6) and (7).

$$\sum P_s = 0 \quad (6)$$

$$\sum Q_s = 0 \quad (7)$$

where "s" is net power injection,  $P_s$  and  $Q_s$  describe net active and reactive power injection at sth bus

## 2.2 Inequality Constraint:

In the OPF, inequality constraints express the upper and lower limit of all variables: generator active and reactive power, bus voltage, transformer tap ratings, and transmission line flow. These constraints are given in from (7) to (12)

$$P_{Gkmin} \leq P_{Gk} \leq P_{Gkmax} \quad k=1 \cdots Z \quad (8)$$

$$Q_{Gkmin} \leq Q_{Gk} \leq Q_{Gkmax} \quad k=: 1 \cdots Z \quad (9)$$

$$V_{kmin} \leq V_k \leq V_{kmax} \quad k=1 \cdots N \quad (10)$$

$$T_{tmin} \leq T_t \leq T_{tmax} \quad t=1 \cdots P \quad (11)$$

$$|\phi_{ij}| \leq \phi_{ijmax} \quad (12)$$

$$|\phi_{ji}| \leq \phi_{ijmax} \quad (13)$$

$P_{Gkmin}$ : minimum active power limit of the kth generator

$Q_{Gkmin}$ : minimum reactive power limit of the kth generator

$P_{Gkmax}$ : maximum active power limit of the kth generator

$Q_{Gkmax}$ : maximum reactive power limit of the kth generator

$V_{kmin}$ : minimum voltage level limit of kth bus

$V_{kmax}$ : maximum voltage level limit of kth bus

$\phi_{ijmax}$ : maximum flow limit transmission line

$T_{kmin}$ : minimum tap ratio limit of the kth transformer

$T_{kmax}$ : maximum tap ratio limit of the kth transformer

## 2.3 Interior Point Method

The basic principle of the IPM is the implementation of a logarithmic barrier function that enables the incorporation of inequality constraints in the objective function. In that way, inequality constraints are indirectly considered. The objective function is updated with a logarithmic function. The barrier function is as follows:

$$f(x,u,z) = f(x,u,z) - z \sum_{k=1}^{n_h} \ln(-h_k(z)) \quad (14)$$

Where  $z > 0$  is the parameter of the barrier. The logarithmic function provides that  $h(z) < 0$ . For effective minimization of the objective function,  $z$  is decreased monotonically to zero. The IPM consists of a five-step process which are initial guess, computing variable directions, updating variables reducing the barrier parameter, and convergence test[21].

## 3. Optimum power flow study

OPF problem is solved using the interior point method. The results were obtained through IEEE 14 bus test system in DIgSILENT/Powerfactory.

The main parameter of the IEEE 14 bus test system is given in Table I. In the IEEE 14 bus test system, transmission line impedance data are presented as per unit value. It is required that these values must convert the real value to the model transmission line in DIgSILENT/Powerfactory. So these data are converted as real impedance values by taking 100 MVA base power and related bus voltage and are given in Table 2a and Table 2b.

Table 1: Parameters of IEEE-14 bus test system

Bus	Bus Voltage (pu)	The angle of bus voltage	Active power of load (MW)	Reactive power of load(MVAR)	Active power of generator(MW)	Reactive power of generator(MVAR)	Shunt Capacitance(pu)
1	1.060	0.0	0.0	0.0	232.4	-16.9	0.0
2	1.045	-4.98	21.7	12.7	40.0	42.4	0.0
3	1.010	-12.72	94.2	19.0	0.0	23.4	0.0
4	1.019	-10.33	48.8	-3.9	0.0	0.0	0.0
5	1.02	-8.78	7.6	1.6	0.0	0.0	0.0
6	1.070	-14.22	11.2	7.5	0.0	12.2	0.0
7	1.062	-13.37	0	0	0.0	0.0	0.0
8	1.090	-13.36	0	0	0.0	17.4	0.0
9	1.056	-14.94	29.5	16.6	0.0	0.0	0.19
10	1.051	-15.10	9	5.8	0.0	0.0	0.0
11	1.057	-14.79	3.5	1.8	0.0	0.0	0.0
12	1.055	-15.07	6.1	1.6	0.0	0.0	0.0
13	1.050	-15.16	13.5	5.8	0.0	0.0	0.0
14	1.036	-16.04	14.9	5	0.0	0.0	0.0

Table 2a: The impedance value of the transmission line and transformer

Line from Bus – to Bus	Resistance $\Omega$	Reactance $\Omega$	Susceptance $\mu S$
1-2	3.69	11.268	277.253
1-5	10.289	42.476	258.349
2-3	8.949	37.701	229.994
2-4	11.066	33.578	178.534
2-5	10.846	33.114	181.685
3-4	12.761	32.571	67.213
4-5	2.542	8.019	0
6-11	1.13	2.367	0
6-12	1.463	3.045	0
6-13	0.787	1.551	0
9-10	0.379	1.006	0
9-14	1.513	3.218	0
10-11	0.977	2.286	0
12-13	2.63	2.379	0
13-14	2.0345	4.142	0

Table 2b: The impedance value of the transmission line and transformer

Transformer from bus to bus	Resistance $\Omega$	Reactance (pu)	Tap setting value (pu)
4-7	0	0.20915	0.978
4-9	0	0.55618	0.969
5-6	0	0.25202	0.932
7-8	0	0.17615	0
7-9	0	0.11001	0

Case-1: The IEEE 14 bus test system, established in DIgSILENT/Powerfactory, is shown in Figure. 1. The test system consists of 5 thermal generators, 1 shunt capacitor, and 11 loads. The total load is 259 MW and 73.5 MVAR. In that case study, the AC power flow analysis is carried out. The Newton-Raphson method (power equation) is used as its nonlinear equation solver for AC power flow [22].

Case-2: In that case study, the interior point optimization method is used as its nonlinear equation solver in the optimum power flow/ unit commitment tool of the power factory for the OPF study using the IEEE 14 bus test, which is simulated in Case-1. While control variables of the interior point method are active and reactive power dispatch of the generator, constraints are active and reactive power limits of the generator, branch flow limits, and bus voltage limits.

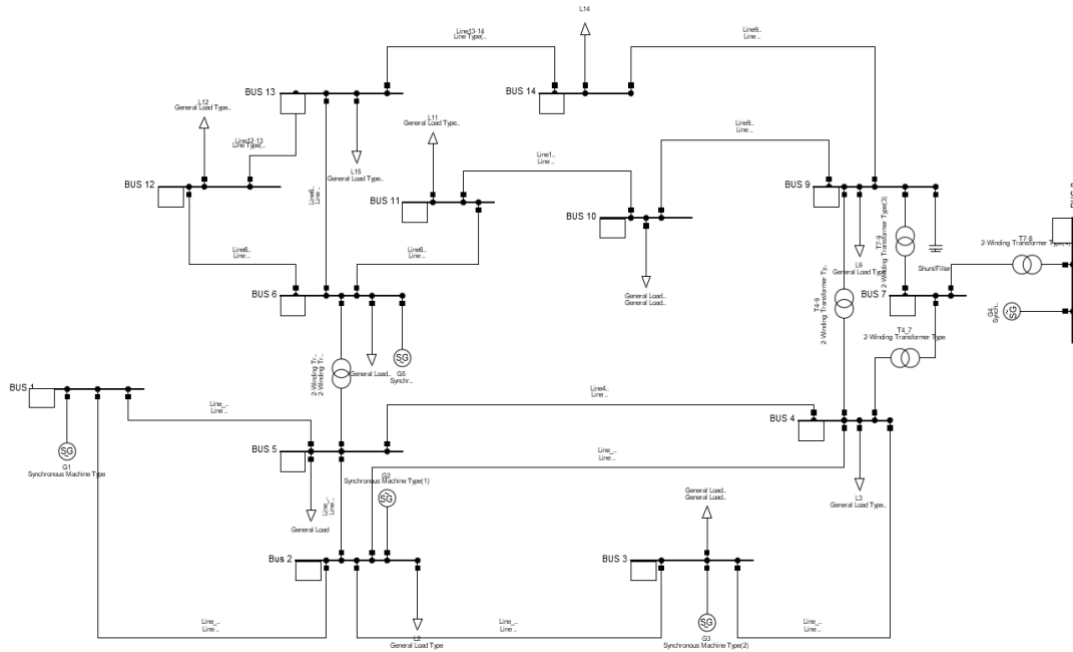

Figure 1: IEEE 14 bus test system in DigSILENT

#### 4. Result and discussion

The voltage value of buses for Case-1 and Case-2 are given in Table III. According to the optimum power flow case, the nominal voltage values of buses for Bus 5-14 get closer rated bus voltage. The voltage value of Bus-8 is 1.09 pu in case of AC load flow (case-1) which is close upper limit voltage value (1.1 pu). When the OPF is applied to the tested power system, the voltage level of Bus-8 is 1.01 pu. Hence, the power system can be operated more reliably.

Table 3: Bus voltages values

Bus	Case-1		Case-2	
	Bus voltage (pu)	Angle of bus voltage	Bus voltage (pu)	Angle of bus voltage
1	1.060	0.0	1.06	0.0
2	1.045	-4.98	1.05	-0.13
3	1.010	-12.72	1.03	-2.35
4	1.019	-10.33	1.02	-2.81
5	1.02	-8.78	1.02	-2.49
6	1.070	-14.22	1.03	-6.53
7	1.062	-13.37	1.02	-2.16
8	1.090	-13.36	1.01	3.19
9	1.056	-14.94	1.03	-5.10
10	1.051	-15.10	1.02	-5.66
11	1.057	-14.79	1.02	-6.62
12	1.055	-15.07	1.02	-7.29
13	1.050	-15.16	1.01	-7.22
14	1.036	-16.04	1.0	-7.09

The loading level of the transformer is given in Table IV. The transformer loading level depends on produced active power of generators. As the produced active power of generators changed, the transformer loading level altered as shown in Table 4. Thus, Transformers 5-6 and 7-8 have the highest loading levels in Cases 1 and 2, respectively. For both case studies, the transformers are operated within limit values.

Table 4: Transformer loading level

Transformer from bus to bus	Case-1 (%)	Case-2 (%)
4-7	28.43	11.15
4-9	15.3	8.95
5-6	41.92	38.30
7-8	15.91	54.48
7-9	27	47.81

The loading level of generators is given in Figure. 2. The loading level of Generator 2-4 increased in case of OPF (case-2). Generators 1 and 3 have the highest loading levels in Case-1 and Case-2, respectively. All generators are operated within limit values.

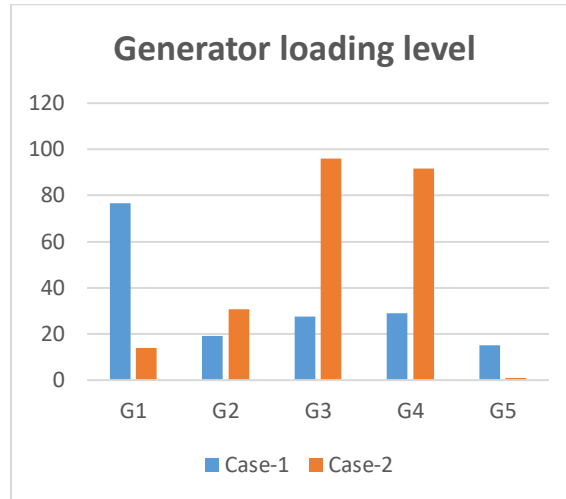

Figure 2: Generator loading level

The loading level of transmission lines is given in Table V. When OPF is applied to the power system, the active power of generators is changed, and it affects the transmission line loading level as shown in Table 5. The loading level of Line\_1-2, Line\_1-5, and Line\_2-3 are significantly decreased in case-2 thanks to OPF. So, the overloading of the transmission line can be prevented in case of load increase.

Table 5: Transmission line loading

Name	Case-1 %	Case-2 %
Line_10-11	3.87	5.05
Line_12-13	1.68	1.32
Line_13-14	5.59	3.17
Line_4_5	62.34	13.24
Line_6-11	7.58	5.16
Line_6-12	7.63	7.20
Line_6-13	17.8	15.52
Line_9-10	6.42	12.82
Line_9-14	9.58	14.18
Line_1-2	74.59	10.57
Line_1-5	71.38	27.79
Line_2-3	70.18	21.58
Line_2-4	53.76	30.82
Line_2-5	39.83	28.72
Line_3-4	23.86	9.9

Total active power, total reactive power, and total losses are given in Table VI for both cases. The total losses of the tested power system decreased from 13.39 to 2.31 MW thanks to OPF. The total produced active power of generators is reduced. Hence the power system can be operated economically.

Table 6: Comparison of results

Parameter	Case-1 (MW)	Case-2 (MW)
Total active power generation	272.39	261.31
Total load	259	259
Total losses	13.39	2.31

## 5. Conclusion

In this paper, a general overview of the OPF problem is presented. A standard mathematical formulation containing the formulation of the OPF problem as well as the objectives and constraints are represented. The interior point method has been successfully applied to the standard IEEE-14 bus test system to minimize total system losses. The AC power flow and OPF which uses the interior method optimization method are simulated using the optimum power flow/unit commitment tool of DIgSILENT/Powerfactory. The results are compared in terms of losses, loading of generator and transmission lines, and bus voltages. The total system losses are reduced from 13.39 MW to 2.31 MW. For future work, IPM can be implemented in real power systems thanks to simplicity to minimize total system losses. Also, metaheuristic methods, genetic algorithms, particle swarm optimization, and ant colony optimization can be applied to solve multi-objective optimization problems that include OPF and the economical operation of the power system.

## Acknowledgment

This work was supported by The Scientific and Technological Research Council of Turkey BIDEB-2214-A International Research Fellowship Programme for PhD Students.

## Contribution of Researchers

Conceptualization, Y.Y. and Ö.Ç.; methodology, Y.Y. and Ö.Ç.; software, Y.Y.; validation, Y.Y., Ö.Ç. and A.T; writing original draft preparation, Y.Y., Ö.Ç and A.T; writing review and editing, A.T. and K.Ç.B, supervision, A.T. and K.Ç.B; All authors have read and agreed to the published version of the manuscript.”

## Conflicts of Interest

We have no conflicts of interest to disclose.

## References

- [1] Malik, I. M., Srinivasan, D., 2010. Optimum power flow using flexible genetic algorithm model in practical power systems. In 2010 Conference Proceedings IPEC, Singapore, 1146-1151.
- [2] Singh, R. P., Mukherjee, V., Ghoshal, S. P., 2015. Optimal reactive power dispatch by particle swarm optimization with an aging leader and challengers. *Applied Soft Computing*, 29, 298-309.
- [3] P. S. Planning, 1972. *Optimal Power-Flow Solutions*, 6,1, 64–70.
- [4] J Momoh, J. A., Adapa, R., El-Hawary, M. E., 1999. A review of selected optimal power flow literature to 1993. I. Nonlinear and quadratic programming approaches. *IEEE transactions on power systems*, 14(1), 96-104.
- [5] Momoh, J. A., Adapa, R., El-Hawary, M. E., 1999. A review of selected optimal power flow literature to 1993 part ii: newton, linear programming and Interior Point Methods ,*IEEE Trans. Power System*, 14(1),105–111.
- [6] Capitanescu, F., Glavic, M., Ernst, D., Wehenkel, L., 2007. Interior-point based algorithms for the solution of optimal power flow problems. *Electric Power systems research*, 77(5-6), 508-517.
- [7] Capitanescu, F., Glavic, M., Wehenkel, L., 2005. An interior point method based optimal power flow, *Proc. ACOMEN Conference, Ghent, Belgium*,1–18.
- [8] Mohan, T. M., Nireekshana, T., 2019. A genetic algorithm for solving optimal power flow problem, 3rd International conference on Electronics, Communication and Aerospace Technology (ICECA), Coimbatore, India 1438–1440.
- [9] Wang, X., Yang, K., 2019. Economic load dispatch of renewable energy-based power systems with high penetration of large-scale hydropower station based on multi-agent glowworm swarm optimization, *Energy Strategy Reviews*, 26,100425.



- [10] J Giraldo, J. A., Montoya, O. D., Grisales-Noreña, L. F., Gil-González, W., Holguín, M., 2019. Optimal power flow solution in direct current grids using Sine-Cosine algorithm. In *Journal of Physics: Conference Series*,1403(1),012009).
- [11] Attia, A. F., El Sehiemy, R. A., Hasanien, H. M., 2018. Optimal power flow solution in power systems using a novel Sine-Cosine algorithm. *International Journal of Electrical Power & Energy Systems*, 99, 331-343.
- [12] C Sumpavakup, C., Srikun, I., Chusanapiputt, S., 2010. A solution to the optimal power flow using artificial bee colony algorithm, *International Conference on Power System Technology*, Zhejiang, China 1–5.
- [13] Le Dinh, L., Vo Ngoc, D., Vasant, P., 2013. Artificial bee colony algorithm for solving optimal power flow problem, *the scientific world journal*, 2013
- [14] Abaci, K., Yamacli, V., AKDAĞLI, A. 2016., Optimal power flow with SVC devices by using the artificial bee colony algorithm, *Turkish Journal of Electrical Engineering & Computer Sciences*, 24(1), 341-353.
- [15] Roy, R., & Jadhav, H. T., 2015. Optimal power flow solution of power system incorporating stochastic wind power using Gbest guided artificial bee colony algorithm, *International Journal of Electrical Power & Energy Systems*, 64, 562-578.
- [16] Zakian, P., Kaveh, A., 2018. Economic dispatch of power systems using an adaptive charged system search algorithm, *Applied Soft Computing*, 73, 607-622.
- [17] He S., Wen J. Y., Prempain E., Wu Q. H., Fitch J., Mann S., 2004. An improved particle swarm optimization for optimal power flow, *International Conference on Power System Technology*, Singapore, 1633–1637.
- [18] A Khan, A., Hizam, H., bin Abdul Wahab, N. I., Lutfi Othman, M., 2020. Optimal power flow using hybrid firefly and particle swarm optimization algorithm, *Plos one*, 15(8), 1–21.
- [19] Singh, R. P., Mukherjee, V., Ghoshal, S. P., 2015. Optimal reactive power dispatch by particle swarm optimization with an aging leader and challengers, *Applied Soft Computing*, 29, 298-309.
- [20] Patil, M., Vyas, D., Leheru, K., Jain, R., Mahajan, V., 2019. Optimal Power Flow Problem Using Particle Swarm Optimization Algorithm. *IEEE 5th International Conference for Convergence in Technology*, Bombay, India 11–15.
- [21] Federico M., 2011, *Power System Modelling and Scripting*.
- [22] DlgSILENT, 2020. *PowerFactory 2020 User Manual*, 1–1253.